

151226356 COMMUNICATIONS

Answers to Selected Exam Questions

by

Erol Seke

**Eskişehir Osmangazi University
Faculty of Engineering and Architecture
Department of Electrical and Electronics Engineering**

Last edited : 21.June.2018

Front Matter

This document is provided to the students of the course “151226356 COMMUNICATIONS” in order to help them to have an eye on past exam questions painlessly. The purpose, however, is not to create a solution manual for every communication problem faced throughout the course, rather give a clue on “possible future exam questions”. Some questions may seem to repeat or look very similar to others which indicate that I have no intention to keep track of or otherwise manage such a solution manual. Yet some other answers may not be exactly the same announced right after the exam. This is because I felt that additional explanations might be required to better understand the solution. If you have questions on solutions, you should raise it in the class when we are at the subject or at my office. My office hours are announced at the same internet site where you got this document.

1. 25.03.2003 1st midterm

Frequency spectrum of a signal $x(t)$ is given as

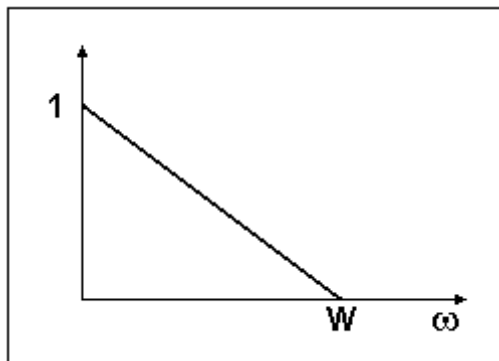

Find the spectrum of the signal $y(t) = x(t)[\sin(\omega_1 t) + \cos(\omega_2 t)]$

Solution

Using the modulation property of F.T. $FT\{x(t)\cos(\omega_0 t)\} = \frac{1}{2}X(\omega - \omega_0) + \frac{1}{2}X(\omega + \omega_0)$

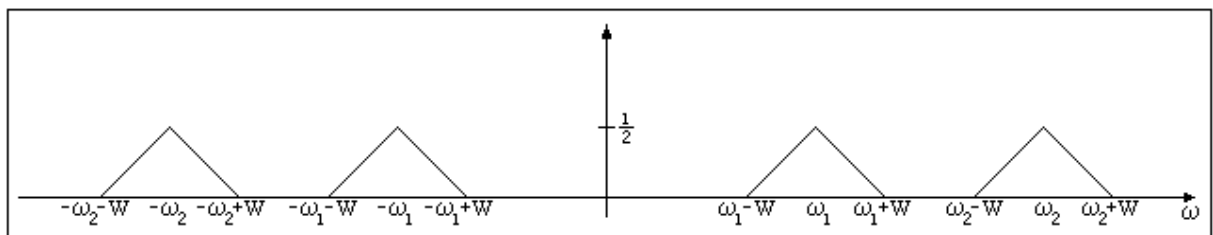

assuming $W \ll \omega_1 \ll \omega_2$

2. 25.03.2003 1st midterm

Determine the energy delivered to a 1Ω resistor from the source $v(t) = \frac{\sin(\omega t + a)}{a + \omega t}$ where a is a constant ranging from 0 to 2π .

Solution

Use the definition of the energy

$$E = \int_{-\infty}^{+\infty} |x(t)|^2 dt = \int_{-\infty}^{+\infty} \left| \frac{\sin(\omega t + a)}{a + \omega t} \right|^2 dt \quad (\text{use } \omega t + a = \pi x \text{ and } \omega dt = \pi dx \text{ here})$$

$$E = \frac{\pi}{\omega} \int_{-\infty}^{+\infty} \left| \frac{\sin(\pi x)}{\pi x} \right|^2 dx \quad (\text{and using Rayleigh}) \quad E = \frac{\pi}{\omega} \frac{1}{2\pi} \int_{-\infty}^{+\infty} |X(\omega)|^2 d\omega$$

$$E = \frac{1}{2\omega} \int_{-2\pi}^{+2\pi} d\omega = \frac{1}{2\omega} (\omega)_{-2\pi}^{+2\pi} = \frac{2\pi}{\omega}$$

The result is independent from the a as expected, since a is just a shift in time which has no effect on the total energy.

3. 25.03.2003 1st midterm

Find the power of the signal whose spectrum is given below.

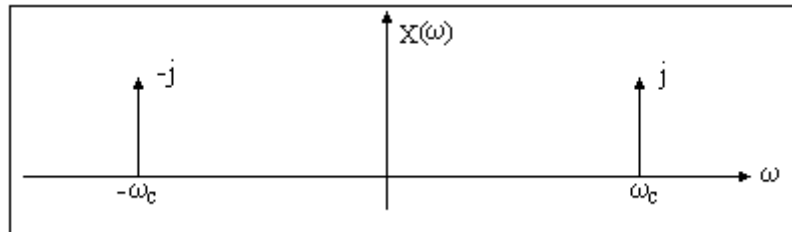

Solution

We know that $\sin(\omega_c t) \Leftrightarrow j\pi(\delta(\omega + \omega_c) - \delta(\omega - \omega_c))$

The F.T. of the given signal is $-j\delta(\omega + \omega_c) + j\delta(\omega - \omega_c)$ which is the F.T. of

$$-\frac{1}{\pi} \sin(\omega_c t) \quad (\text{consider linearity of F.T.})$$

The power of the periodic signal is

$$P = \frac{1}{T_c} \int_{\alpha}^{\alpha+T_c} |x(t)|^2 dt \quad \text{where } T_c = \frac{2\pi}{\omega_c}$$

$$P = \frac{1}{T_c} \int_0^{T_c} \left| -\frac{1}{\pi} \sin(\omega_c t) \right|^2 dt = \frac{1}{\pi^2 T_c} \int_0^{T_c} \sin^2(\omega_c t) dt = \frac{1}{2\pi^2}$$

4. 06.05.2003 2nd midterm

The transfer function of a baseband amplifier is given as $H(\omega) = ae^{-|\omega|}$ (shown below) where a is an adjustable constant. Two of such amplifiers are to be cascaded to have a gain of 10 and a noise figure of less than 11 dB at the zero frequency. Noise figure of a single stage is given as 10 dB. Calculate the minimum dc gain we should have at the first stage. Also calculate the noise-equivalent bandwidth of the entire system.

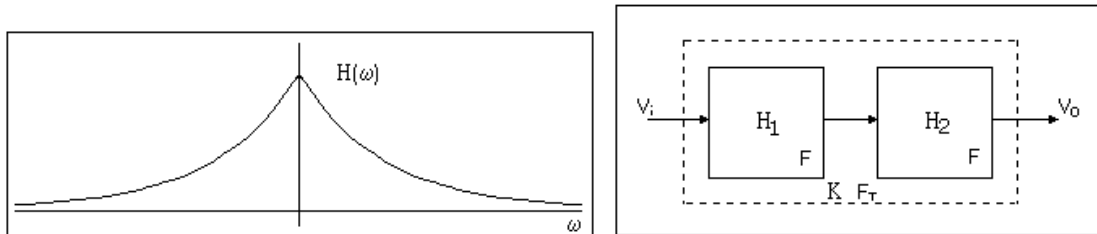

Solution

$$F = F_1 + \frac{F_1 - 1}{H_{1\max}^2} < 11, \quad 10 = 10 \log F \Rightarrow F = 10, \quad 10 + \frac{10 - 1}{H_{1\max}^2} < 11, \quad H_{1\max}^2 > 9, \quad H_{1\max} > 3$$

since a is the max gain then $a = H_{1\max}$ (minimum dc gain). The second stage can have $a > 10/3$

$$B_{neq} = \frac{\frac{1}{2\pi} \int_{-\infty}^{\infty} |H(\omega)|^2 d\omega}{2H_{\max}^2} = \frac{1}{4(a_1 a_2)^2 \pi} \int_{-\infty}^{\infty} |a_1 e^{-|\omega|} a_2 e^{-|\omega|}|^2 d\omega = \frac{1}{2\pi} \int_0^{\infty} e^{-4\omega} d\omega$$

$$B_{neq} = \frac{-1}{8\pi} e^{-4\omega} \Big|_0^{\infty} = \frac{1}{8\pi} \text{ [Hz]}$$

5. 06.05.2003 2nd midterm

Given the LTI system below, find $E\{v_o\}$ when pdf of V_i has a Gaussian shape with $m = 2$ and $\sigma^2 = 1$.

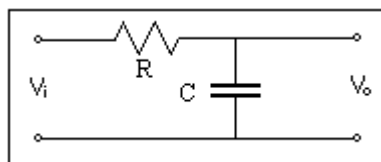

Solution

Output mean value depends only on the LTI system response at the zero frequency and input mean value;

$$E\{v_0\} = E\{v_i\}H(\omega)|_{\omega=0} = 2 \times 1 = 2$$

6. 06.05.2003 2nd midterm

A transmission channel carries differential binary (baseband) signal as shown in figure below. Signal is sampled at the midpoints of the bit-durations. If the sample value is positive then the binary value is assumed to be 1 otherwise it is assumed to be 0. Find the probability of having an incorrect reading/decision in the presence of additive noise whose pdf is also given in the figure on the right.

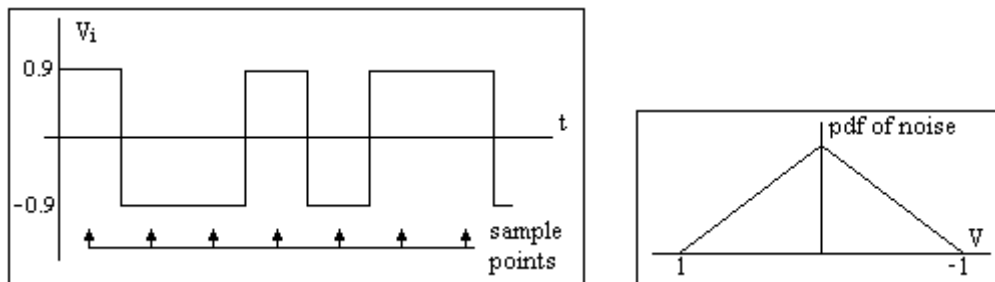

Solution

Since the system is symmetric (ie. $P(0)|_{v_i=1} = P(1)|_{v_i=-1}$) it is satisfactory to calculate only $P(0)|_{v_i=1}$ which is the area shown in the figure below.

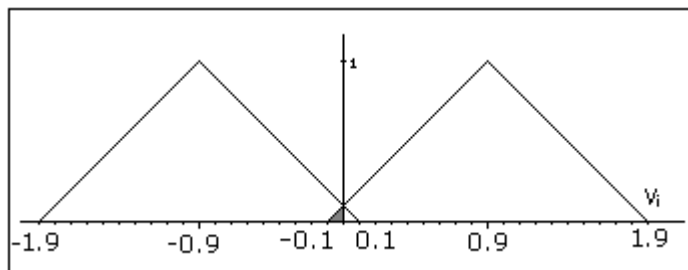

$$P_e = \int_{-0.1}^0 (v_i + 0.1) dv_i = \frac{v_i^2}{2} + 0.1v_i \Big|_{-0.1}^0 = -\frac{0.01}{2} + 0.01 = 0.005$$

7. 19.06.2003 final exam

The output of a binary source is transmitted over a channel under zero mean additive white Gaussian noise with the standard deviation of 1. At the source, $+V_0$ is sent for binary-1 and $-V_0$ is sent for binary-0. At the receiver it is assumed that a 1 is received if the input reading is positive and a 0 otherwise. Find the minimum value of V_0 for the incorrect channel reading probability to be less than 0.0001.

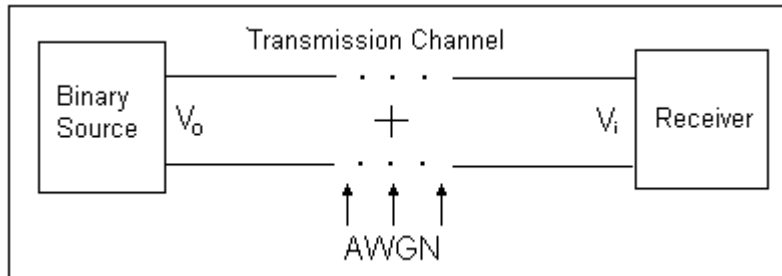

Solution

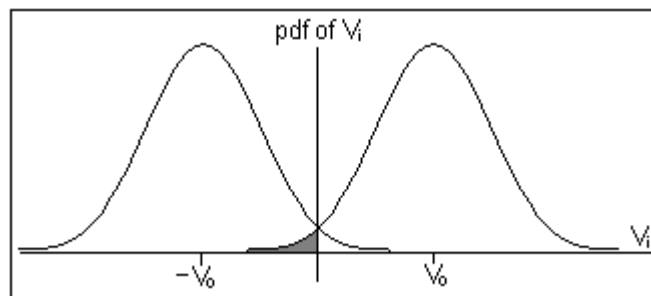

The probability of "zero" received when "one" is sent is the shaded area shown in the figure. Since the system is symmetric, $P(0|1)=P(1|0)$ (the curves in the figure are $N(m=\pm V_0, \sigma=1)$)

$$I = \int_{-\infty}^0 \frac{1}{\sqrt{2\pi}\sigma} e^{-\frac{(x-m)^2}{2\sigma^2}} dx \quad \text{where } m=V_0 \text{ and } \sigma=1. \text{ A little tweaking, we get}$$

$$I = \int_{-\infty}^{-V_0} \frac{1}{\sqrt{2\pi}} e^{-\frac{t^2}{2}} dt. \text{ This last integral is } \Phi(t). \text{ } Q(t)=1-\Phi(t) \text{ gives } P(t>V_0).$$

$Q = \int_{V_0}^{\infty} \frac{1}{\sqrt{2\pi}} e^{-\frac{t^2}{2}} dt$ which is well tabulated. Since I (also Q) is given as 0.0001, using the table on the back sheet we find that this value can be approximately obtained with $V_0 \cong 3.7$

8. 19.06.2003 final exam

A white Gaussian process $N(2,2)$ with $N_0/2$ [W/Hz] flat psd is applied to the input of the circuit given. Find the psd of the output. Also calculate the mean of the output. Assume $R=C=1$

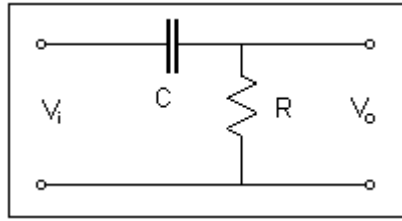

Solution

$$H(\omega) = \frac{j\omega RC}{1 + j\omega RC} \text{ and } |H(\omega)|^2 = \frac{\omega^2 R^2 C^2}{1 + \omega^2 R^2 C^2}$$

$$S_o(\omega) = S_i(\omega) |H(\omega)|^2 = \frac{2\pi N_0}{2} \frac{\omega^2 R^2 C^2}{1 + \omega^2 R^2 C^2} = \frac{\pi N_0 \omega^2}{1 + \omega^2}$$

The output mean value depends only on the input mean value and $H(\omega)$ at $\omega=0$ (DC). That is $m_o = m_i H(0) = 2 \times 0 = 0$. (We could intuitively reach that result by looking at the circuit and see the fact that it does not let the 0 frequency components pass because of the capacitor. Immediate result of this is that for all signals (satisfying Dirichlet conditions) the output should swing about the zero, meaning the mean of the output is zero.)

9. 19.06.2003 final exam

Find Huffman code for each symbol given in table below. Also calculate the average bit-length of the symbols and compare with the entropy.

Solution

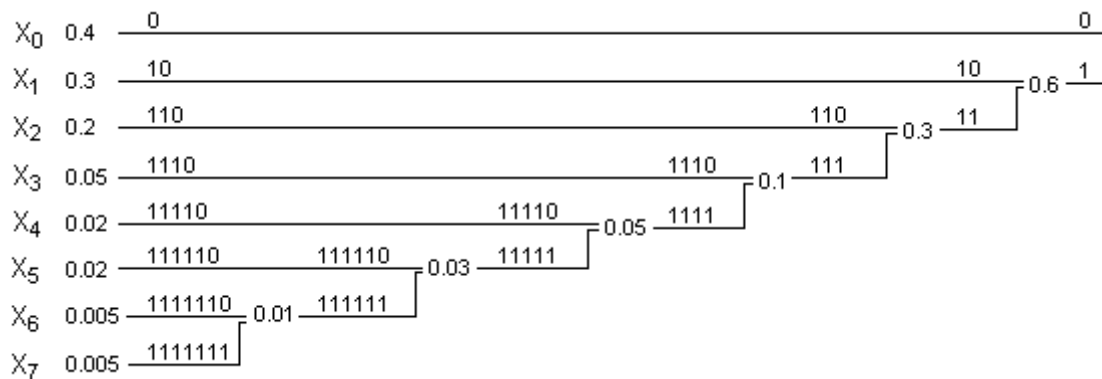

$$L_{avg} = \sum_i P(X_i) L_i = 0.4 \times 1 + 0.3 \times 2 + 0.2 \times 3 + 0.05 \times 4 + 0.02 \times 5 + 0.02 \times 6 + 0.005 \times 7 + 0.005 \times 7$$

$$L_{avg} = 2.09 \text{ [bits/symbol]}$$

$$H(X) = -\sum_i P(X_i) \log_2(P(X_i))$$

$$H(X) = -(0.4 \times \log(0.4) + 0.3 \times \log(0.3) + 0.2 \times \log(0.2) + 0.05 \times \log(0.05) + 0.02 \times \log(0.02) + 0.02 \times \log(0.02) + 0.005 \times \log(0.005) + 0.005 \times \log(0.005))$$

$$H(X) = 2,03254 \text{ [bits]}$$

Huffman code we have found has the average symbol length of 2.09. This is a little higher than the possible minimum average symbol length, which is the entropy itself. This means we are very close to an ideal code.

10. 06.04.2004 first midterm

A binary channel with $P(1|1) = 0.8$ and $P(0|0) = 0.9$ is given. The channel is fed with 5-bit characters/symbols from a pool of 32 characters/symbols with equal probability. Calculate the maximum and minimum values for the probability of incorrect reception of a 5-bit character.

Solution

Since all characters are of the same probability, the probabilities of encountering 0 and 1 are equal. We shall have the minimum probability of error when all 5 bits are 0.

Thus $P(S_o = 00000 | S_i = 00000) = 0.9 \times 0.9 \times 0.9 \times 0.9 \times 0.9 = 0.9^5 \cong 0.59$ (probability of correct reception when all the input bits are 0.) Here S_i and S_o indicates the bit streams representing input and output characters/symbols respectively. Therefore $P_e(S_o \neq 00000 | S_i = 00000) \cong 0.41$ (probability of incorrect reception)

Similarly $P(S_o = 11111 | S_i = 11111) = 0.8 \times 0.8 \times 0.8 \times 0.8 \times 0.8 = 0.8^5 \cong 0.33$ is the probability of receiving 11111 when 11111 is sent. The complement of this, $P_e(S_o \neq 11111 | S_i = 11111) \cong 0.67$ is the probability of incorrect reception when 11111 is sent, and this is the maximum of the error probability.

11. 06.04.2004 first midterm

Show that, in general, the energy of the signal $f(t) = f_1(t) + f_2(t)$ is not $E_1 + E_2$ where E_1 and E_2 are the energies of $f_1(t)$ and $f_2(t)$ respectively. Determine also the respective conditions under which $E_{tot} = E_1 + E_2$ and $E_1 + E_2 = 0$.

Solution

$$E_{tot} = \int_{-\infty}^{\infty} |f_1(t) + f_2(t)|^2 dt = \int_{-\infty}^{\infty} |f_1(t)|^2 dt + \int_{-\infty}^{\infty} |f_2(t)|^2 dt + 2 \int_{-\infty}^{\infty} |f_1(t)f_2(t)| dt$$

$$E_{tot} = E_1 + E_2 + E_x \neq E_1 + E_2 \text{ (unless } E_x = 0)$$

In order for $E_{tot} = E_1 + E_2$ the $\int_{-\infty}^{\infty} |f_1(t)f_2(t)|dt$ term must be zero which requires that either one or both of the signals be zero for any given t.

As seen in the integral definition, energy can not be negative. Therefore both E_1 and E_2 must be individually zero to have $E_1 + E_2 = 0$. This requires that both $f_1(t)$ and $f_2(t)$ must be zero.

12. 06.04.2004 first midterm

Write down the advantages and disadvantages of conventional-AM, DSB-SC-AM, SSB-AM and VSB-AM compared to other each other.

Solution

- Conventional-AM wastes more power than any other AM types.
- Conventional-AM signals are easier to demodulate minimally requiring just a half-wave rectifier and an integrator (a diode and RC-circuit)
- Suppressed carrier types require a synchronous demodulator. This means that a sinusoidal identical to the carrier at the transmitter must be generated at the receiver, requiring PLLs = means additional cost.
- VSB has lesser filter quality criteria, compared to SSB types, which makes it cheaper on that account, however, envelope detection is still not possible. So synchronous detection is employed, but this time we have some carrier power to get synchronized with.

(For the sake of drawing attention to obvious differences we have omitted the comparisons related to noise/distortion/fading issues where more detailed analysis and understanding need to be shown.)

13. 11.05.2004 2nd midterm

A binary transmission line is under the additive stationary noise whose pdf is given below along with a sample input waveform. The receiver uses a 2.5 V level for decision after sampling its input. Calculate the probability of error at the next sample when the input probabilities are given as $P(V_s=0 \text{ V})=0.6$ and $P(V_s=5 \text{ V})=0.4$.

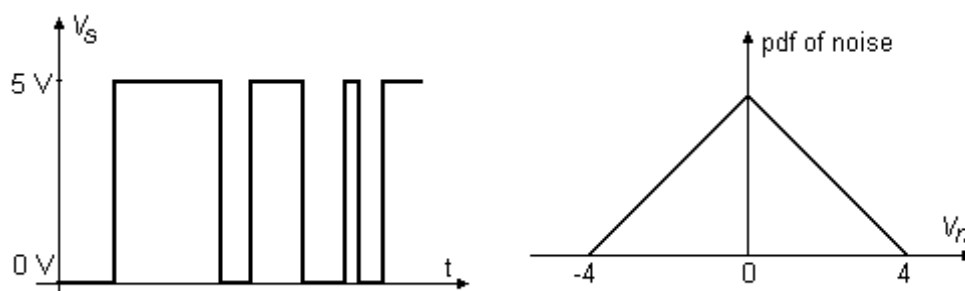

Solution

The errors when $V_s=0$ and $V_s=5$ V are given as the shaded areas in figures

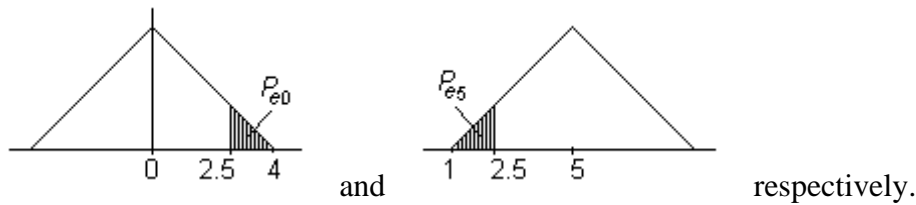

$$P_{e0} = \int_{2.5}^4 (0.25 - \frac{0.25}{4}x) dx \cong 0.07 \text{ and } P_{e5} \cong 0.07 \text{ (symmetric)}$$

$$\text{So the total (average) error is } P_e = P_0P_{e0} + P_5P_{e5} \cong 0.07$$

14. 11.05.2004 2nd midterm

The input to a linear system with $|H(\omega)| = \begin{cases} |2\pi|, & |\omega| < 3000 \\ 0, & \text{otherwise} \end{cases}$ is a white Gaussian noise

with $S_n(\omega) = \frac{N_0}{2}$. Find out the “Noise Equivalent Bandwidth” and output power spectral density.

Solution

Since the spectrum is flat within the range $|\omega| < 3000$ B_{neq} is equivalent to the actual bandwidth of $H(\omega)$ which is 3000 rd/sn.

$$S_{on}(\omega) = S_n(\omega)|H(\omega)|^2 = \frac{N_0}{2}(2\pi)^2 = 2N_0\pi^2 \quad |\omega| < 3000 \text{ and } 0 \text{ elsewhere.}$$

15. 11.05.2004 2nd midterm

Find the Huffman or Shannon-Fano code for the source with probabilities $v=\{0.3, 0.2, 0.18, 0.1, 0.1, 0.07, 0.05\}$. Calculate the average code length and average information per source output.

Solution

Shannon-Fano and Huffman trees are constructed as given below

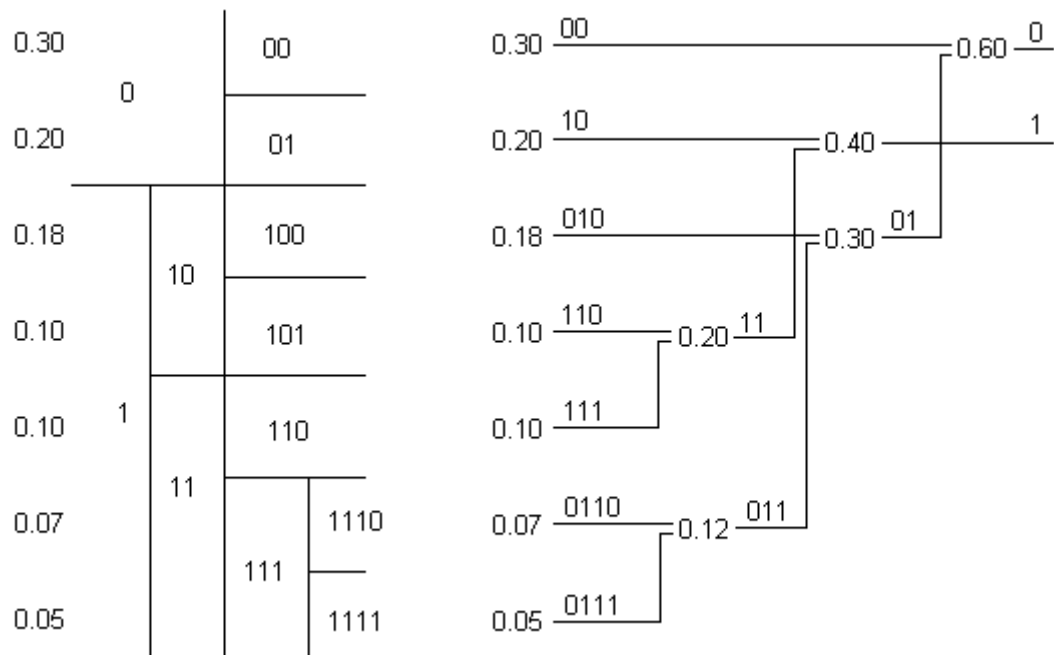

The corresponding code alphabets are then
 $S = \{00, 01, 100, 101, 110, 1110, 1111\}$ for Shannon-Fano solution, and
 $H = \{00, 10, 010, 110, 111, 0110, 0111\}$ for Huffman solution.

Noticing that binary symbol lengths for two cases are the same,

$$L_{avg} = \sum_{i=1}^7 P_i L_i = 0.3 \times 2 + 0.2 \times 2 + 0.18 \times 3 + 0.1 \times 3 + 0.1 \times 3 + 0.07 \times 4 + 0.05 \times 4 = 2.62 \text{ bits/symbol}$$

Average information per source symbol equals the entropy, so

$$H(v) = -\sum_{i=1}^7 P_i \log_2(P_i) \cong 2.58 \text{ bits/symbol}$$

16. 23.09.2003 make-up

Find the energy of the signal whose F.T. is given in figure below

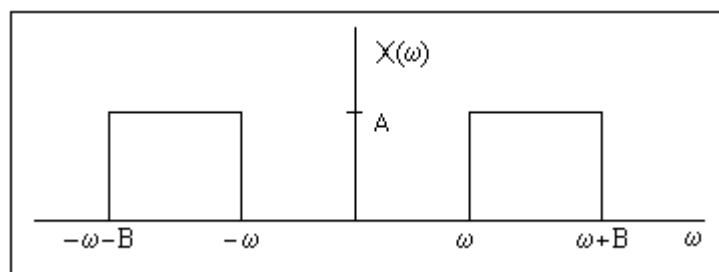

Solution

$$E = \frac{1}{2\pi} \int_{-\infty}^{\infty} |X(\omega)|^2 d\omega = \frac{2}{2\pi} \int_{\omega}^{\omega+B} |A|^2 d\omega = \frac{A^2}{\pi} \omega \Big|_{\omega}^{\omega+B} = \frac{A^2 B}{\pi}$$



17. 23.09.2003 make-up

Guess/make-up a pdf for a binary signaling schema in which the probability of receiving 0-zero when the signal actually sent is 1-one and receiving 1 when the signal actually sent is 0 are 0.01.

Solution

Let us assume that $P(0)=P(1)$ and 0 is represented with a positive voltage level X while 1 is represented by $-X$. Let us also assume that the pdf of the signal at both levels has triangular shape as shown with the top of the triangle is at 1. (corrected)

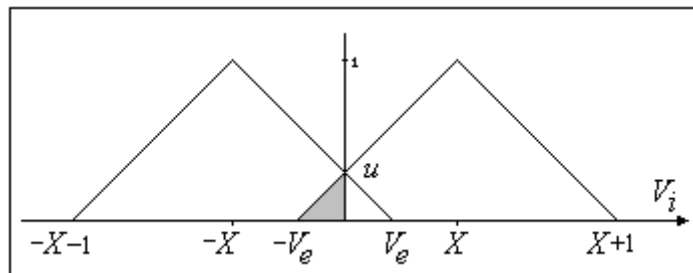

If we assume that receiving a negative voltage means "zero" and otherwise it means "1", the shaded area must be 0.01. Using the similarity of triangles

$$\frac{1}{X + V_e} = \frac{u}{V_e} \quad \text{and} \quad \frac{uV_e}{2} = 0.01, \quad \text{and also} \quad X + V_e = 1 \quad (\text{total area is 1})$$

$V_e = u$ and $V_e^2 = 0.02$. So, $V_e \cong 0.14142$ and $X = 1 - V_e = 1 - 0.14142 \cong 0.85858$

That is; if we create/design a system which represents "0" and "1" binary numbers using levels $-X$ and X with triangularly shaped pdfs given in the figure where V_e and X as calculated we shall have a probability of making an erroneous reading of 0.01.

18. 23.09.2003 make-up

Find the Huffman code for the ensemble whose probabilities given as {0.3, 0.25, 0.2, 0.05, 0.1, 0.05, 0.03, 0.02}

Solution

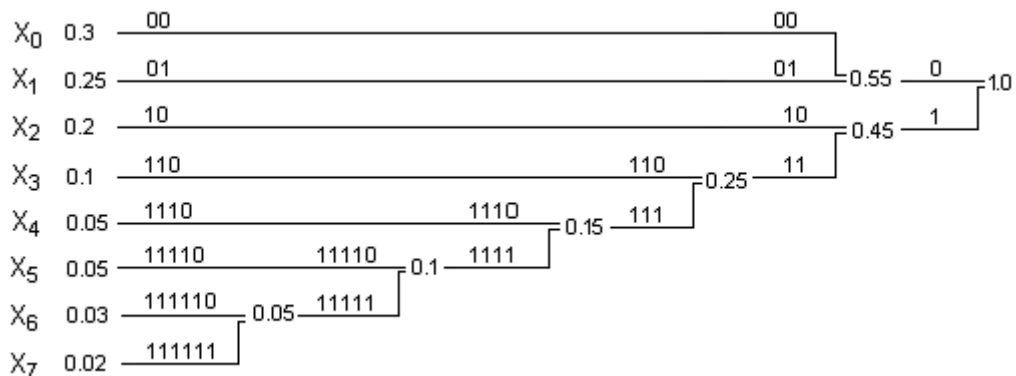

19. 31.05.2004 2nd quiz

A binary symmetric channel is under additive white Gaussian noise with mean 0 V and variance 1. At the input $-V_0$ and V_0 are used for binary symbols 0 and 1 respectively. Determine the minimum value for V_0 to achieve probability of channel reading error at the channel output to be 0.01.

Solution

Searching the $Q(x)$ column of the Q table for the 0.01 value and determining the corresponding x value we find that

$$V_0 = 2.3 \text{ V}$$

approximately satisfies the error constraint.

20. 01.06.2004 2nd quiz

Return-To-Zero (RZ) signaling systems can be considered as ternary. A sample waveform is given below. Under zero mean AWG noise with $\sigma^2 = 1$, calculate the probability of channel reading error at the output of the channel when $V_1 = 2$, $V_0 = 0$ and $V_2 = -2$ V. Error can be formulated by $P(V_j : j \neq i | V_i)$; prob. of something else is received when V_i is sent. Assume that $P(1_b) = 0.5$ and threshold voltages $V_t = \pm 1$ V.

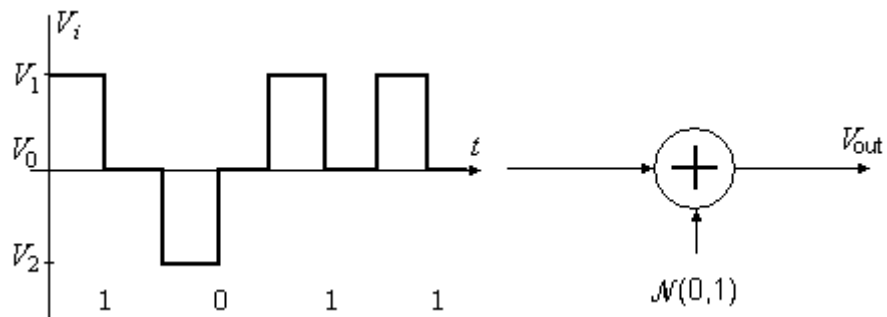

Solution

The figure below displays three Gaussian distributions together. Figure also shows, as example, the area representing the error when V_2 is sent and the area representing half of the error when V_0 is sent.

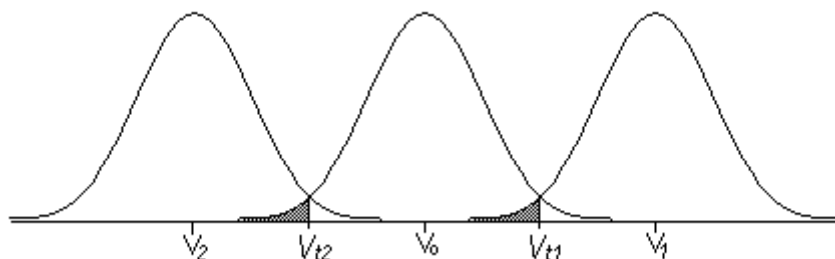

Using the figure;

$$P(e | -2) = P(V_{out} > -1 | V_i = -2) = Q(1) \cong 0.1587$$

$$P(e | 2) = P(V_{out} < 1 | V_i = 2) = Q(1) \cong 0.1587$$

$$P(e | 0) = P(V_{out} < -1 | V_i = 0) + P(V_{out} > 1 | V_i = 0) = 2xQ(1) \cong 2x0.1587$$

$$P(V_i = -2) = \frac{1}{2}P(1_b) = 0.25$$

$$P(V_i = 2) = \frac{1}{2}P(0_b) = 0.25$$

$$P(V_i = 0) = \frac{1}{2}P(0_b) + \frac{1}{2}P(1_b) = 0.5$$

$$P_e = P(e | V_i = -2)P(V_i = -2) + P(e | V_i = 2)P(V_i = 2) + P(e | V_i = 0)P(V_i = 0)$$

$$P_e = \sum_{i=0}^2 P(V_i)P(e | V_i)$$

$$P_e = 0.25x0.1587 + 0.25x0.1587 + 0.5x2x0.1587 = 0.238$$

21. 08.06.2004 final exam

Derive mathematical basis and suggest a synchronous demodulation method to demodulate conventional AM signal given as $y(t) = A(1 + a_m x_n(t)) \cos(\omega t + \Phi)$ where a_m is the modulation index, A is an arbitrary constant and Φ is an arbitrary constant phase-shift. Regenerated carrier signal at the receiver is given as $s(t) = B \cos(\omega t + \Theta)$ where B is an arbitrary constant and Θ is an arbitrary constant phase-shift.

Solution

$$y(t)s(t) = A(1 + a_m x_n(t)) \cos(\omega t + \Phi) B \cos(\omega t + \Theta), \text{ using trigonometric identities}$$

$$y(t)s(t) = K_1(1 + a_m x_n(t)) + K_2(1 + a_m x_n(t)) \cos(2\omega t + \Phi + \Theta)$$

$$y(t)s(t) = K_1 + K_1 a_m x_n(t) + Z_{HF}(t)$$

where first term is DC value, second term is the baseband message signal multiplied by a constant and the third term is high frequency components located around 2ω frequency.

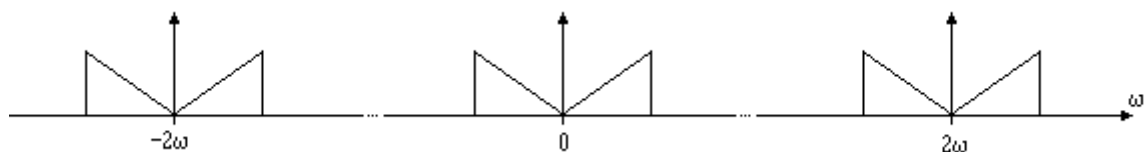

Feeding this signal to a low pass filter and allowing only the baseband message signal to pass we would recover the message signal.

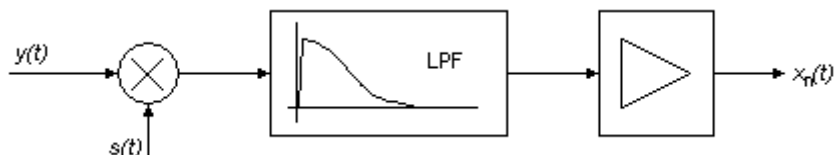

Notice that DC part is excluded - which can be blocked simply by the use of a capacitor on the signal path.

22. 08.06.2004 final exam

A binary channel is under AWGN with $\sigma^2 = 4$ and zero mean. Calculate the minimum difference between the voltage levels representing 0 and 1 in order to achieve bit error rate of 1×10^{-8} . Assume that the detection threshold is the midpoint of these two levels.

Solution

$$pdf_{noise} = \frac{1}{\sqrt{2\pi}\sigma} e^{-\frac{x^2}{2\sigma^2}} = \frac{1}{\sqrt{8\pi}} e^{-\frac{x^2}{8}}$$

Let us assume that voltage levels are V_0 and V_1 .

$$V_t = \frac{V_1 - V_0}{2} \text{ and the probability of erroneous reading shall be } P(1|0) = P(V_i > V_t | 0)$$

which is the same as in the case where $V_0 = 0$.

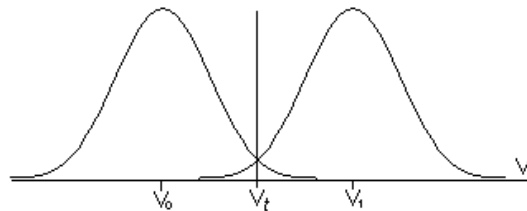

$$P_e = \int_{V_t}^{\infty} \frac{1}{\sqrt{8\pi}} e^{-\frac{V_i^2}{8}} dV_i = Q\left(\frac{V_t}{2}\right) = Q(x).$$

For this to be less than 1×10^{-5} we look up in $Q(x)$ table and find $x \cong 5.6$.

$$\text{So } V_t = 2x5.6 = 11.2V \Rightarrow V_1 - V_0 \geq 22.4V$$

23. 08.06.2004 final exam

Input to the filter shown below is the sum of flat Gaussian noise given as

$$S_n(\omega) = \begin{cases} \frac{N_0}{2}, & |\omega| < 20\pi \\ 0, & \text{otherwise} \end{cases} \text{ and flat spectral signal given as } S_s = \begin{cases} 1, & |\omega| < 10\pi \\ 0, & \text{otherwise} \end{cases}.$$

Calculate the input and output SNR and SNR improvement resulted by the use of the filter.

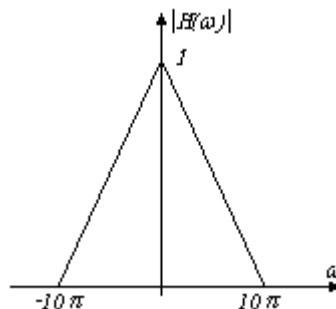

Solution

$$\text{Input noise power : } P_{ni} = \frac{1}{2\pi} \frac{N_0}{2} 40\pi = 10N_0$$

$$\text{Input signal power : } P_{si} = \frac{1}{2\pi} 20\pi = 10$$

$$SNR_i = \frac{10}{10N_0} = \frac{1}{N_0}$$

$$\text{Output noise power : } P_{no} = \frac{N_0}{2\pi} \int_0^{10\pi} \left| 1 - \frac{\omega}{10\pi} \right|^2 d\omega = \frac{10}{6} N_0$$

$$\text{Output signal power : } P_{so} = \frac{1}{\pi} \int_0^{10\pi} \left| 1 - \frac{\omega}{10\pi} \right|^2 d\omega = \frac{20}{6}$$

$$SNR_o = \frac{20/6}{10/6N_0} = \frac{2}{N_0}$$

$$\text{SNR improvement : } \frac{SNR_o}{SNR_i} = 2$$

24. 07.04.2005 1st midterm

Estimate, without trigonometric calculations, the Fourier spectrum of the SSB-AM (LSB with unsuppressed carrier) modulated signal for the baseband signal

$$x(t) = \sin(\omega_1 t) - 2 \cos(\omega_2 t) + 4 \quad \text{and} \quad c(t) = \cos(\omega_c t) \quad (\omega_1 < \omega_2 \ll \omega_c)$$

and draw the magnitude of the spectrum.

Solution

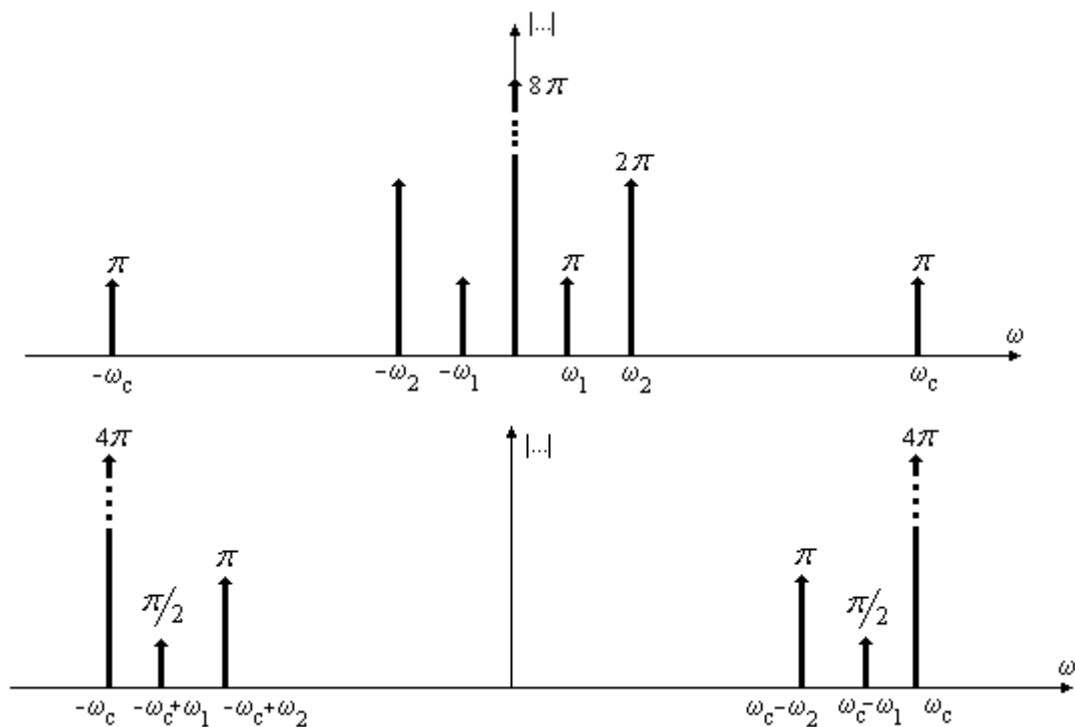

25. 07.04.2005 1st midterm

Find the power and energy of the waveform $y(t) = |\cos(8\pi t)|$

Solution

$$P = \frac{1}{T} \int_a^{a+T} |x(t)|^2 dt$$

$$P = \frac{1}{\frac{1}{8}} \int_{-1/16}^{1/16} \cos^2(8\pi t) dt$$

$$P = 8 \left[\frac{t}{2} + \frac{\sin(16\pi t)}{32\pi} \right]_{-1/16}^{1/16} = \frac{1}{2}$$

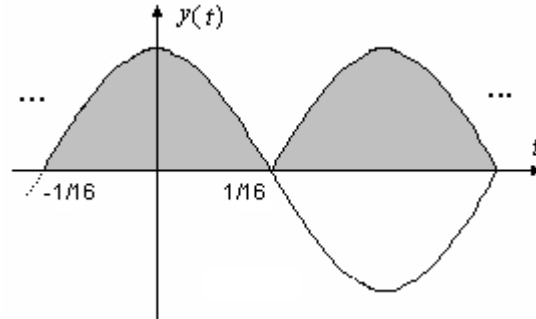

Since $\frac{1}{2} < \infty$, it is a power signal. Therefore it is not an energy signal. So, $E = \infty$.

26. 07.04.2005 1st midterm

Prove the linearity of the Fourier transform

Solution

$X(\omega) = \int_{-\infty}^{\infty} x(t)e^{-j\omega t} dt$, Let $x(t) = A_1x_1(t) + A_2x_2(t)$. The F.T. of it shall be

$$X(\omega) = \int_{-\infty}^{\infty} (A_1x_1(t) + A_2x_2(t))e^{-j\omega t} dt = A_1 \int_{-\infty}^{\infty} x_1(t)e^{-j\omega t} dt + A_2 \int_{-\infty}^{\infty} x_2(t)e^{-j\omega t} dt$$

$$X(\omega) = A_1X_1(\omega) + A_2X_2(\omega)$$

and finally

$$\mathfrak{F}\{A_1x_1(t) + A_2x_2(t)\} = A_1\mathfrak{F}\{x_1(t)\} + A_2\mathfrak{F}\{x_2(t)\} \text{ so F.T. is linear.}$$

27. 07.04.2005 1st midterm

The two signals shown below DSB modulate a carrier signal $c(t) = A\cos(\omega_0 t)$. Precisely plot the resulting modulated signals as a function of time and comment on their differences and similarities.

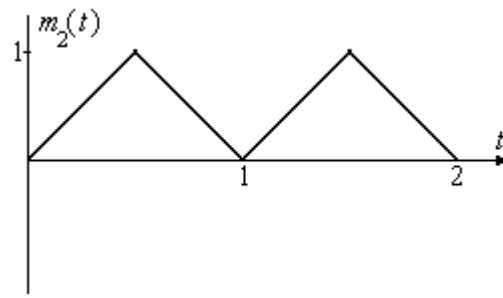
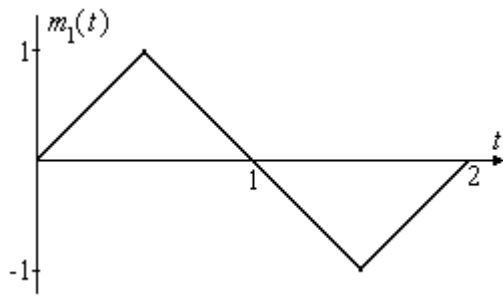

Solution

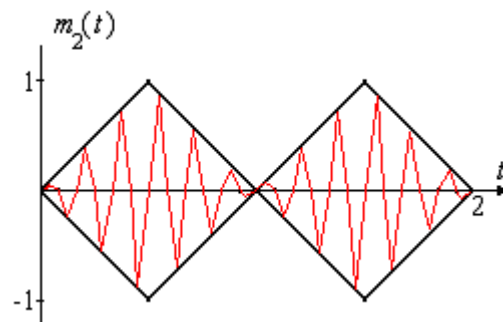
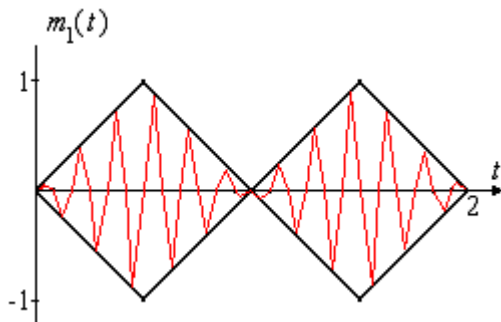

The envelopes are identical, however there is a 180 degrees phase shift in the first one because of which synchronous demodulator is required to demodulate it. The second one never goes negative; therefore such a phase shift does not occur, meaning that, envelope detection is satisfactory (using a rectifier and RC circuitry for example).

28. 18.05.2005 2nd midterm

In a binary transmission system 0 and 1 are represented by 0 V and 5V respectively. The probabilities of transmitting these values are given as

$$P(0 \text{ V}) = 0.7 \text{ and } P(5 \text{ V}) = 0.3$$

The channel is under additive noise whose pdf is given as (vs Volts)

$$f_x(x) = \begin{cases} \frac{1}{9}x + \frac{1}{3} & , \quad -3 < x < 0 \\ -\frac{1}{9}x + \frac{1}{3} & , \quad 0 \leq x < 3 \\ 0 & , \quad \textit{otherwise} \end{cases}$$

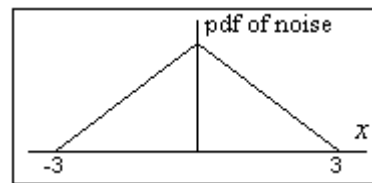

Calculate the threshold voltage for decision at the receiver for minimum probability of error, P_e . Determine P_e for the threshold you have just found.

Solution

A useful result of total probability theorem is that $P_e = P(0)P(1 | 0) + P(1)P(0 | 1)$, that is the weighted sum of errors created in both cases of sending 0 and 1 determines the average detection error. The weights are, of course, the probabilities of sending 0 and 1. So,

$$P_e = P(0) \int_{V_t}^3 f_X(x) dx + P(1) \int_2^{V_t} f_X(x-5) dx,$$

where x is the input voltage, the first integral is the area representing the probability of deciding 1 is received when actually 0 was sent, the second integral is the area representing the probability of deciding 0 is received when actually 1 was sent and V_t is the threshold voltage to be determined. Hence,

$$P_e = 0.7 \int_{V_t}^3 \left(-\frac{1}{9}x + \frac{1}{3}\right) dx + 0.3 \int_2^{V_t} \left(\frac{1}{9}(x-5) + \frac{1}{3}\right) dx$$

$$P_e = 0.7 \left(\frac{1}{18}V_t^2 - \frac{1}{3}V_t + \frac{1}{2}\right) + 0.3 \left(\frac{1}{18}V_t^2 - \frac{2}{9}V_t + \frac{2}{9}\right) = \frac{1}{18}V_t^2 - \frac{3}{10}V_t + \frac{75}{180}$$

In order to find V_t that minimizes this function we find the point which makes its first derivative zero.

$$\frac{\partial P_e}{\partial V_t} = \frac{1}{9}V_t - \frac{3}{10} = 0, \text{ and from here we find that } V_t = 2.7 \text{ Volts.}$$

The probability of making incorrect decision when the threshold is set to this value is, then

$$P_e = \frac{1}{18}(2.7)^2 - \frac{3}{10}(2.7) + \frac{75}{180} \cong 0.0117$$

29. 18.05.2005 2nd midterm

The noise at the input of the LTI system shown in the figure is given to be *Additive-White-Gaussian* with spectral density of $\frac{N_0}{2}$. Determine the output noise power.

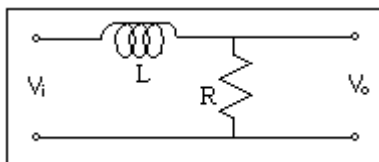

Solution

$$\frac{V_o}{V_i} = \frac{R}{R + j\omega L} = \frac{1}{1 + j\omega \frac{L}{R}} = H(\omega)$$

We know that $S_o(\omega) = S_i(\omega)|H(\omega)|^2$ and $P_o = \frac{1}{2\pi} \int_{-\infty}^{\infty} S_o(\omega) d\omega$ (definition of psd)

Applying,

$$P_o = \frac{1}{2\pi} \int_{-\infty}^{\infty} S_i(\omega) |H(\omega)|^2 d\omega = \frac{1}{2\pi} \int_{-\infty}^{\infty} \frac{N_0}{2} \frac{d\omega}{1 + \omega^2 L^2 / R^2}$$

$$P_o = \frac{N_0 R}{4\pi L} \tan^{-1} \left(\frac{L\omega}{R} \right) \Big|_{-\infty}^{\infty} = \frac{N_0 R}{4L} \text{ [Watts]} \text{ (assuming that } N_0/2 \text{ is given in Watts/Hz)}$$

30. 18.05.2005 2nd midterm

Effective Noise Temperature, T_e , can be defined as the noisiness of a two port. In an RF-amplifier laboratory of a manufacturer the following experiment is done. A signal is added some noise and fed through the input of the amplifier. Input and output SNRs of an amplifier are measured to be 20 dB and 10 dB respectively. Determine the effective noise temperature of the amplifier under inspection at room temperature (290°K).

Solution

Input and output SNRs are related with $\left(\frac{S}{N}\right)_o = \frac{1}{1 + \frac{T_e}{T}} \left(\frac{S}{N}\right)_i$

Also $10 \log SNR_i = 20 \text{ dB} \Rightarrow SNR_i = 100$, and $10 \log SNR_o = 10 \text{ dB} \Rightarrow SNR_o = 10$

So,

$$10 = \frac{100}{1 + \frac{T_e}{T}} \Rightarrow 1 = \frac{10}{1 + \frac{T_e}{290}} \Rightarrow T_e = 2610 \text{ °K}$$

31. 20.06.2005 final exam

A binary channel is under additive noise with zero mean Gaussian pdf. The variance of noise is given as 1 V^2 . The input to the channel is 0 or 5 V representing binary digits of 0 and 1 respectively. However, the probabilities of sending 0 and 1 are not the same. The probability of sending 0 is 0.6 whereas the probability of transmitting 1 is 0.4. The decision threshold, at the receiver, is set to 2.4 V. Calculate the probability of incorrect decision at the receiver.

Solution

$$P_e = P(0)P(1|0) + P(1)P(0|1)$$

$$P_e = P(v_i = 0V)P(v_o > 2.4V | v_i = 0V) + P(v_i = 5V)P(v_o < 2.4V | v_i = 5V)$$

$$P(v_i = 0V)P(v_o > 2.4V | v_i = 0V) = \frac{1}{\sqrt{2\pi}\sigma} \int_{2.4}^{\infty} e^{-\frac{(x-0)^2}{2\sigma^2}} dx$$

$$P(v_i = 5V)P(v_o < 2.4V | v_i = 5V) = \frac{1}{\sqrt{2\pi}\sigma} \int_{-\infty}^{2.4} e^{-\frac{(x-5)^2}{2\sigma^2}} dx \text{ (and } \sigma \text{ is given as } 1)$$

$$\text{Since } \frac{1}{\sqrt{2\pi}} \int_{-\infty}^{2.4} e^{-\frac{(x-5)^2}{2}} dx = \frac{1}{\sqrt{2\pi}} \int_{2.6}^{\infty} e^{-\frac{x^2}{2}} dx \text{ and } Q(X) = \frac{1}{\sqrt{2\pi}} \int_x^{\infty} e^{-\frac{x^2}{2}} dx$$

Looking up $Q(x)$ tables for the required values

$$P_e = 0.6xQ(2.4) + 0.4xQ(2.6) = 0.6x0.008198 + 0.4x0.004661 = 0.0067832$$

32. 20.06.2005 final exam

A pre-emphasis / de-emphasis system shown in the figure has de-emphasis filter characteristic given as $D(\omega) = \frac{1}{1 + j\omega}$, matching the pre-emphasis $P(\omega)$. The transmission channel is under additive white noise with flat power spectral density of 1 [W/rad/s]. Calculate the output noise power

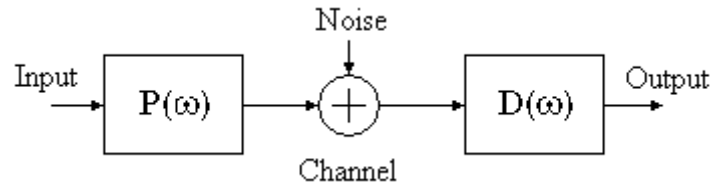

Solution

The question is not specifically a pre-emphasis / de-emphasis filter system problem. We do not need to know anything about the pre-emphasis filter except that its output has no noise, but the noise is added to the signal in the channel. In that case, the problem is simply a LTI system output with white noise at its input. Input and output power spectral densities are related by

$$S_{Do}(\omega) = S_{Di}(\omega) |D(\omega)|^2$$

$$\text{where } |D(\omega)|^2 = \left| \frac{1}{1 + j\omega} \right|^2 = \frac{1}{1 + \omega^2}$$

$$\text{Then, } P_{no} = \frac{1}{2\pi} \int_{-\infty}^{\infty} |D(\omega)|^2 d\omega = \frac{1}{\pi} \int_0^{\infty} \frac{d\omega}{1 + \omega^2} = \frac{1}{\pi} \tan^{-1}(\omega) \Big|_0^{\infty} = 0.5 \text{ [W]}$$

33. 20.06.2005 final exam

Draw ASK ($A_0=1, A_1=2$), FSK ($f_0 = \frac{3}{4} f_1$) and PSK ($\Delta\Phi = \pi$) waveforms for the binary sequence $S_b=001011$ and given carrier signal.

Solution

The carrier (given) is the first waveform (shown black). The other three waveforms are the answers to the question (shown red). In FSK original carrier frequency is assumed to be f_0 .

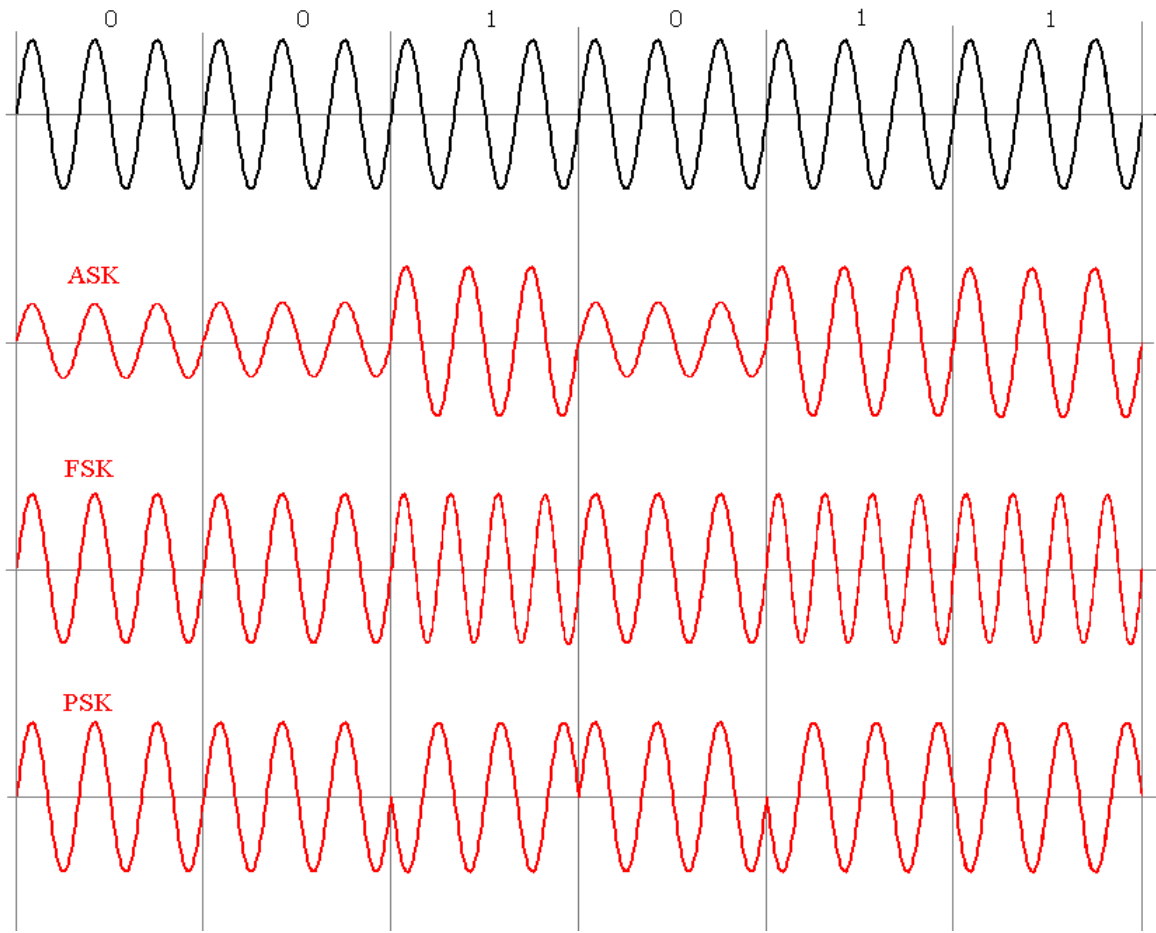

34. 29.03.2006 1st midterm

Estimate the magnitude spectrum of the DSB-SC modulation of the SSB signal (with un-suppressed carrier) whose magnitude spectrum is given below. DSB-SC modulation carrier is given as $x(t) = \cos(\omega_c t)$. Comment on the use of the operation.

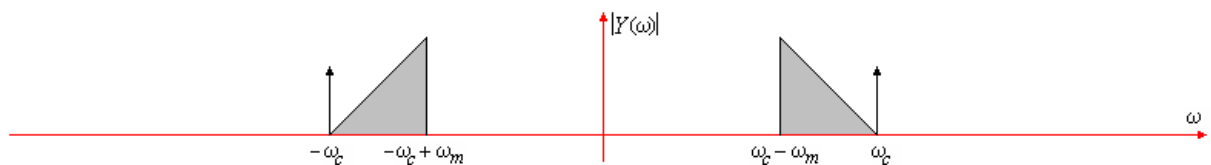

Solution

The given signal is $y(t) = x(t) \cos(\omega_c t) + \hat{x}(t) \sin(\omega_c t) + A \cos(\omega_c t)$ which is the sum of the LSB signal and some carrier. DSB-SC modulation of the carrier $\cos(\omega_c t)$ with this signal is just the multiplication of two and gives

$u(t) = x(t) \cos^2(\omega_c t) + \hat{x}(t) \sin(\omega_c t) \cos(\omega_c t) + A \cos^2(\omega_c t)$. Using trigonometric identities $\cos^2 A = \frac{1}{2} + \frac{1}{2} \cos(2A)$ and $\cos A \sin A = \frac{1}{2} \sin(2A)$ we write

$u(t) = \frac{1}{2} x(t) + \frac{1}{2} LSB(2\omega_c) + \frac{1}{2} A + \frac{1}{2} \cos(2\omega_c t)$ whose magnitude spectrum shown below.

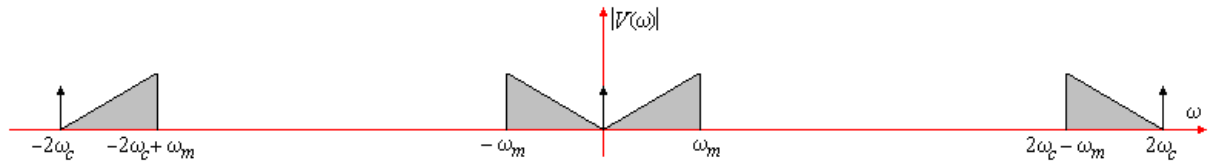

This seems to be a synchronous demodulation of SSB if followed by a LPF for baseband signal extraction. If there is a phase difference between the carrier and the carrier of the SSB then phase errors occur in the baseband.

35. 29.03.2006 1st midterm

Find the total energy spent on the resistor at the output of the ideal bandpass filter.

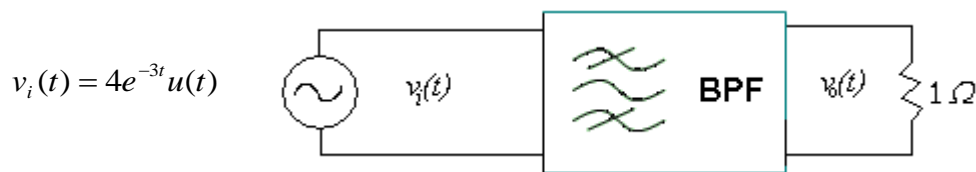

Ideal bandpass filter characteristic is given as
$$H(f) = \begin{cases} 0 & , \quad |f| < 1 \\ 1 & , \quad 1 \leq |f| \leq 2 \\ 0 & , \quad |f| > 2 \end{cases}$$

Solution

Input to the filter in freq. domain shall be found using Fourier tables or Fourier integral

$$V_i(\omega) = F\{v_i(t)\} = \int_0^{\infty} 4e^{-3t} e^{-j\omega t} dt \quad \text{so that} \quad V_i(\omega) = \frac{4}{3 + j\omega} \quad \text{or} \quad V_i(f) = \frac{4}{3 + j2\pi f}$$

$$\text{The energy at the output is then } E = \int_{-\infty}^{\infty} |V_o(f)|^2 df = \int_{-\infty}^{\infty} |V_i(f)H(f)|^2 df = 2 \int_1^2 \left| \frac{4}{3 + j2\pi f} \right|^2 df$$

The multiplier 2 comes here because of the negative side of the spectrum which is identical to the positive side in energy density.

$$E = 2 \int_1^2 \frac{16}{9 + 4\pi^2 f^2} df = \frac{32}{4\pi^2} \int_1^2 \frac{df}{f^2 + (3/2\pi)^2}$$

$$E = \frac{16}{3\pi} \left[\tan^{-1} \left(\frac{2\pi f}{3} \right) \right]_1^2 = \frac{16}{3\pi} \left(\tan^{-1} \left(\frac{4\pi}{3} \right) - \tan^{-1} \left(\frac{2\pi}{3} \right) \right)$$

$$E = \frac{16}{3\pi} (1.3365 - 1.1253) = 0.358 \text{ [Joules]}$$

36. 29.03.2006 1st midterm

Draw ASK ($A_0=1, A_1=0$), FSK ($f_0 = \frac{3}{4} f_1$) and PSK ($\Delta\Phi = \pi$) waveforms for the binary sequence Sb=010011 and given carrier signal below. (carrier magnitude is 1).

Solution

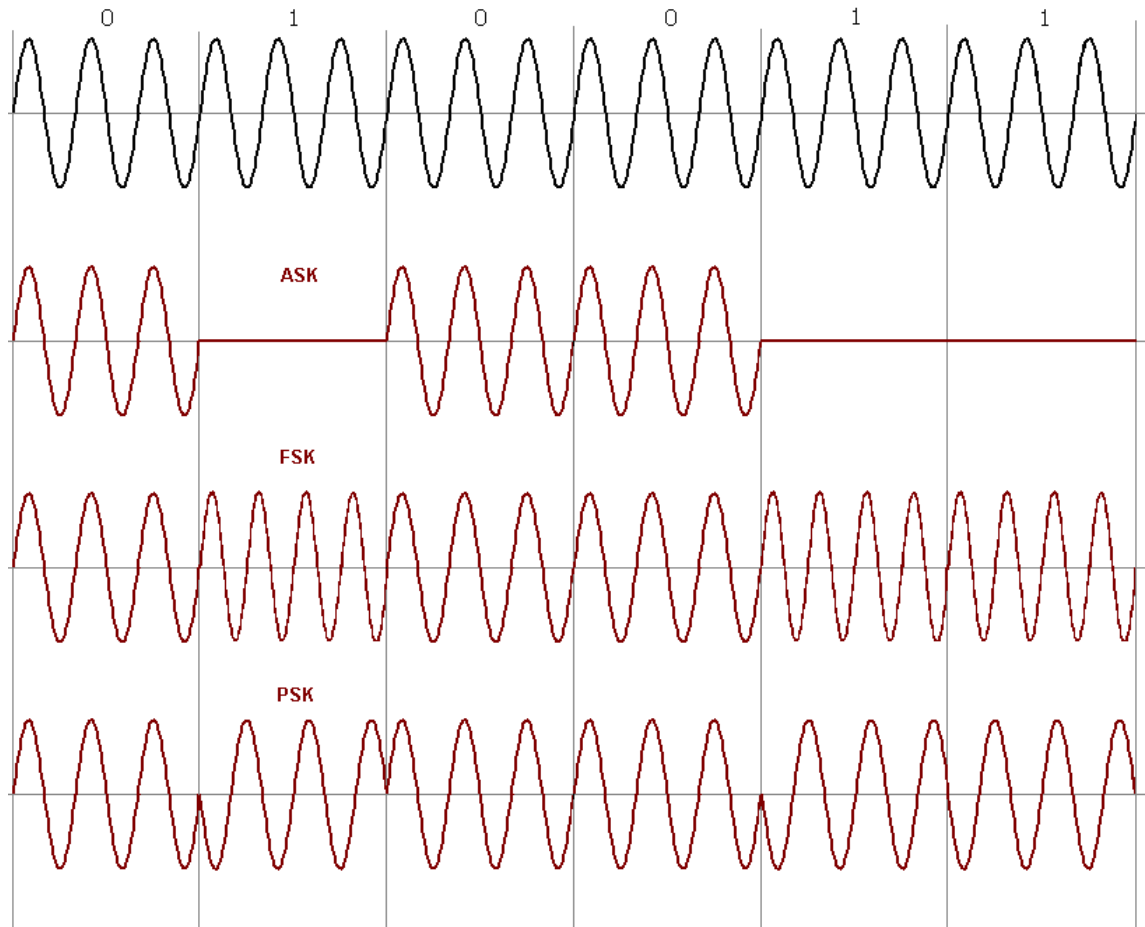

The carrier (given) is the first waveform (shown black). The other three waveforms are the answers to the question (shown brown). In FSK original carrier frequency is assumed to be f_0 . In PSK in-phase carrier represents a 0 whereas 180° shifted one represents a 1.

37. 02.05.2006 2nd midterm

The input of a linear time invariant system is an ergodic random process $x(t)$. $|X(\omega)|$ and $|H(\omega)|$ are given. Find $E\{Y\}$ (expected value of the output).

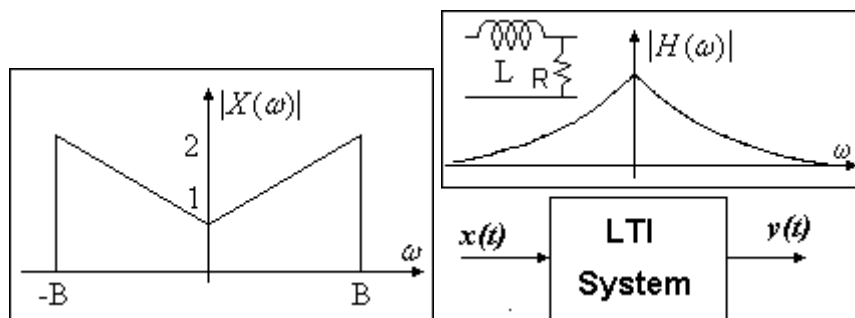

Solution

$E\{Y\} = m_y$ depends only on m_x and $H(\omega)$ at $\omega = 0$. That is $E\{Y\} = m_y = m_x H(0)$. For the given LR circuit $H(0) = 1$. m_x equals to the DC value of $x(t)$ which is given as 1 in the $|X(\omega)|$ spectrum. So, $E\{Y\} = 1 \times 1 = 1$,

38. 02.05.2006 2nd midterm

On a differential binary, line binary zero (0) and one (1) are represented by -0.85 and 0.85 Volts respectively. At the receiver-end the signal is sampled as shown. The decision circuitry uses 0 V as threshold. The line is under AWN whose pdf is shown. The probability of transmitting a binary 0 is 0.7. Calculate the probability of decision error at the receiver.

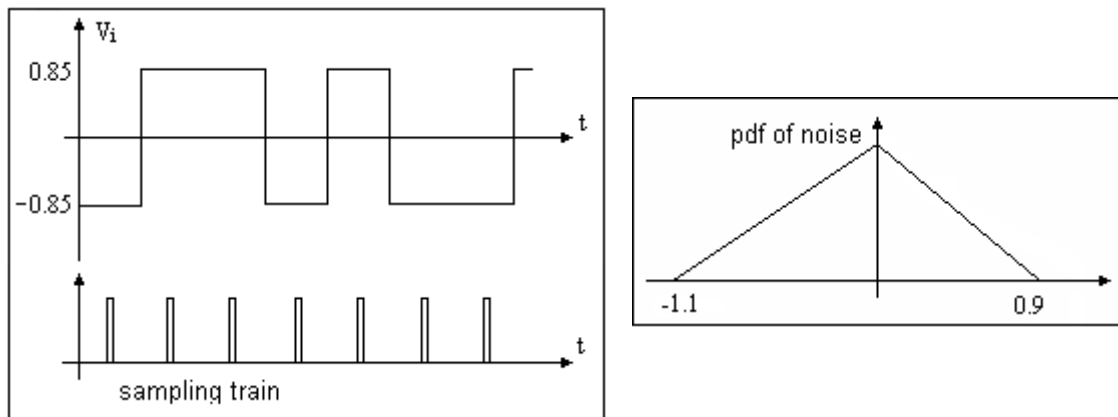

Solution

The probabilities of receiving 1 when 0 was sent and receiving 0 when 1 was sent are the areas shown.

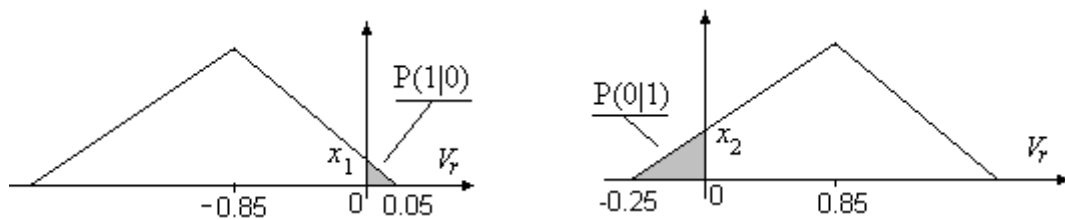

Using similarity of triangles $x_1 = \frac{0.05}{0.9}$ and $x_2 = \frac{0.25}{1.1}$. The areas are then

$$P(1|0) = \frac{0.05}{0.9} \times 0.05 / 2 = \frac{0.0025}{1.8} \cong 0.0014 \text{ and}$$

$$P(0|1) = \frac{0.25}{1.1} \times 0.25 / 2 = \frac{0.0625}{12.2} \cong 0.0284.$$

Summing the error probabilities $P_e = P(0)P(1|0) + P(1)P(0|1)$

$$P_e = 0.7 \times 0.0014 + 0.3 \times 0.0284 \cong 0.0095$$

39. 02.05.2006 2nd midterm

A LPF with $R=1k\Omega$ is given. White Gaussian noise at the input has the power spectral density of $S_n(\omega) = \frac{N_0}{2} = 10^{-12} [W / Hz]$. In order for the total output noise power P_{no} to be less than $6.28 \times 10^{-3} [\mu W]$ find the minimum value of the capacitor C .

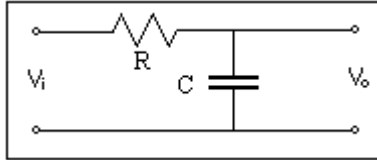

Solution

$$H(j\omega) = \frac{1}{1 + j\omega RC}, \text{ and } |H(\omega)| = \frac{1}{\sqrt{1 + \omega^2 R^2 C^2}}$$

$$\text{Also } S_o(\omega) = S_i(\omega) |H(\omega)|^2$$

$$\text{And the power is the integral of the psd } P_o = \frac{1}{2\pi} \int_{-\infty}^{\infty} S_o(\omega) d\omega = \frac{N_0}{2\pi} \int_0^{\infty} \frac{d\omega}{1 + \omega^2 R^2 C^2}$$

$$P_o = \frac{N_0}{2\pi R^2 C^2} \int_0^{\infty} \frac{d\omega}{\omega^2 + \frac{1}{R^2 C^2}} = \frac{N_0}{2\pi R^2 C^2} RC \tan^{-1}(RC\omega) \Big|_0^{\infty} = \frac{N_0}{2\pi RC} [\tan^{-1}(\infty) - \tan^{-1}(0)]$$

$$P_o = \frac{10^{-12}}{1 \times 10^3 \times \pi \times C} \frac{\pi}{2}$$

For this to be equal to the maximum allowed noise power C should be

$$C = \frac{10^{-12}}{1 \times 10^3 \times 6.28 \times 10^{-9} \times 2} \cong 0.08 \times 10^{-6} [F] = 80 [nF] \text{ (minimum capacitance.)}$$

(The following are there to answer some questions from students regarding $\omega = 2\pi f$).

$$\text{Using } f \text{ (Hertz) we have } S_o(f) = S_i(f) |H(f)|^2 = \frac{N_0}{2} |H(f)|^2$$

$$\text{Since } \omega = 2\pi f \text{ we also have } |H(f)|^2 = \frac{1}{1 + 4\pi^2 f^2 R^2 C^2}$$

$$P_o = \int_{-\infty}^{\infty} S_o(f) df = \int_{-\infty}^{\infty} \frac{N_0}{2} \frac{df}{1 + 4\pi^2 f^2 R^2 C^2} = \frac{N_0}{8\pi^2 R^2 C^2} \int_{-\infty}^{\infty} \frac{df}{f^2 + (\pi RC)^{-2}}$$

$$P_o = \frac{N_0}{8\pi^2 R^2 C^2} [2\pi RC \tan^{-1}(2\pi RCf)]_{-\infty}^{\infty} = \frac{N_0}{4RC}$$

$$C_{\min} = \frac{N_0}{4RP_{\max}} = \frac{10^{-12}}{2 \times 1 \times 10^3 \times 6.28 \times 10^{-9}} \cong 80 [nF]$$

That is, $1/2\pi$ has already answered the questions right in the beginning. ☺

40. 02.06.2006 final exam

Interestingly band-limited noise with flat spectral density at the input of a deemphasizer has the following spectral (power) characteristic;

$$N(f) = \begin{cases} N_0/2 & , -f_N < f < f_N \\ 0 & , \textit{otherwise} \end{cases} . \text{ The deemphasizer filter is } |D(f)| = \frac{1}{\sqrt{f^2 + f_c^2}} .$$

Find filter cutoff frequency f_c for the output noise power to be half of the input noise power.

Solution

$$P_n = \int_{-\infty}^{\infty} N(f)df = \int_0^{f_N} N_0 df = N_0 f_N \text{ (noise power without deemphasizer)}$$

$$P_{dn} = \int_0^{f_N} \frac{N_0}{f^2 + f_c^2} df = \frac{N_0}{f_c} \tan^{-1}(f/f_c) \Big|_0^{f_N} = \frac{N_0}{f_c} \tan^{-1}(f_N/f_c) \text{ (power with deemphasizer)}$$

$$P_n = 2P_{dn} \Rightarrow N_0 f_N = \frac{2N_0}{f_c} \tan^{-1}\left(\frac{f_N}{f_c}\right) , f_c f_N = 2 \tan^{-1}\left(\frac{f_N}{f_c}\right)$$

$$\tan\left(\frac{f_c f_N}{2}\right) = \frac{f_N}{f_c} . \text{ Closed form equation can be solved numerically.}$$

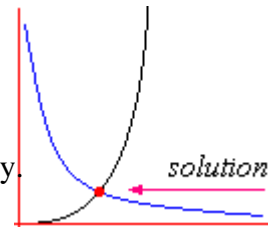

41. 02.06.2006 final exam

A message signal $m(t) = \cos(4\pi t) + \sin(3\pi t + \pi)$ SSB (USB) modulates the carrier $c(t) = \cos(20\pi t)$. Find modulated signal $y_{USB}(t)$ and sketch its frequency spectrum.

Solution

$$x(t) = m(t)c(t) - \hat{m}(t)\hat{c}(t)$$

$$x(t) = (\cos(4\pi t) - \sin(3\pi t))\cos(20\pi t) - (\sin(4\pi t) + \cos(3\pi t))\sin(20\pi t)$$

$$x(t) = \cos(4\pi t)\cos(20\pi t) - \sin(3\pi t)\cos(20\pi t) - \sin(4\pi t)\sin(20\pi t) - \cos(3\pi t)\sin(20\pi t)$$

$$x(t) = \frac{1}{2}(\cos(16\pi t) + \cos(24\pi t)) + \sin(17\pi t) - \sin(23\pi t)$$

$$- \cos(16\pi t) + \cos(24\pi t) - \sin(17\pi t) - \sin(23\pi t)$$

$$x(t) = \cos(24\pi t) - \sin(23\pi t)$$

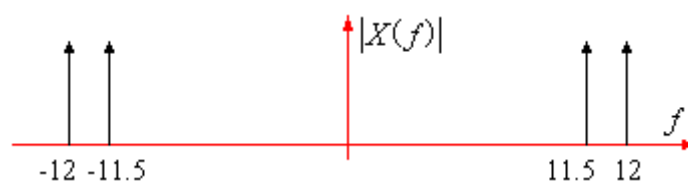

42. 02.06.2006 final exam

Determine if the following signal is power or energy type and find its energy/power value.

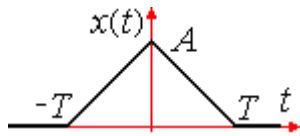

Solution

Since $x(t)$ is both time and magnitude limited it is an energy signal

$$E = 2 \int_0^T \left| \frac{-At}{T} + A \right|^2 dt = 2 \int_0^T \left| \frac{At}{T} \right|^2 dt = \frac{2A^2}{3T^2} t^3 \Big|_0^T = \frac{2}{3} A^2 T$$

43. 02.06.2006 final exam

A 10 km binary transmission line is supported by N regenerative repeaters. (A regenerative repeater is a device which repeats the input binary signal by detecting the input bit and outputting the corresponding signal level. This way distortion and noise are eliminated before they overwhelm the signal.) Assume that the additive noise does not increase by the length of the line segment for simplicity. But the signal strength goes down by the distance and is formulated by $V = \frac{\pm 100}{100 + m}$, where m is the distance from the source in km. Noise pdf is below. Calculate the probability of incorrect reading at the receiver when we have $N=1$ and $N=4$ repeaters (2 and 5 line segments, correspondingly).

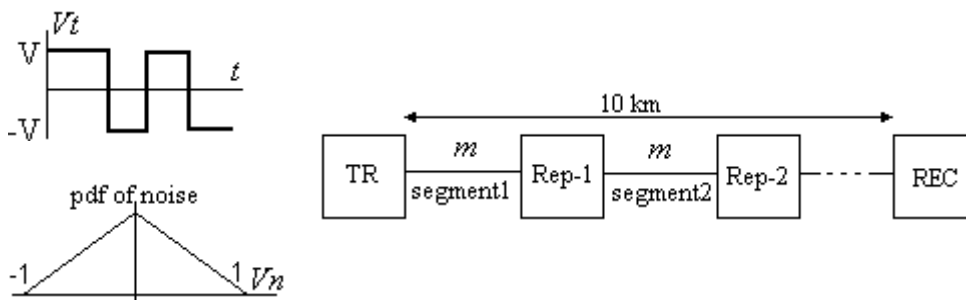

Solution

$$\frac{100}{100 + m} + u = 1 \Rightarrow u = \frac{m}{100 + m}$$

$$e = \int_0^{\frac{m}{100+m}} V_t dV_t = \frac{V_t}{2} \Big|_0^{\frac{m}{100+m}} = \frac{\frac{1}{2} m^2}{(100 + m)^2}$$

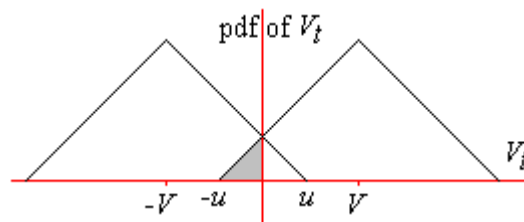

$$N = 1 \Rightarrow m = \frac{10}{N+1} = 5 \Rightarrow e_1 = \frac{\frac{1}{2}5^2}{(100+5)^2} \cong 0.001134,$$

$$N = 4 \Rightarrow m = \frac{10}{N+1} = 2 \Rightarrow e_4 = \frac{\frac{1}{2}2^2}{(100+2)^2} \cong 0.000192$$

$$E_1 = 1 - (1 - e_1)^2 \cong 1 - (1 - 0.01134)^2 = 0.002266$$

$$E_4 = 1 - (1 - e_4)^5 \cong 1 - (1 - 0.000192)^5 = 0.000961$$

44. 12.06.2006 final exam makeup

A 10 km binary transmission line is supported by N regenerative repeaters. (A regenerative repeater is a device which repeats the input binary signal by detecting the input bit and outputting the corresponding signal level. This way distortion and noise are eliminated before they overwhelm the signal.) Assume that the AWG noise with $\sigma = 1$ does not increase by the length of the line segment (for simplicity). But the signal strength goes down by the distance and is formulated by $V = \frac{\pm 30}{10+m}$, where m is the distance from the source in km. Draw the graph of probability of incorrect reading at the destination (receiver) vs. the number of uniformly located repeaters. (P_e vs. N)

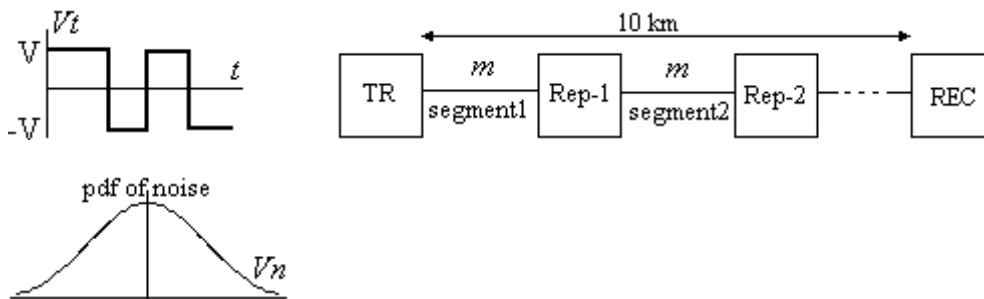

Solution

Probability of error for single stage is (no repeater, just receiver, $N=0$, $m=10$):

$$P_e = \frac{1}{\sqrt{2\pi}} \int_V^{\infty} e^{-\frac{t^2}{2}} dt \text{ which equals to the area shown}$$

$$P_e = 1 - \text{erf}(V)$$

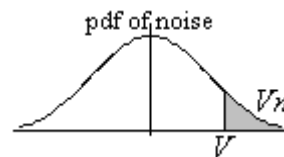

Actually V is at the center of the Gaussian and the point indicated is at the zero-treshold, but this makes no difference in calculations. The following are single stage errors;

For $N=0$ (no repeater) $m=10$, $V = 30/20 = 1.5$, $P_e = 1 - \text{erf}(1.5) = 0.0668$

For $N=1$ (one repeater) $m=5$, $V = 30/15 = 2$, $P_e = 1 - \text{erf}(2.0) = 0.0228$

For $N=2$ (two repeaters) $m=3.33$, $V = 30/13.33 = 2.25$, $P_e = 1 - \text{erf}(2.25) = 0.0122$

For $N=3$ (three repeaters) $m=2.5$, $V = 30/12.5 = 2.4$, $P_e = 1 - \text{erf}(2.4) = 0.0082$

For $N=4$ (four repeaters) $m=2$, $V = 30/12 = 2.5$, $P_e = 1 - \text{erf}(2.5) = 0.0062$

$$P_{tot0} = 0.0668$$

$$P_{tot1} = 1 - (1 - 0.0228)^2 = 0.0451$$

$$P_{tot2} = 1 - (1 - 0.0122)^3 = 0.0362$$

$$P_{tot3} = 1 - (1 - 0.0082)^4 = 0.0324$$

$$P_{tot4} = 1 - (1 - 0.0062)^5 = 0.0306$$

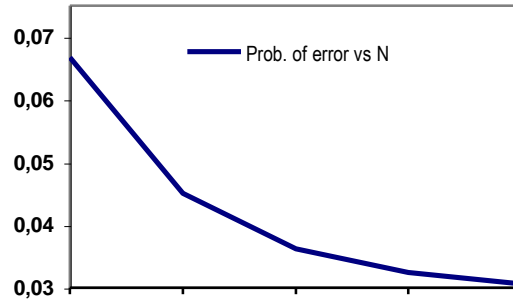

45. 12.06.2006 final exam makeup

Given $x(t) = \cos(5\pi t) + \sin(3\pi t + \pi)$ and $c(t) = \cos(20\pi t)$, find $y(t)$ and draw its frequency spectrum.

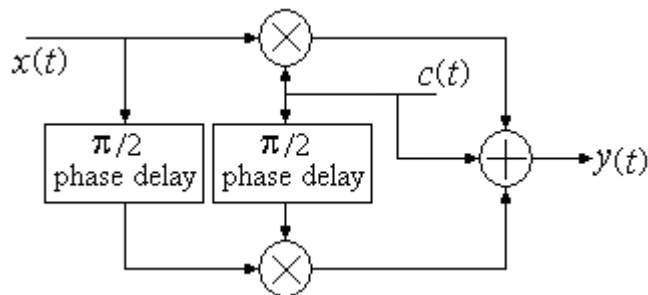

Solution

$$\dot{x}(t) = \sin(5\pi t) + \cos(3\pi t)$$

$$\dot{c}(t) = \sin(20\pi t)$$

$$\begin{aligned} \dot{x}(t)\dot{c}(t) &= \sin(20\pi t)\sin(5\pi t) + \sin(20\pi t)\cos(3\pi t) \\ &= \frac{1}{2}(\cos(15\pi t) - \cos(25\pi t) + \sin(17\pi t) + \sin(23\pi t)) \end{aligned}$$

$$\begin{aligned} x(t)c(t) &= \cos(20\pi t)(\cos(5\pi t) - \sin(3\pi t)) \\ &= \frac{1}{2}(\cos(15\pi t) + \cos(25\pi t) + \sin(17\pi t) - \sin(23\pi t)) \end{aligned}$$

$$\begin{aligned} y(t) &= \dot{x}(t)\dot{c}(t) + x(t)c(t) + c(t) \\ &= \frac{1}{2}(\cos(15\pi t) - \cos(25\pi t) + \sin(17\pi t) + \sin(23\pi t) + \cos(15\pi t) \\ &\quad + \cos(25\pi t) + \sin(17\pi t) - \sin(23\pi t) + \cos(20\pi t)) \\ y(t) &= \cos(15\pi t) + \sin(17\pi t) + \cos(20\pi t) \end{aligned}$$

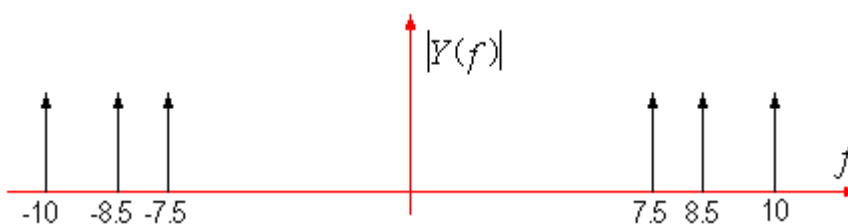

46. 24.03.2007 1st midterm exam (following 10 questions)

1) What would be the mag-freq-spectrum of the output of the given system?

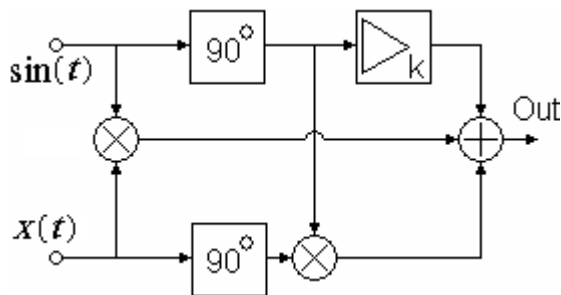

The choices are

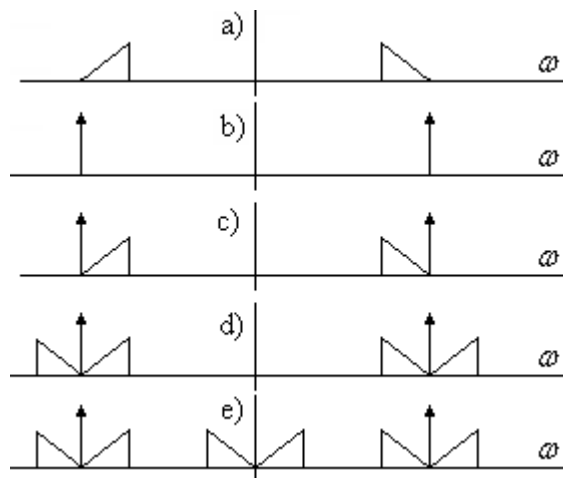

Solution

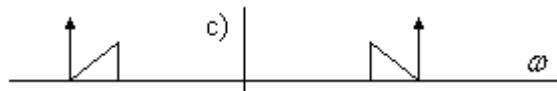
The answer is  since without the amplifier with gain k the system is a Single Side Band AM (SSB). Additionally we have some carrier inserted at the output..

2) Fundamental frequency of the given periodic signal is at $\omega_0 = \pi/4$ rd/s. What is the magnitude of the component at zero frequency?

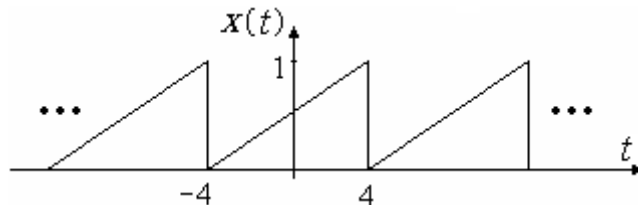

- a) 1 b) 4 c) π d) 3π e) 0

Solution

Mean value of the signal is 0.5. Since $1 \Leftrightarrow 2\pi\delta(\omega)$ we conclude that the answer is $0.5 \times 2\pi = \pi$ (selection c).

- 3) It is given that $\Pi\left(\frac{t}{T}\right) \Leftrightarrow T \operatorname{sinc}\left(\frac{\omega T}{2\pi}\right)$. What would be the FT of

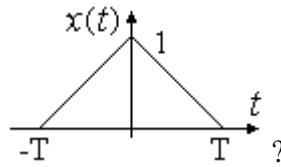

The choices are

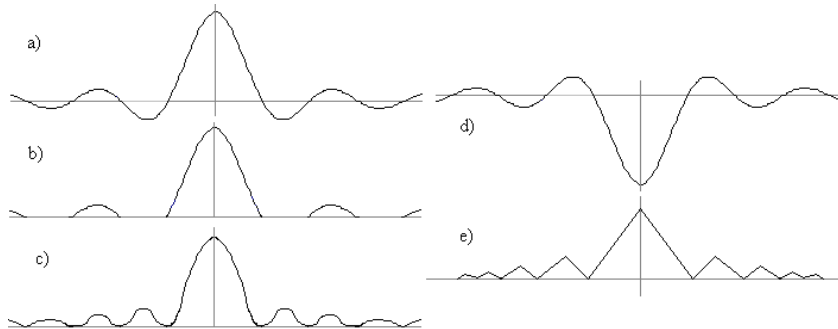

Solution

Although it is possible to find the answer by calculating the Fourier transform of the given waveform, this is not necessary. After eliminating all other answers on the basis that they cannot be the FT of the given waveform what remains is the answer below.

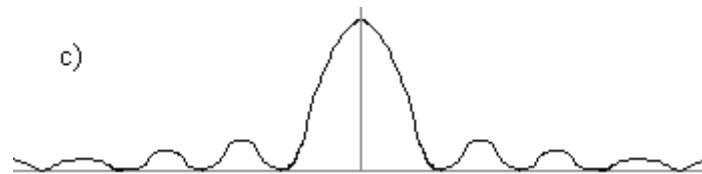

Hint : We could also use the convolution property of the FT. Start with the FT of two identical gate Π signals and write down their convolution (multiplication in FT domain).

- 4) $x(t) = 2 + \sin(100\pi t) - 4\cos(10\pi t + \pi/3) - 2\sin^2(12\pi t - \pi/3)$ is given. What are the values of $|X(\omega)|$ at $\omega_1 = +10\pi$ rd/s. and $\omega_2 = 0$ rd/s?

The choices are a) $2\pi, 3\pi$ b) $3\pi, 2\pi$ c) $4\pi, 0$ d) $4\pi, 2\pi$ e) $0, 0$

Solution

The sinusoidal term $-4\cos(10\pi t + \pi/3)$ has a component at $\omega_1 = +10\pi$. Using the FT pair $\sin(\omega_0 t) \Leftrightarrow \frac{\pi}{j}[\delta(\omega - \omega_0) - \delta(\omega + \omega_0)]$, we see that the component at given frequency has a magnitude of 4π . Since $\sin^2 A = \frac{1}{2} - \frac{1}{2}\cos(2A)$ (a trigonometric identity), the DC value of the signal is 1. Considering the FT pair $1 \Leftrightarrow 2\pi\delta(\omega)$ again, we conclude that the answer is d.

- 5) $\cos(\omega_c t)$ is the signal used to generate SSB signal $y_{USB}(t)$ and it is generated at the receiver and synchronized with the original one at the transmitter. What should be in the following, in order to obtain $\hat{x}(t)$, the baseband signal whose bandwidth is upto ω_1 ?

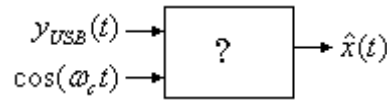

The multiple choices are below

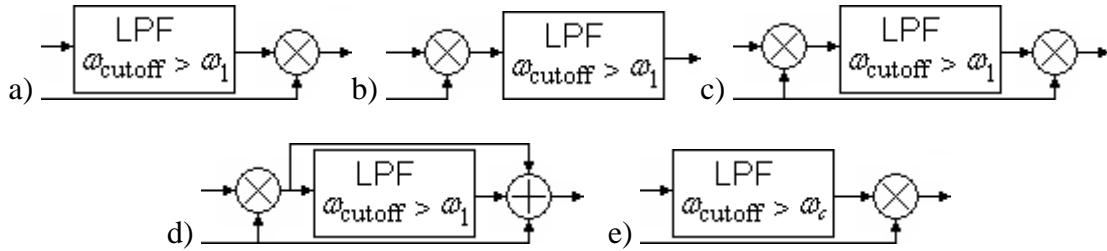

Solution

A synchronous demodulation followed by a low-pass filter with cutoff frequency a little higher than ω_1 would suffice. So the answer is b.

- 6) What is the energy and power contained in the given signal?

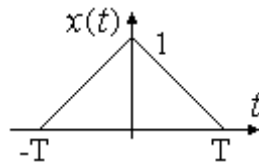

- a) $E=3T/2, P=0$ b) $E=\infty, P=2T$ c) $E=0, P=3T$ d) $E=2T/3, P=0$ e) $E=\infty, P=3T/2$

Solution

$$E = \int_{-\infty}^{\infty} |x(t)|^2 dt = 2 \int_{-T}^0 \left| \frac{t}{T} + 1 \right|^2 dt = 2 \left[\frac{t^3}{3T^2} + \frac{t^2}{T} + t \right]_{-T}^0 = \frac{2T}{3}$$

Energy is found to be finite, therefore the power is zero. The answer, then, is d.

- 7) What should be the relation between R and C in the given circuit for the value of output power spectral density function to be half of the input psd value at $\omega_c = 1$?

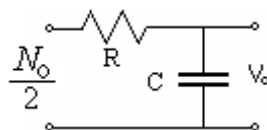

- a) $C=R$ b) $C=1-R$ c) $C = \omega_c R$ d) $C=1/R$ e) $C = \omega_c R^2$

Solution

$$G_o(\omega) = G_i(\omega)|H(\omega)|^2 = \frac{N_0}{2} \frac{1}{1 + \omega^2 R^2 C^2}$$

We want $G_o(\omega_c) = \frac{N_0}{4}$. Combining two equations, we get

$$1 = \frac{2}{1 + \omega_c^2 R^2 C^2} \text{ and from here we get } R = \frac{1}{C} \text{ when } \omega_c = 1. \text{ Answer is d.}$$

8) Power spectral density of a signal is given to be

$$G(f) = \begin{cases} \cos(f) & , |f| < \frac{\pi}{4} \\ 0 & , elsewhere \end{cases}$$

What is the total power?

- a) $\sqrt{3}$ b) 1 c) π d) $\sqrt{2}$ e) $\frac{\pi}{4}$

Solution

$$P_T = \int_{-\infty}^{\infty} G(f)df = \int_{-\pi/4}^{\pi/4} \cos(f)df = \sin(f) \Big|_{-\pi/4}^{\pi/4} = \sqrt{2} . \text{ The answer is d.}$$

9) What could be the message signal when conventional AM modulated signal is given as shown and the modulation index is one?

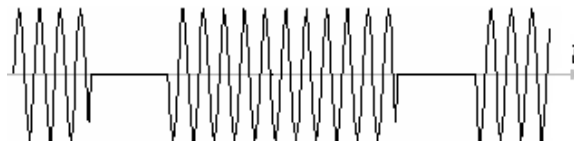

Multiple choices are given below

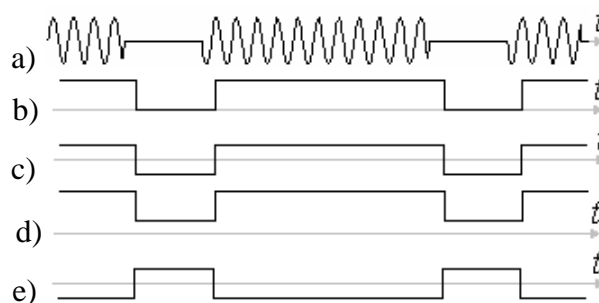

Solution

Given modulated signal is an ASK signal which has two discrete levels. One of the levels should be zero as understood from the given signal. The only message signal which is zero valued at the corresponding locations is given in b.

10) What is the frequency spectrum of $x(t) = 1 + 3\sin(t) + 4\cos(t)$?

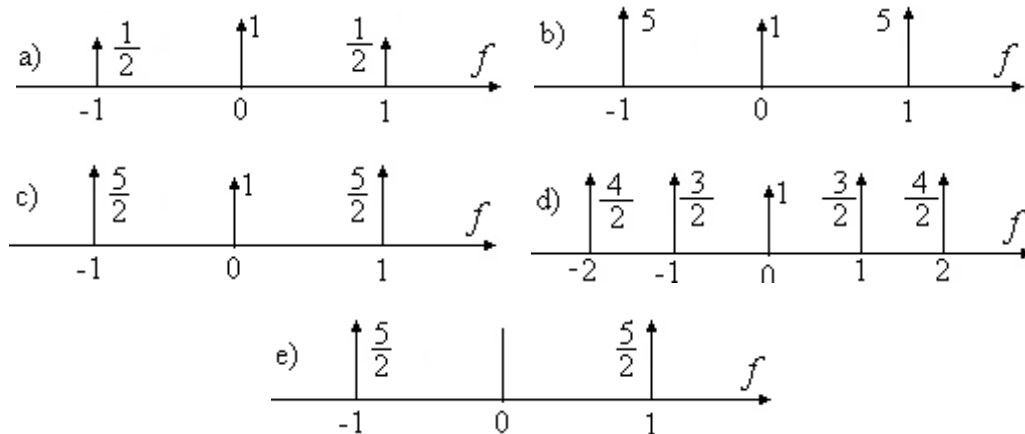

Solution

The signal $x(t)$ has components at frequencies $+1$, -1 and 0 . Since sinusoidal signals $\sin(\cdot)$ and $\cos(\cdot)$ have the same frequency they are added to form a phase shifted sinusoidal waveform. The amount of phase shift is determined by the magnitudes of the terms. Extreme cases are when $\cos(\cdot)$ term is zero and when $\sin(\cdot)$ term is zero. We would have 90° and 0° shifted sinusoidals respectively in these cases. The magnitude and phase shift in other cases can be found using $\sqrt{x^2 + y^2}$ and $\tan^{-1}(x/y)$ where x and y are the magnitudes of $\sin(\cdot)$ and $\cos(\cdot)$ terms respectively (relative to the first one). $\sqrt{3^2 + 4^2} = 5$. This points at the answer c which also confirms the DC term.

47. 30.04.2007 2nd midterm exam (following 10 questions)

1) A baseband signal whose power spectral density is given below was sampled, but it was seen that upper 2 kHz band of the signal is aliased. What was the sampling frequency which caused this aliasing?



- a) 7 kHz b) 5 kHz c) 12 kHz d) 14 kHz e) 2 kHz f) 9 kHz

Solution

In order not to have aliasing, the sampling frequency must be higher than twice the highest frequency in the signal. In our case, sampling frequency must be 14 kHz. But since upper 2 kHz of the signal is aliased, we conclude that the sampling frequency applied was 12 kHz instead.

- 2) Identify the TV signal component indicated with an arrow.



- a) v-sync b) color-burst c) h-sync d) raster e) composite f) QAM

Solution

A local oscillator at the TV receiver synchronizes with a component of the TV-signal. The component is added to the color TV signal at the back-porch of the every horizontal sync pulse before the line video signal starts. This signal is called color-burst. TV receiver compares the chrominance components' phase with the phase of the locally generated signal and generates color signals. The answer is b.

- 3) Identify the TV signal spectrum component pointed at with an arrow.

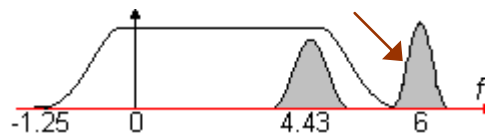

- a) audio b) video carrier c) chrominance d) luminance e) color signal f) VSB

Solution

Audio signal of TV uses FM and is carried at a frequency 6 MHz higher than the video carrier of the channel. So the answer to the question is a.

- 4) The input to the LTI system given is AWGN with $m = 1$ and $\sigma^2 = 1$. What is the mean value of the output? ($R=C=1$)

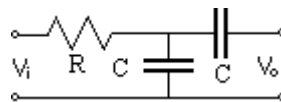

- a) $\sqrt{2}$ b) 1 c) $2\sqrt{2}$ d) 0 e) e^{-1} f) _____

Solution

Although it is misleading to draw without an output load as shown, it common to isolate DC levels of the cascaded stages of electronic devices using capacitors. That is, the serial capacitor at the output does not allow zero frequency component to pass. This means the mean value of the output is zero. Therefore the answer is d.

- 5) Determine the probability of having X greater than -0.4 when CDF of r.v. X is as given.

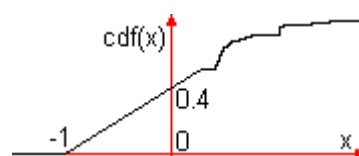

- a) 0.42 b) 0.76 c) 0.60 d) 0.34 e) 0.40 f) _____

Solution

CDF gives the probability of r.v. being less than a given value. The linear portion of the CDF allows us to calculate the value at -0.4. $cdf(x) = 0.4x + 0.4$ is the CDF at the linear section. The value of the CDF at $x = -0.4$ is $P(x < -0.4) = 0.4 \times (-0.4) + 0.4 = 0.24$. Using this we calculate the answer as $P(x > -0.4) = 1 - 0.24 = 0.76$, and see that the answer is b.

- 6) The input to the LTI system given is AWGN with $m = 1$, $\sigma^2 = 1$ and power spectral density of $\mathcal{N}_0/2$. What is the output spectral density? (R=C=1)

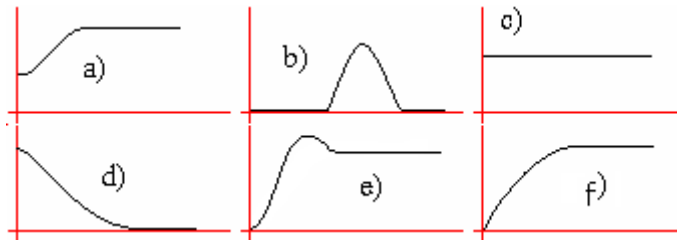
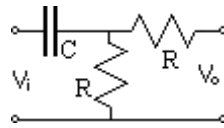

Solution

The circuit given is a first order high-pass-filter. Since input is a flat spectrum noise, the output noise should gradually increase to that level starting from zero at zero frequency. The answer is f.

- 7) What is the probability of having the value of r.v. X between 1 and 3 when PDF of X is Gaussian with $m = 2$ and $\sigma^2 = 1$?

- a) 0.1587 b) 0.0228 c) 0.0014 d) 0,3173 e) 0.5 f) 0.6827

Solution

Since $\sigma^2 = 1$ we can use Q(x) tables directly keeping in mind that the mean is 2, which is the center point of given two values, 1 and 3. That is

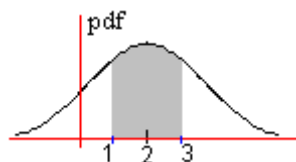

The shaded area is what we need to find, $P(1 < x < 3)$. This is identical to finding $P(-1 < x < 1)$ when mean of the pdf is moved to zero.

- 8) Two identical amplifiers with $H_{max}=10$ and $F=5$ are cascaded. What is the noise figure of the resulting two-stage amplifier?

a) 10 b) 7.5 c) 25 d) 100 e) 6.14 f) 5.04

Solution

We know that $F = F_1 + \frac{F_2 - 1}{H_{1max}^2} + \frac{F_3 - 1}{H_{1max}^2 H_{2max}^2} + \dots + \frac{F_n - 1}{\prod_{i=1}^n H_{imax}^2}$ for n -cascaded amplifiers.

Therefore, the answer for our 2-stage amplifiers is $F = 5 + \frac{5-1}{10^2} = 5.04$

- 9) What is the noise equivalent bandwidth of the given LTI system when input to the system is white-noise with spectral density of $N_0/2$?

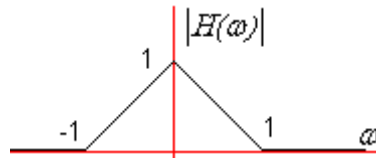

a) $\frac{1}{6\pi}$ b) N_0 c) $\frac{N_0}{4\pi}$ d) $\frac{N_0}{3\pi}$ e) $\frac{N_0}{2}$ f) _____

Solution

The output noise power is $P_o = \frac{1}{2\pi} \int_{-\infty}^{\infty} \frac{N_0}{2} |H(\omega)|^2 d\omega = \frac{N_0}{2\pi} \int_{-1}^1 \omega^2 d\omega = \frac{N_0}{2\pi} \left[\frac{\omega^3}{3} \right]_{-1}^1 = \frac{N_0}{6\pi}$.

Let us consider a flat ideal filter with a bandwidth B , and write down its output noise

power $P_{ne} = \frac{1}{2\pi} \int_{-B}^B \frac{N_0}{2} d\omega = \frac{N_0 B}{2\pi}$. In order to have same noise power with the actual filter,

we write $P_{ne} = P_o$. That is, $\frac{N_0 B}{2\pi} = \frac{N_0}{6\pi}$. Therefore, $B = \frac{1}{3}$.

- 10) A binary symmetric channel has probability of error $Pe=0.01$. What is the probability of receiving zero (0) when probability of sending zero (0) is 0.3?

a) 0.3 b) 0.7 c) 0.297 d) 0.703 e) 0.304 f) 0.99

Solution

From total probability theorem, we can write

$$P(y = 0) = P(x = 0)P(y = 0 | x = 0) + P(x = 1)P(y = 0 | x = 1) \text{ for BSC.}$$

In our case $P(y = 1 | x = 0) = P_e = 0.01$, $P(y = 0 | x = 0) = 1 - P_e = 0.99$, $P(x = 0) = 0.3$

and $P(x = 1) = 1 - P(x = 0) = 1 - 0.3 = 0.7$. Using these values, we find

$$P(y = 0) = 0.3 \times 0.99 + 0.7 \times 0.01 = 0.304 \text{ as an answer.}$$



48. 31.05.2007 Final Exam (following 11 questions)

1. What is the fundamental frequency of the following periodic waveform?

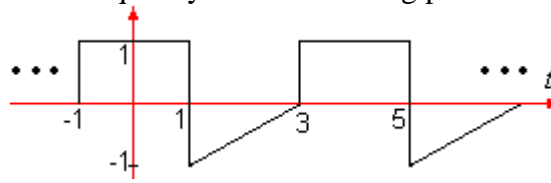

Solution

Fundamental frequency is the lowest frequency of a periodic waveform other than DC component. Generally it is $1/T$ where T is the period. Therefore,

$$f_0 = \frac{1}{T} = \frac{1}{4} = 0.25 \text{ Hz}$$

2. When a SC-DSB-AM short-wave radio station broadcast a tone test signal a spectrum analyzer measured the following. Determine the frequency of the tone signal.

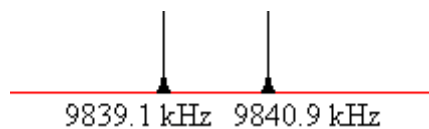

Solution

The carrier frequency modulated by the tone signal would be at the center, and the components of the tone would be seen $\pm f_T$ far from the center where f_T being the frequency of the tone signal. Then,

$$f_T = (9840.9 - 9839.1) / 2 = 0.9 \text{ kHz} = 900 \text{ Hz}$$

3. The following is an approximation to the magnitude of freq. response of a filter designed to attenuate components at frequencies below 2 Hz. Low-Pass noise with given frequency spectrum is at the input of the filter. What is the noise power at the output?

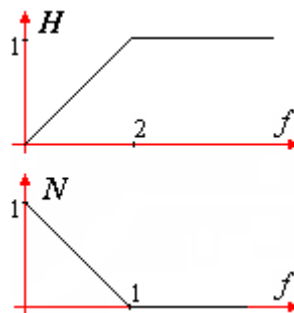

Solution

$$P_{no} = \int_{-\infty}^{\infty} S_{no}(f)df = \int_{-\infty}^{\infty} S_{ni}(f)|H(f)|^2 df$$

From the figures given, $S_{ni} = 1 - f, f < 1$, and $H(f) = \begin{cases} \frac{1}{2}f, & f < 2 \\ 1, & f \geq 2 \end{cases}$ keeping in mind that

the calculated values should be doubled since we have the symmetric characteristics for negative frequencies also.

$$P_{no} = 2 \int_0^1 (1-f)|0.5f|^2 df = \frac{1}{2} \int_0^1 (f^2 - f^3)df = \frac{1}{2} \left[\frac{1}{3}f^3 - \frac{1}{4}f^4 \right]_0^1 = \frac{1}{24} \text{ W}$$

4. The following periodic waveform is a pure sinusoidal of unit peak-to-peak value plus some DC value. Determine the magnitude of the third (3rd) harmonic of the waveform.

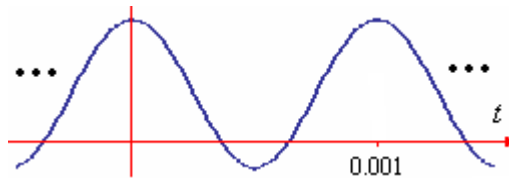

Solution

Pure sinusoids carry no harmonics. That is we only have two dirac-delta impulses at $1/0.001=1000$ Hz and -1000 Hz excluding the DC impulse at zero frequency. Therefore, the answer is **zero** (That is, magnitude of the component at 3rd harmonic, 3 kHz, is obviously zero.)

5. $m(t)$ is the sum of 3 sinusoids with frequencies 1, 2 and 3 Hz as shown in figure. What is the lowest frequency at the SC-USB AM modulator output.

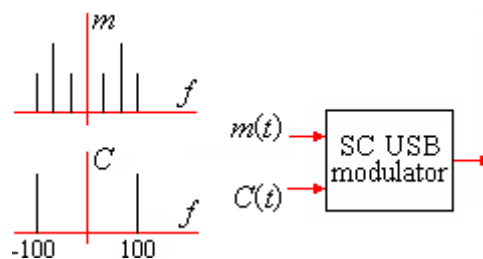

Solution

Upper side band components are higher than the carrier frequency. 1, 2 and 3 Hz components would be seen at the 101, 102 and 103 Hz after modulation. The lowest frequency is **101 Hz** among all.

6. What is the modulation type of the signal shown with an arrow in the frequency spectrum of the color TV signal?

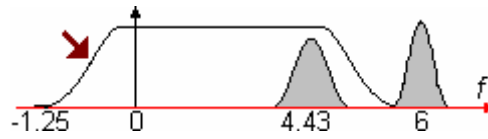

Solution

The component shown is the luminance signal modulated using **VSB** (Vestigial Side Band) modulation. The answer is **VSB**, then.

7. Approximately draw the signal envelope at the FM-AM converter output for given FM signal.

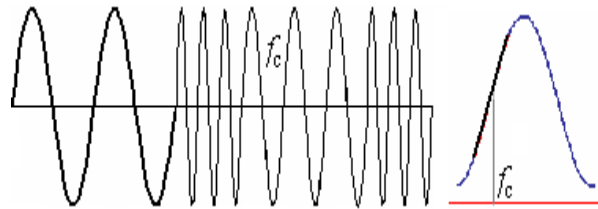

Solution

We see from the frequency characteristic of the FM-AM converter filter that lower the frequency means lower the amplitude at the filter output and higher freq. means higher amplitude. And we see three different frequencies in three different sections of the FM (FSK) signal one of which is marked as f_c . The sinusoids with higher period than this generate lower amplitude as illustrated in the initial part of the signal shown below. Rest of the envelope is drawn similarly.

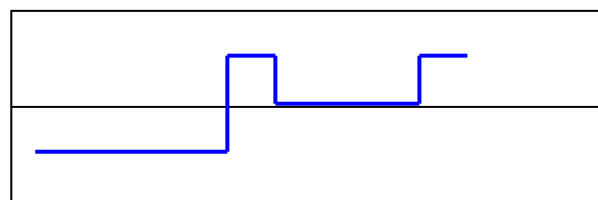

8. What is the name of the pulse at the end of every line video signal of color video signal?

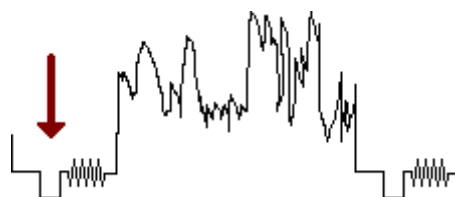

Solution

TV signal has *horizontal synchronization* pulses after completing every scan line and vertical synchronization pulses after completing every field.

9. Old standard for 10Base-T ethernet networks (IEEE 802.3) use Manchester encoding with two voltage levels of -0.85 and +0.85 Volts. A cable carrying such a signal is working in an environment with very strong noise. Noise induces a signal with a pdf given below onto the cable. Assuming two voltage levels has the same probability and decision threshold is 0 V., what is the channel reading error probability?

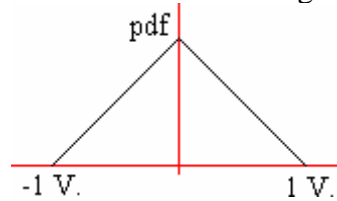

Solution

Looking at the figure in which the distribution of the Manchester signal is given with the decision level right in the middle, we see that the error is represented by the shaded triangular areas.

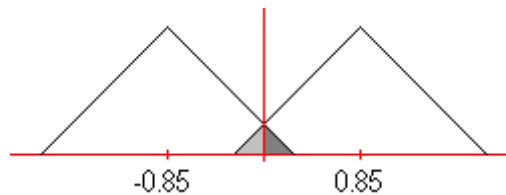

Since two voltage levels are said to have same probability (and two triangles are identical) then we can find the probability of error by just calculating the area of a single triangle.

$$p_e = 0.15 \times 0.15 / 2 = 0.01125$$

In the cases where the distribution is not symmetric and the probabilities of occurrences binary values are not equal we would use the total probability theorem.

$$p_e = p(0)p(1|0) + p(1)p(0|1)$$

Since in our case $p(0) = p(1) = 0.5$ and $p(1|0) = p(0|1) = \text{areas_shown}$ our simple calculation is valid.

10. In the following Huffman code, determine which codeword is wrong (incorrect, non-unique, unnecessarily long or insufficiently short etc) and correct it if possible.

| | |
|---|------|
| A | 00 |
| B | 01 |
| C | 100 |
| D | 101 |
| E | 1100 |
| F | 1110 |
| G | 1111 |

Solution

By inspecting the codes, we see only 2 out of 4 possible 3 bit codes. Since one combination is used in 4 bit codes the remaining 3 bit code could have been used, but not. The simplest modification is to use **110** for E instead of **1100** where it seems the last bit is unnecessary anyway. Uniqueness of the codes is still preserved. In fact, no unique-code generation process would create such a code. The last bit, here, is just added after creating the Huffman code for a probability set. The very same Huffman tree that is used to generate the given code could have generated the following code

| | |
|---|------|
| A | 00 |
| B | 01 |
| C | 100 |
| D | 101 |
| E | 111 |
| F | 1100 |
| G | 1101 |

or this one

| | |
|---|------|
| A | 11 |
| B | 10 |
| C | 011 |
| D | 010 |
| E | 000 |
| F | 0011 |
| G | 0010 |

and many other depending on the assignments of the bits on the Huffman tree.

- 11.** The following waveform is to be quantized with a maximum of ± 0.5 Volts/sample error. What should be the space between quantization levels?

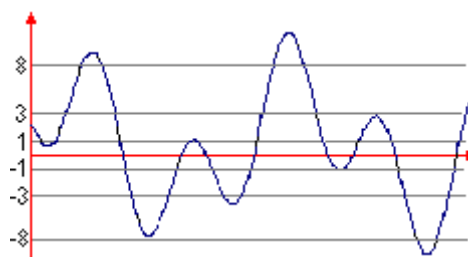

Solution

Maximum quantization error does not depend on the waveform but the spacing between quantization levels. For a maximum of ± 0.5 Volts quantization error we must have a maximum spacing of **1 V** between the levels.

49. 22.03.2008 1st Midterm

A square-wave signal $x(t) = \sum_{n=-\infty}^{\infty} \Pi\left(\frac{t-nT}{T}\right)$ AM modulates a carrier with frequency of ω_c where $\omega_c \gg \omega_0$. ω_0 is the fundamental frequency of the baseband signal and higher harmonics of $x(t)$ about ω_c can be ignored. Approximately draw the magnitude of the frequency spectrum of the modulated signal $|Y(\omega)|$.

Solution

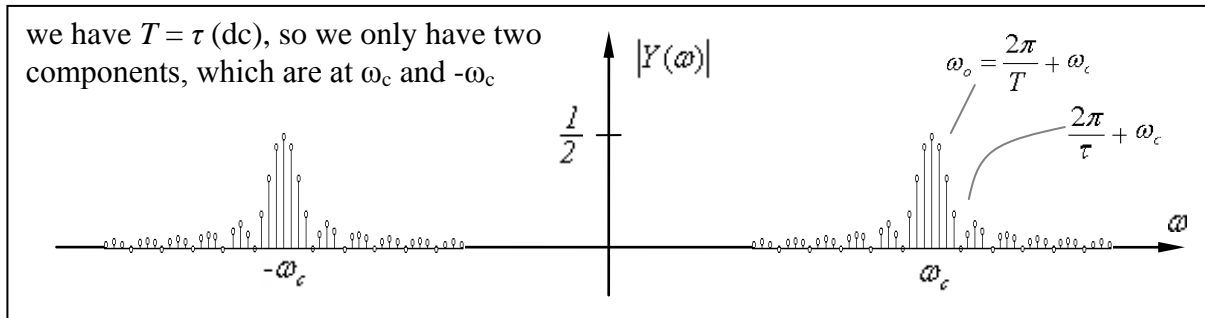

50. 22.03.2008 1st Midterm

Calculate USB-AM modulated signal for the message signal of $x(t) = 2\sin(t) - \cos(2t)$ and the carrier of $c(t) = \cos(20t)$. Draw $|Y(\omega)|$ spectrum and mark values/frequencies.

Solution

$$y_{\text{USB}}(t) = x(t) \cos(20t) - \hat{x}(t) \sin(20t) = (2\sin(t) - \cos(2t)) \cos(20t) - (-2\cos(t) - \sin(2t)) \sin(20t)$$

$$y_{\text{USB}}(t) = (2\sin(t) - \cos(2t)) \cos(20t) - (-2\cos(t) - \sin(2t)) \sin(20t)$$

$$y_{\text{USB}}(t) = 2\sin(t) \cos(20t) - \cos(2t) \cos(20t) + 2\cos(t) \sin(20t) + \sin(2t) \sin(20t)$$

$$y_{\text{USB}}(t) = -\sin(19t) + \sin(21t) - \frac{1}{2} \cos(18t) - \frac{1}{2} \cos(22t) + \sin(19t) + \sin(21t) + \frac{1}{2} \cos(18t) - \frac{1}{2} \cos(22t)$$

$$y_{\text{USB}}(t) = 2\sin(21t) - \cos(22t)$$

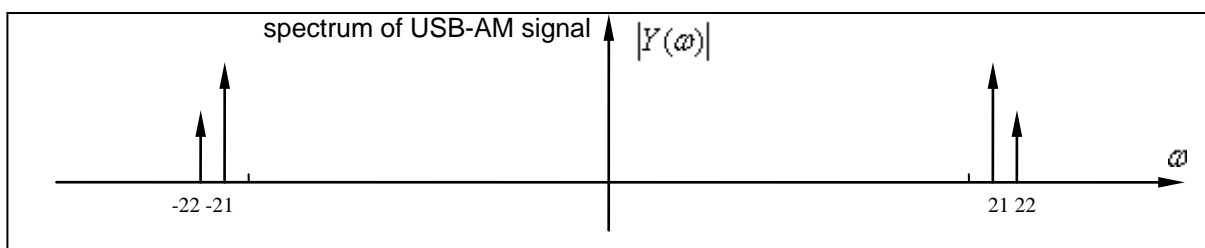

51. 22.03.2008 1st Midterm

Draw DSB-SC AM and FM (pick your own freqs.) modulated waveforms for the ternary signal given.

Solution

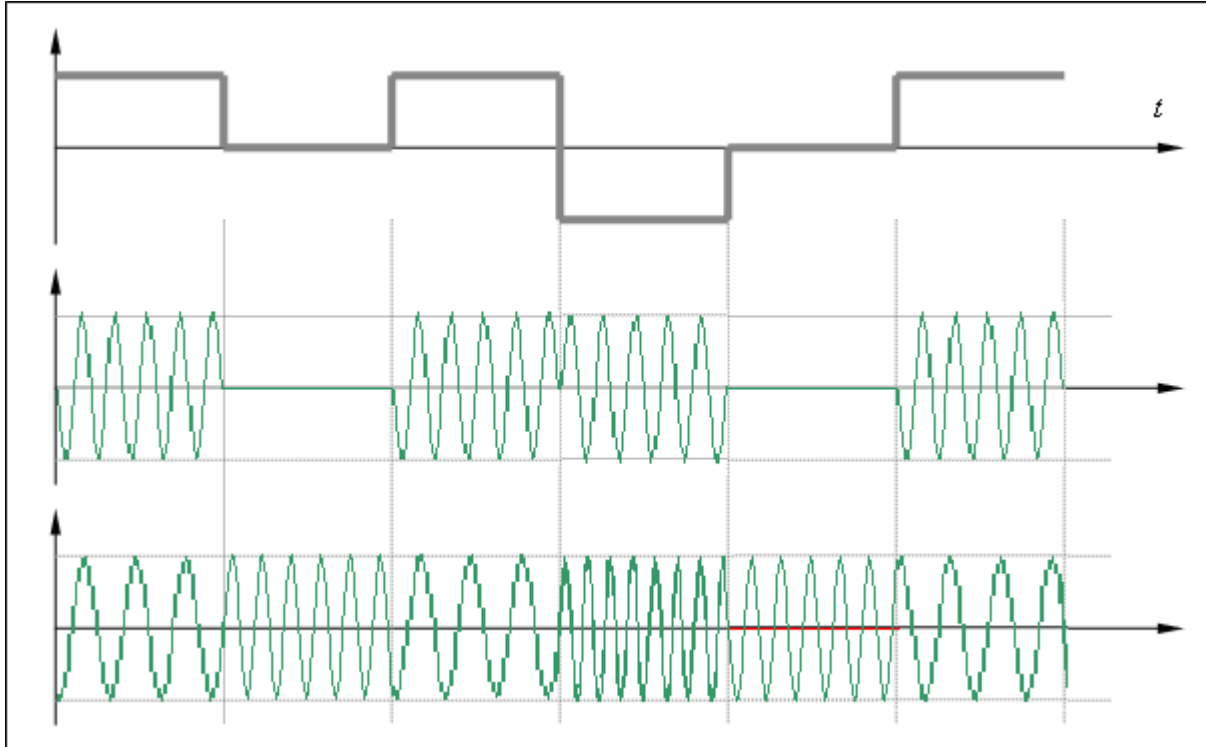

52. 22.03.2008 1st Midterm

White noise with spectral density of $N_0/2$ is at the output of the following RC circuit. What should be the value of the capacitor for output power density to be half of the input's at 10 kHz when the R is fixed to be 10k Ω ?

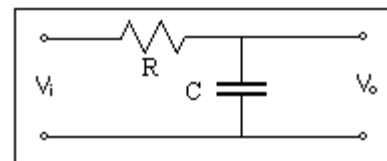

Solution

$$G_y(f) = G_n(f)|H(f)|^2 = \frac{N_0}{2} \frac{1}{1+(2\pi fRC)^2}$$

which is required to be $\frac{1}{2} \frac{N_0}{2}$. This happens when $2\pi fRC = 1$.

Using it, $C = \frac{1}{2\pi fR} = \frac{1}{2\pi \times 10 \times 10^3 \times 10 \times 10^3} = 1.6 \text{ nF}$ is found.

53. 03.05.2008 2nd Midterm (following 16 questions)

1. For a BSC, probability of transmitting 0 is $P_T(0)=0.6$ and $P_e=0.01$. What is the probability of receiving 0?

Solution

Apply total probability theorem $P_R(i) = \sum_j P_T(j)P(i | j)$

$$P_R(0) = P_T(0)P(0 | 0) + P_T(1)P(0 | 1) = 0.6 \times 0.99 + 0.4 \times 0.01 = 0.598$$

2. A binary signal with $V_0=-0.8$ and $V_1=0.9$ is under additive noise with the pdf given. Signal is ergodic and $P_0=P_1$. What would be the decision threshold for the minimum probability of erroneous reception?

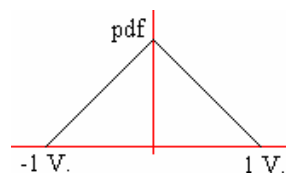

Solution

Since the pdf is symmetric the minimum probability of reception error occurs when the threshold is in the middle of two values according to ML (maximum likelihood) and according to MAP (maximum a posteriori) when $P_0=P_1$. So,

$$V_T = \frac{V_0 + V_1}{2} = 0.05$$

3. What is the type of the TV scan technique where odd numbered lines are scanned first and even numbered lines are scanned afterwards and scanning progresses as odd fields and even fields are scanned as such?

Solution

interlaced

4. What are the operations before the uniform quantization and after the reception of sampled voice signal for better distribution of quantization levels according to voice sample statistics?

Solution

companding-expanding (or compression-expansion)

5. What is the modulation technique the following signal illustrates?

Solution

There are zero crossings of the modulating signal at which the carrier phase reverses. So it is a DSB-AM (may or may not be SC)

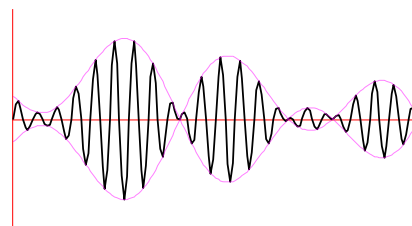

6. What is the modulation technique the following signal illustrates?

Solution

There are two amplitude levels and no phase/frequency changes. So it is an Amplitude Shift Keying (ASK) modulation

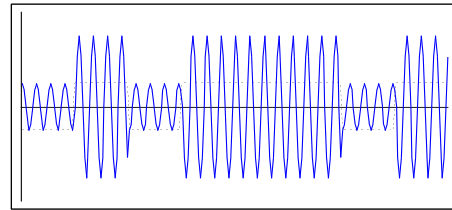

7. What is the modulation technique the following signal illustrates?

Solution

There are phase jumps but no amplitude and/or frequency changes. It is a PSK type; BPSK, QPSK, M-ary PSK or such.

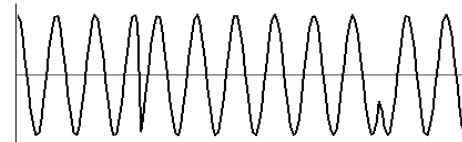

8. What is the DC component calculated by $b_o = \frac{1}{T} \int_{-T/2}^{T/2} y(t)dt$ in the periodic waveform given as $y(t) = \sin(t) + 0.5 \cos(\frac{1}{4}t) + 0.2$?

Solution

Since the time averages of sinusoidal terms are both zero (always) then the remaining term is to be used in finding average. Since the remaining term (0.2) is a constant, and time average of a constant is itself the average is seen to be 0.2. This result can directly be stated from the signal too, i.e. no evaluation is necessary.

9. What is the period of the following pulse train whose magnitude frequency spectrum is given?

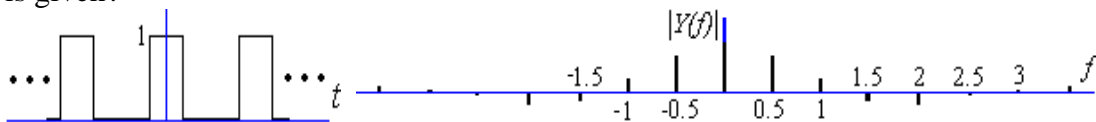

Solution

The fundamental frequency of a periodic waveform is $f_o = 1/T$ where T is the period of the waveform. We see the component at fundamental frequency in the frequency spectrum, as it is the closest one to zero frequency, to be at 0.5. Therefore $T = 1/0.5 = 2$ sn.

10. Power spectral density of an AWG Noise is given as 0.5×10^{-10} W/Hz. What is total noise power below 1 GHz?

Solution

Power equals to the area of the shaded rectangle.
 $P = 2 \times S \times BW = 2 \times 0.5 \times 10^{-10} \times 1 \times 10^9 = 0.1W$

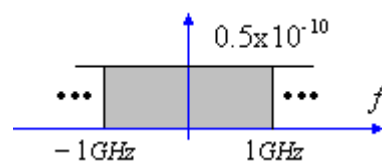

11. Symbols of a quaternary source with symbol probabilities $v=\{0.5, 0.25, 0.125, 0.125\}$ and $H(v)=1.75$ are coded with a variable length instantaneous coding (eg. Huffman). What are the most probable code length assignments?

Solution

After creating the Huffman tree we can see that the answer is $\{1,2,3,3\}$. No other meaningful assignment is possible anyway.

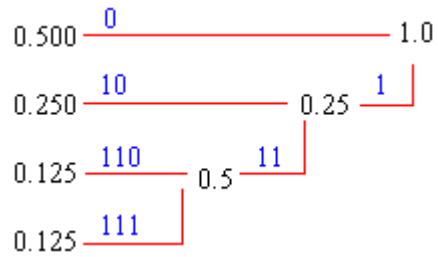

12. What would be the impulse response of a causal matched filter for the binary antipodal waveform set given as $v(t) = \begin{cases} t & 0 \leq t < T \\ -t & 0 \leq t < T \end{cases}$, for 1, for 0 ?

Solution

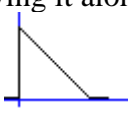
Matched filter can easily be obtained by flipping the waveform and moving it along the time axis so that its leftmost point is at $t=0$. Therefore, the answer is 

13. Which of the following subsequences would be seen in the encoded sequence of $s=\{101100011010100101111000\}$, when it is decoded? The sequence is encoded with a variable length instantaneous code $C=\{1,001,010,000,0110,0111\}$ for the symbols $S=\{a,b,c,d,e,f\}$.
 a) afec b) face c) beef d) baca e) feed f) caba

Solution

Decoding the stream with the given code and alphabet, we get $D=\{aebacabfad\}$. Only "baca" subsequence is seen in the decoded sequence among the given subsequences. So the answer is d.

14. What would be the bandwidth of the output signal of SSB-AM (USB) modulator illustrated below when the bandwidth of the baseband message signal is 3 kHz (highest freq.) and $c(t) = 2 \sin(200 \times 10^3 \pi t)$?

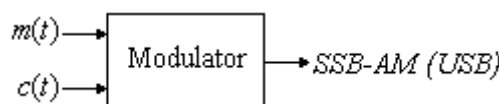

Solution

Bandwidth of SSB modulated signal does not differ from that of the original baseband signal. Therefore, the answer is 3 kHz.

15. What is the noise equivalent bandwidth of the following filter?

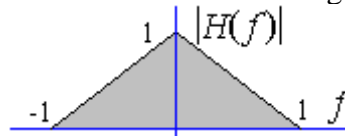

Solution

The output noise power of the filter when there is a white noise at the input is

$$P_N = 2 \int_0^1 N(1-f)^2 df = 2N \int_0^1 (1-2f+f^2) df = 2N \left[f - f^2 + \frac{f^3}{3} \right]_0^1 = 2N/3$$

whereas the output noise power of a flat filter with $H_{max} = 1$ is

$$P_E = 2 \int_0^{BW} N df = 2Nf|_0^{BW} = 2NBW .$$

Since $P_E = P_N$, then $2N/3 = 2NBW$. Thus, $BW = 1/3 = 0.3333$.

16. Two identical RF amplifiers with max gain of 2 are cascaded. Equivalent noise figure is desired to be F=6. What should be the noise figure of an individual amplifier?

Solution

Using the equivalent noise figure formulation for cascaded amplifiers

$$F = F_1 + \frac{F_2 - 1}{H_{1max}^2} + \frac{F_3 - 1}{H_{1max}^2 H_{2max}^2} + \dots + \frac{F_n - 1}{\prod_{i=1}^n H_{imax}^2} ,$$

$$6 = F_1 + \frac{F_1 - 1}{4} \text{ and } F_1 = 5 \text{ is found.}$$

54. 04.05.2008 Final Exam (following 14 questions)

1. Which one of the following is not a required property of PN-sequences?
 - a) Balance of 1s and 0s
 - b) Convolution
 - c) Runs of 0s and 1s
 - d) Correlation

2. What are the operations called when weak components of the signal (voice) that are susceptible to channel noise are amplified at the transmitter and attenuated at the receiver so that SNR is improved?
 - a) Preemphasis-Deemphasis
 - b) Amplification-Attenuation
 - c) Compression-Expansion
 - d) Companding-Expanding
 - e) Spreading-Despreading
 - f) Transmission-Reception

3. A 4-ary source has symbol probabilities of $v = \{0.12, 0.17, 0.25, 0.46\}$. What is the average information per source output, I_{avg} in bits?
 - a) 2.63
 - b) 0.547
 - c) 0.25
 - d) 0.658
 - e) 2.186
 - f) 1.817

4. Which one of the following can be the constellation diagram of DBPSK?



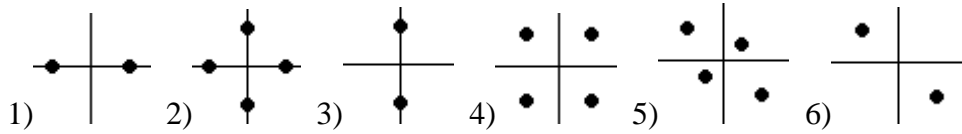

- a) 1 b) 2, 4 c) 2, 4, 5 **d) 1, 3, 6** e) 1, 3 f) 3

5. For which modulation technique, the following waveform can be a typical example?

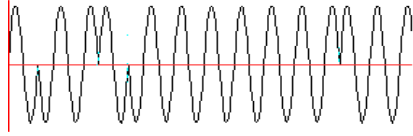

- a) FSK **b) PSK**
c) FM d) ASK
e) QAM f) PCM

6. For which modulation technique, the following waveform can be a typical example?

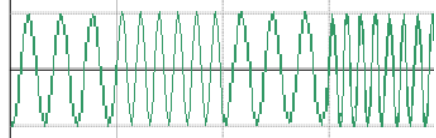

- a) FSK** b) PSK
c) FM d) ASK
e) QAM f) PCM

7. For which modulation technique, the following waveform can be a typical example?

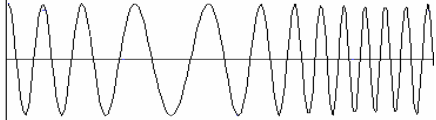

- a) FSK b) PSK
c) FM d) ASK
e) QAM f) PCM

8. For which modulation technique, the following waveform can be a typical example?

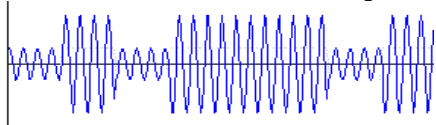

- a) FSK b) PSK
c) FM d) QAM
e) ASK f) PCM

9. A sawtooth signal with zero mean is given. From the scope (shown below) T_1 , T_2 and T_3 are measured as 1, 2 and 3 ms respectively. What would be the W distance shown below, in Hz, in the frequency spectrum of the waveform?

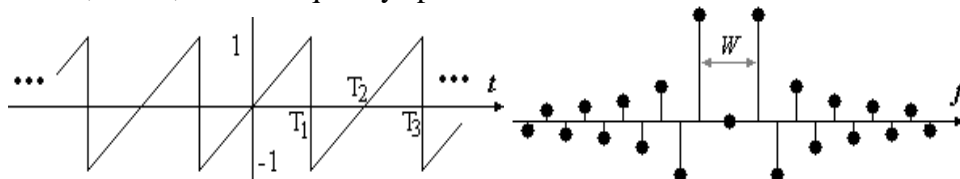

- a) 2 Hz b) 333 Hz **c) 1 kHz** d) 0.5 kHz e) 2 kHz f) 666 Hz

10. An antipodal PCM signal (+1, -1 V) is under strong noise with uniform pdf ($0 < V_{in} < 2$). Within each bit interval, 2 samples (sufficiently apart) are taken from input (V_{in}), their average is calculated and decision is made accordingly with decision threshold being 0V. What is the probability of error per received bit?

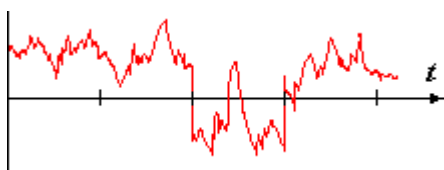

- a) 0.04 b) 1
c) 0.1 d) 0.5
e) 0.125 f) 0.25

11. A binary channel with symmetric error probability has probability of error $P_e=0.01$. What is the probability of receiving zero (0) when probability of sending one (1) is 0.6?
 a) 0.598 b) 0.4 c) 0.396 d) 0.594 e) 0.406 **f) 0.402**

12. The component shown with an arrow on the TV signal in the left figure is used in conjunction with one of the components shown in the frequency spectrum on the right. Which one is it?

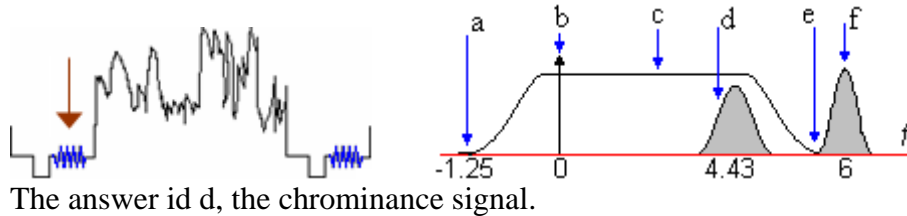

13. What should be the relation between R and C in the given circuit for the value of output power spectral density function to be half of the input psd value at $\omega_c = 1$?

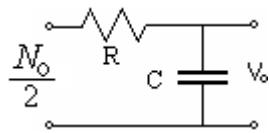

- a) $C = \omega_c R$ b) $C = \omega_c R^2$
 c) $C=R$ **d) $C=1/R$**
 e) $C = \omega_c / R$ f) $C=1-R$

14. Which one of the following can be the magnitude Fourier spectrum of a real signal that takes finite values between $t_0=0$ and $t_1=1$, and zero elsewhere?

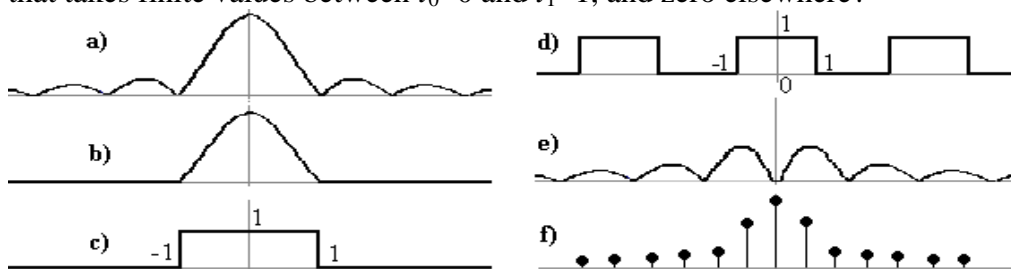

The answer is a.

55. 24.03.2009 1st Midterm (following 15 questions)

1. Which of the following real filters is most likely to have maximum output power among all when their input is an impulse at $t=0$.

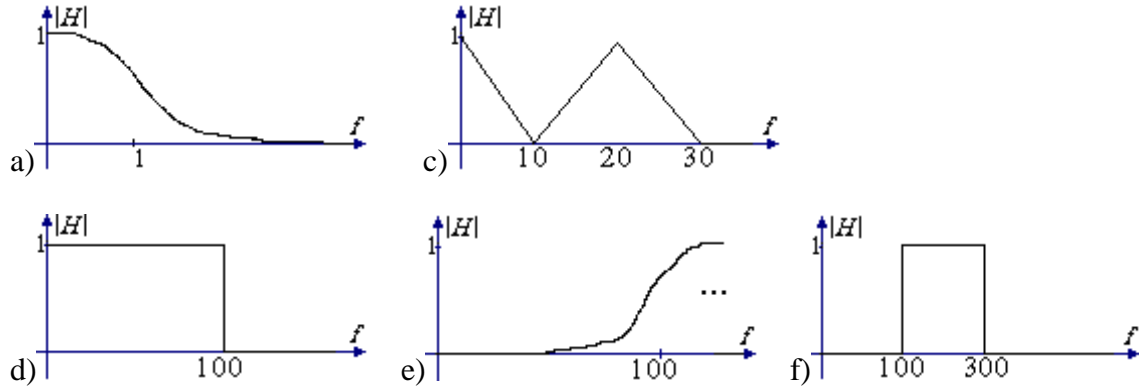

Solution

All but HPF given in e) has finite area underneath the curve. The answer is clearly e).

2. Which of the following is the power spectrum of $y(t) = \sin(t) + 2\cos(t) + \cos(2t + \pi/4)$?

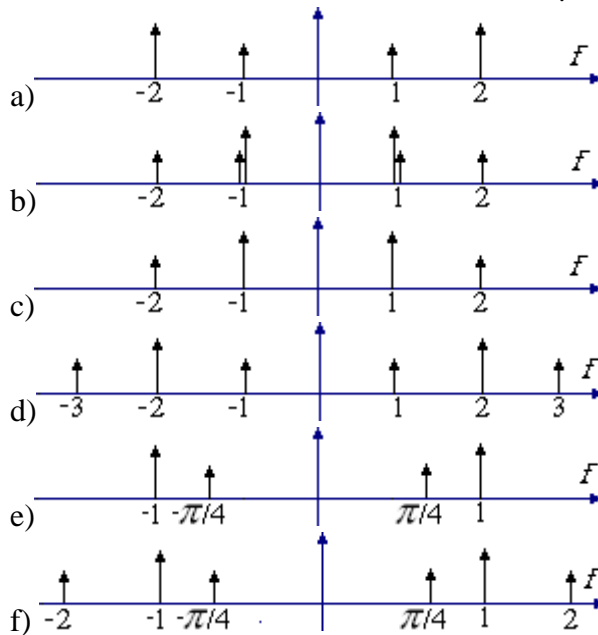

Solution

Linear weighted sums of sinusoids of the same frequency give us a sinusoid with the same frequency. It will have a phase determined by the phases and magnitudes of the original sinusoids. We can find the phase and magnitude of it by using phasor summation. Since, in our case, $\sin(t)$ and $\cos(t)$ have 90° phase angle between them, the magnitude shall be $\sqrt{a^2 + b^2}$ where a and b are the magnitudes of sinusoids. This will make the magnitude of the summed sinusoid greater than 1. Since we would

have only 2 sinusoids in our final signal and the other one (with the freq. of 2) has a magnitude of 1, our answer shall be c).

3. Powers of two periodic signals $x_1(t)$ and $x_2(t)$ are 3 and 4 Watts respectively. Which of the following can be the maximum possible energy delivered in every 2 seconds intervals from the source of $x_1(t) + x_2(t)$?
- a) 15 b) 14 c) 10 d) 7 e) 50 f) 25

Solution

Power is, by definition, energy delivered in one unit time. The question asks the energy delivered in 2 unit time. The maximum deliverable energy is $3+4=7$ per unit time. In 2 unit time, it will deliver 14. So the answer is b).

4. Which of the following is most-likely the FSK signal for a ternary (3-level) message?

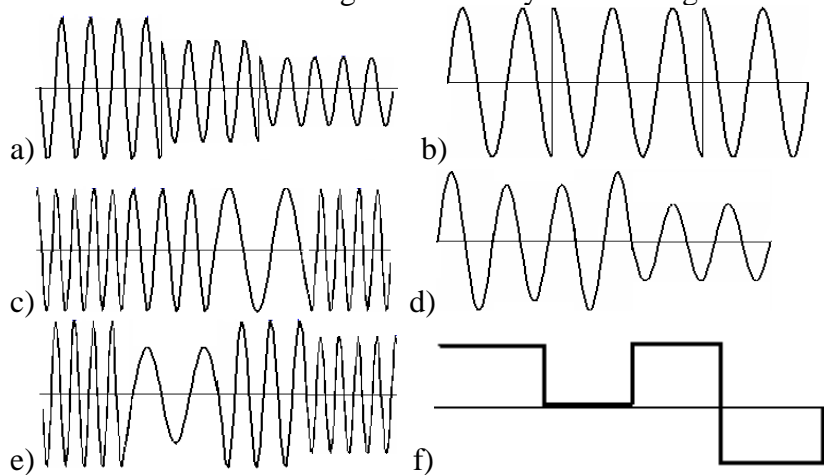

Solution

In FSK, like regular FM, signal amplitude is not varied, nor do we expect sudden phase changes/jumps. For our ternary case, we should have 3 distinct frequency and no amplitude change in the signal. This points to answer c).

5. What is the output of the following block circuit?

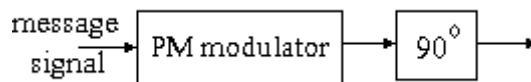

- a) tone signal. b) FM signal c) 90° shifted message signal
 d) message signal e) PM signal f) 90° modulated signal

Solution

PM modulator output is phase shifted by 90°, but still is a PM signal. The other answers are not meaningful anyway.

6. What would be the spectrum of the modulated signal if DSB-SC-AM modulation is performed with the following message and carrier signals?

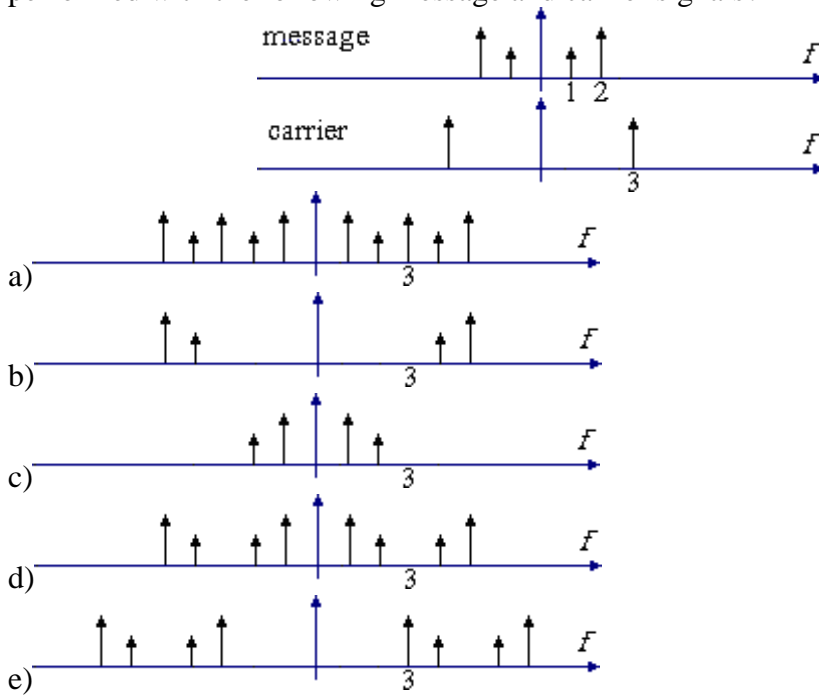

Solution

By the modulation property of Fourier Transform, we expect that the message signal is replicated around the carrier frequency. We would not have any component at the carrier frequency unless the message signal has DC component or we explicitly add carrier later. Therefore, the answer is d).

7. After modulating a carrier signal with $x(t)$, $y(t)$ is obtained. What would one get if a diode+RC envelope detector used at the receiver?

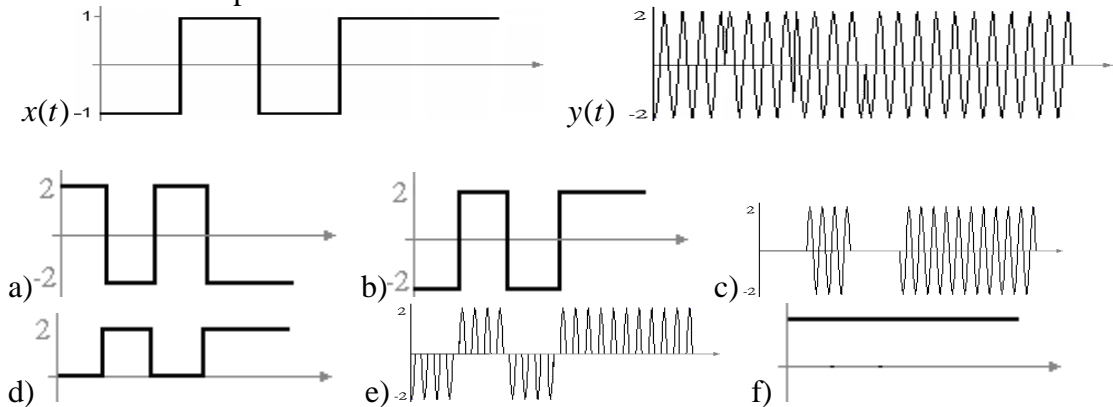

Solution

A diode+RC envelope detector extracts the envelope as the name says. Our modulated signal has a constant envelope. Therefore, the answer is f)

8. In the following block circuit, the inputs are $\cos(\omega_c t)$ and USB-AM signal generated with carrier $\cos(\omega_c t)$ and a tone signal $\cos(\omega_x t)$. The cutoff frequency of the LPF is ω_c . What is the output?

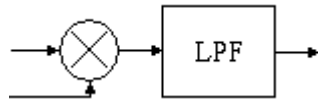

- a) $A\cos(\omega_x t)$ b) $\cos(\omega_x t)\sin(\omega_x t)$ c) $\cos(\omega_x t)\sin(2\omega_c t)$
d) $\frac{1}{2}\sin(\omega_x t)\sin(2\omega_c t)$ e) A f) $\cos((\omega_c - \omega_x)t)$

Solution

SSB-AM demodulators are the same as synchronous AM demodulators. However, we cannot use envelope detectors for SSB-AM signals as we did in conventional AM case. The given block circuit is a synchronous demodulator. Therefore, we expect the output be the message signal. As mentioned in the question, the message signal is a tone signal, $\cos(\omega_x t)$. This makes our answer a). (this was a homework)

9. Name the components of composite video signal that occurs during horizontal blanking.

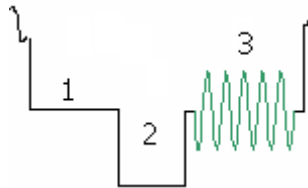

- a) vertical sync., vertical blanking, deflection signal
b) grid signal, horizontal pulse, horizontal scan
c) NTSC signal, PAL signal, SECAM signal
d) color sync., bw sync., scan sync.
e) front porch, horiz. sync, color burst
f) back porch, horiz. blanking, osc. signal

Solution

The answer is e). An answer of "front porch, horizontal sync., back porch" would also be an answer, but it is not in the choices.

10. Given the frequency spectrum, identify the components of the TV signal.

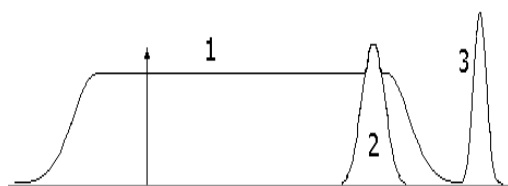

- a) chrominance, luminance, color
b) luminance, chrominance, audio
c) audio, video, color,
d) luminance, audio, color
e) carrier, luminance, audio
f) color, chrominance, luminance

Solution

The answer is b)



11. Name the modulation techniques used in color broadcast TV-signal.
 a) AM, FM, PM b) VSB, QAM, FM c) VSM, PM, AM
 d) DSB-AM, AM, PSK e) QAM, SSB, FM f) FM, ASK, QFM

Solution

The answer is b). VSB is used for luminance or luma. Color components, U and V (named together as chrominance or chroma) are transmitted using QAM. The audio component is a regular stereo FM.

12. What is the scanning method in which odd and even numbered TV-lines are scanned separately, that is, odd lines are scanned first and even lines are scanned afterwards and so on?
 a) progressive b) odd-even scan c) field scan
 d) two fields e) seperable scan f) interlaced

Solution

Since odd and even numbered lines are "interlaced" the technique is called as so. It could have been called with many other names but here we are.

13. What is the power of the component at 0 frequency for periodic (T) signal given?

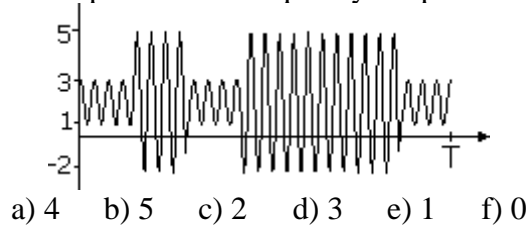

Solution

DC component (time- average value) of the given signal seems to be 2. One could use the integral formula of $P_x = \frac{1}{T} \int_{\alpha}^{\alpha+T_o} |x(t)|^2 dt$ to calculate power. Here it is assumed that $x(t) = y(t) + c$ and $y(t)$ has zero mean. In addition, we know that a carrier modulated with a train consisting of rectangular pulses has a power spectra of two *sincs* one of which is centered at carrier frequency and the other is the mirror of it at negative f axis. Here we have another assumption that those *sincs* do not add up to a meaningful value at zero frequency, considering that the carrier freq is much higher than the bandwidth of the main lobe of the *sincs*. What remains at zero frequency is the added DC and the power of it is just the magnitude-squared value. Therefore, the answer is a).

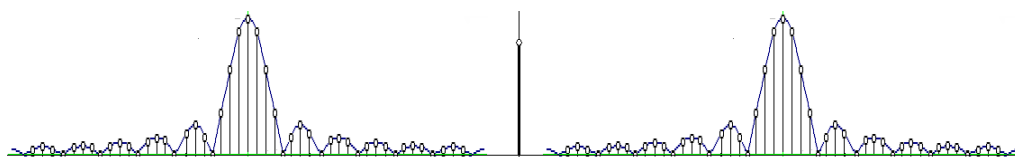

14. Determine T for the signal energy to be 27.

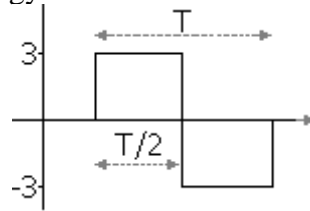

- a) 2 b) 9 c) $\sqrt{3\pi}$ d) 3 e) 3π f) not possible

Solution

Using $E_x = \int_{-\infty}^{\infty} |x(t)|^2 dt = \int_0^T 9 dt = 9T = 27$, we find that $T=3$ and mark answer d).

15. A single period of $x(t)$ is shown. What is the most-likely analytical expression for it?

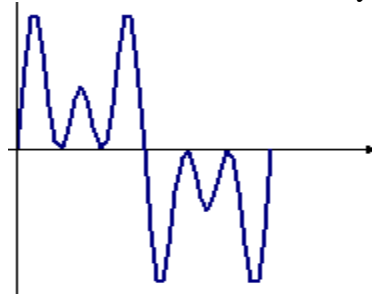

- a) $\cos(t) + \sin(2t) + \cos(3t)$ b) $\sin(t) + \sin(2t) + \sin(3t)$ c) $\sin(t) + \sin(3t) + \sin(5t)$
 d) $2\sin(t) + \sin(2t) + \frac{1}{2}\sin(3t)$ e) $2\sin(t) + \cos(3t) + \frac{1}{2}\sin(3t)$
 f) $\cos(3t) + \cos(t) + \sin(6t)$

Solution

This is an odd signal. All sub-signals of odd signals are necessarily odd. For this reason, none of the choices a), e) and f) can be an answer. Perfect even symmetry within half period is a hint that the signal contains no even harmonics. This eliminates the choices b) and d), leaving us with the answer c)

56. 28.04.2009 2nd Midterm (following 14 questions)

1. Which one of the following can be the constellation diagram of a DBPSK system?

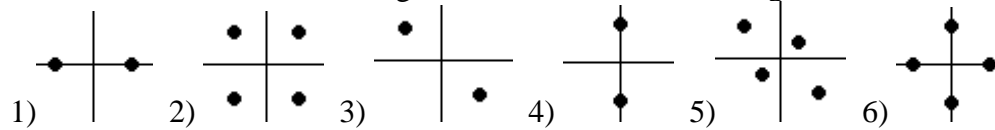

Solution

BPSK has only two points on constellation diagram representing 0 and 1. Being differential does not change that. So the answer is (1, 3, 4).

2. What are the names of operations done in voice systems in order to obtain non-uniform quantization levels in the transmitter side and the reverse operation in the receiver side?

Solution

The answer is "Companding / Expanding"

3. For which modulation technique, the following waveform can be a typical example?

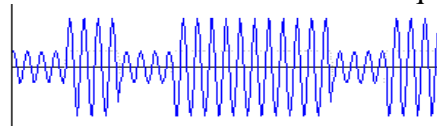

- a) ASK
- b) PSK
- c) FSK
- d) QAM
- e) PCM
- f) FM

4. What is the probability of receiving 0 on a Binary-Symmetric-Channel where the probability of transmitting 0 is 0.4 and channel error probability is 0.01 ?

Solution

Using the total probability theorem $P_o(0) = P_i(0)P(0|0) + P_i(1)P(0|1)$ where $P_i(0) = 0.4$, $P_i(1) = 0.6$, $P(0|1) = 0.01$ and $P(0|0) = 0.99$ we calculate that

$$P_o(0) = 0.4 \times 0.99 + 0.6 \times 0.01 = 0.402$$

5. On a Binary-Symmetric-Channel, the probabilities of transmitting 0 and 1 are equal and these levels are represented by 0 V and 0.8 V respectively. What is the probability of error when the decision threshold on the receiver is set to 0.4 V and the channel is under additive noise whose pdf is given below?

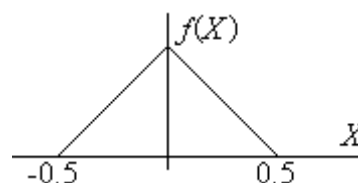

Solution

Probability of making a decision error when 0 is transmitted (but erroneously decided that it is a 1 since it is above the threshold 0.4) is illustrated with a gray area shown in the figure below

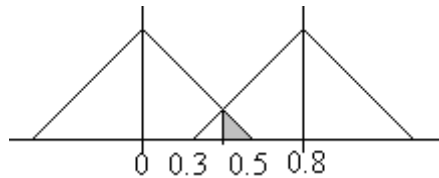

The area is $\int_{0.4}^{0.5} (2-4x)dx = 0.02$. Since probabilities of transmitting 0 and 1 are equal and the pdf is symmetric, we can conclude that it is also the probability of making an error without a need to calculate the error when 1 is transmitted.

6. Power spectral density of a signal at the input of the following circuit is given as $S_i(\omega) = 4/(1 + \omega^2)$. What is the output power spectral density?

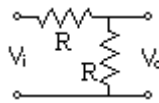

Solution

Our system is just a voltage divider with the transfer function of $H(\omega) = 0.5$. Output power spectral density is then $S_o(\omega) = S_i(\omega)|H(\omega)|^2 = \frac{1}{1 + \omega^2}$

7. Three amplifiers A1, A2 and A3 with gain and noise figures given as (2, 4), (2.5, 3.2) and (1.2, 1) respectively are to be cascaded. What would be your choice of cascading order for the best SNR at the output?

Solution

Starting to try with the best possible solution, the equivalent noise figure of $A_3A_2A_1$ is found that

$$F_{321} = F_3 + \frac{F_2 - 1}{H_{3\max}^2} + \frac{F_1 - 1}{H_{3\max}^2 H_{2\max}^2}, \quad F_{321} = 1 + \frac{2.2}{1.44} + \frac{3}{1.44 \times 10.24} = 2.73$$

which is smaller than the individual noise figures of A_1 and A_2 . Therefore, we do not need to try out a combination starting with A_1 or A_2 . However, we can check out $A_3A_1A_2$ possibility.

$$F_{312} = 1 + \frac{3}{1.44} + \frac{2.2}{1.44 \times 16} = 3.18$$

and see that it is worst than the first choice above. We conclude that $A_3A_2A_1$ should be our choice for best SNR at the output.

8. What is the expected value of the ergodic signal given as $x(t) = \sin^2(2t) + \cos(t + \pi/2)$?

Solution

For ergodic signals, we know that the expected value equals to the time average that in turn equals to the DC value. Hence, we see from $x(t) = \frac{1}{2} - \frac{1}{2}\cos(4t) + \cos(t + \pi/2)$ that the DC value is 0.5. Therefore, the answer is 0.5.

9. What is the minimum sampling frequency in order for complete recovery of the signal whose frequency spectrum is given ?

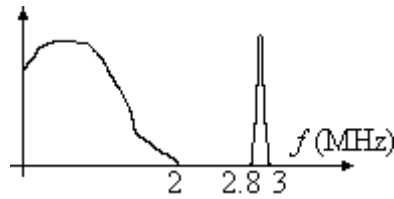

Solution

Since our signal is baseband, the answer should be a frequency higher than the twice of the highest frequency in the signal. That is, $f_s > 6\text{MHz}$.

10. What is the constellation diagram of the PSK system that generates I and Q waveforms given below for the input stream of "1001001101"?

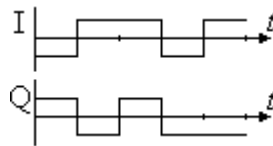

Solution

Carefully placing the phasor points at the constellation diagram and putting the input bit pairs next to them, we find that our answer is as shown on the right.

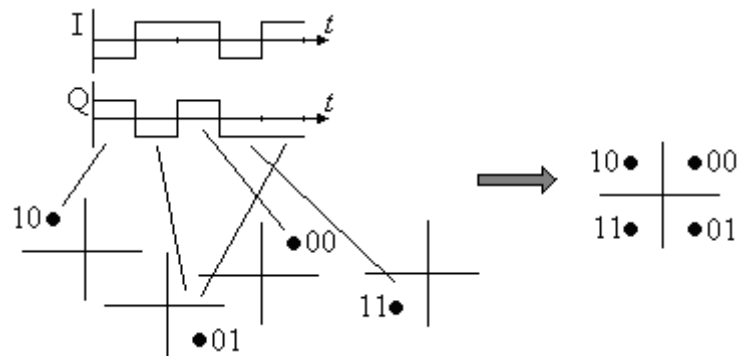

11. For an M-ary PSK system where M is 2, 4, 8, 16,...etc, what is the number of changes on I/Q signals per input bit duration?

Solution

Usually number of bits per symbol comes up. But number of changes per bit is just the inverse of it. Number of bits per symbol is $\log_2 M$. The inverse of it, the number of changes per bit is then $1/\log_2 M = \log_M 2$.

12. For which modulation technique, the following waveform can be a typical example?

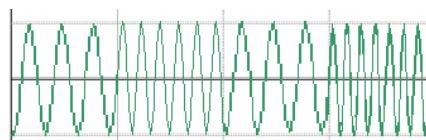

Solution

The waveform has sudden changes at the frequency and no change in amplitude. It can be a typical example of FSK.

13. For which modulation technique, the following waveform can be a typical example?

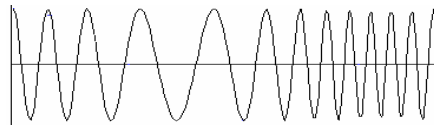

Solution

The waveform has slow changes in frequency and no change in amplitude. Therefore, it can be a typical illustration of FM with exaggerated frequency deviation. Waveform can also be used to illustrate PM, since these two are closely related and for continuous message signals it is very hard to tell them apart.

14. An additive noise with uniform pdf between -1 and 1 affects a ternary signal with transmission values of -A, 0 and A of equal probabilities. What is the minimum value of A for channel error to be minimum ?

Solution

The following figure illustrates a ternary system with additive noise pdfs for two cases

- a) Voltage levels are sufficiently apart so that for a uniform noise pdfs and decision threshold selected right in the middle of the signal voltage levels, the decision error is zero.
- b) Voltage levels are not sufficiently apart, so that even for a threshold selected right at the halfway between the signal voltage levels, probability of error is not zero.

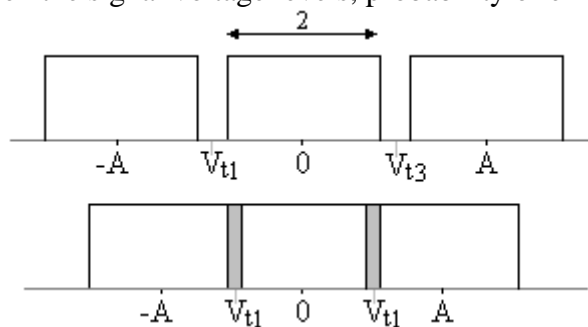

The minimum limit for A is 2 where the rectangles representing pdfs are just touching. The threshold voltages should be selected as 1 and -1 in that case.

57. 10.06.2009 Final Exam (following 16 questions)

1. Input to the LTI system below is white Gaussian noise with mean $m=1$ and variance $\sigma = 1$. What is the mean value of the output signal?

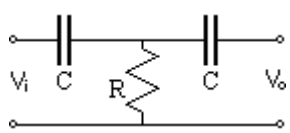

- a) $\frac{1}{1 + \pi^2 R^2 C^2}$ b) $\frac{1}{RC}$ c) 0
 d) 1 e) RC f) none of the given

Solution

As there are serial capacitors on the signal path and no other source, mean value (DC value) is zero.

2. What is the magnitude spectrum of $y(t) = (1 + \sin(t) + 2\cos(2t))\sin(10t)$?

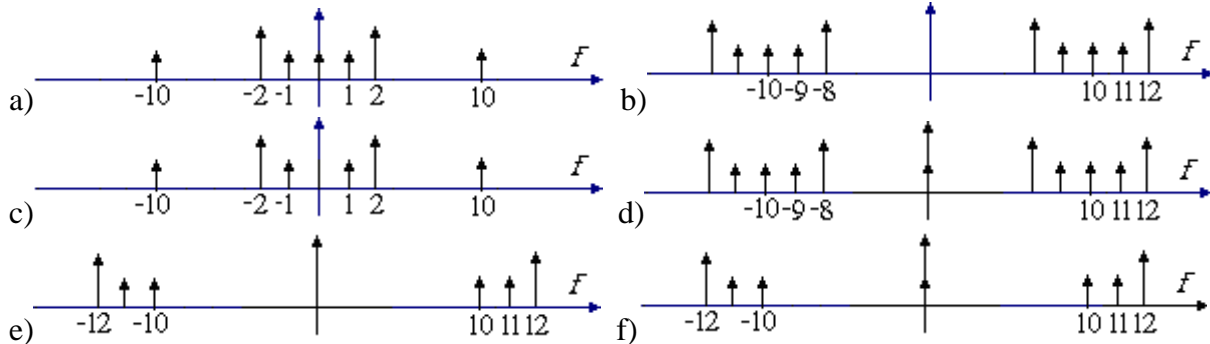

Solution

We see that $1 + \sin(t) + 2\cos(2t)$ signal AM modulates $\sin(10t)$ carrier. According to modulation property of FT, the output should be the sum of copies of baseband spectrum located at \pm carrier frequencies. So the answer is b.

3. Message signal $x(t)$ modulates a carrier with PSK and $y(t)$ is obtained. At the receiver a diode+RC envelope detector is used. What would be the output of the detector?

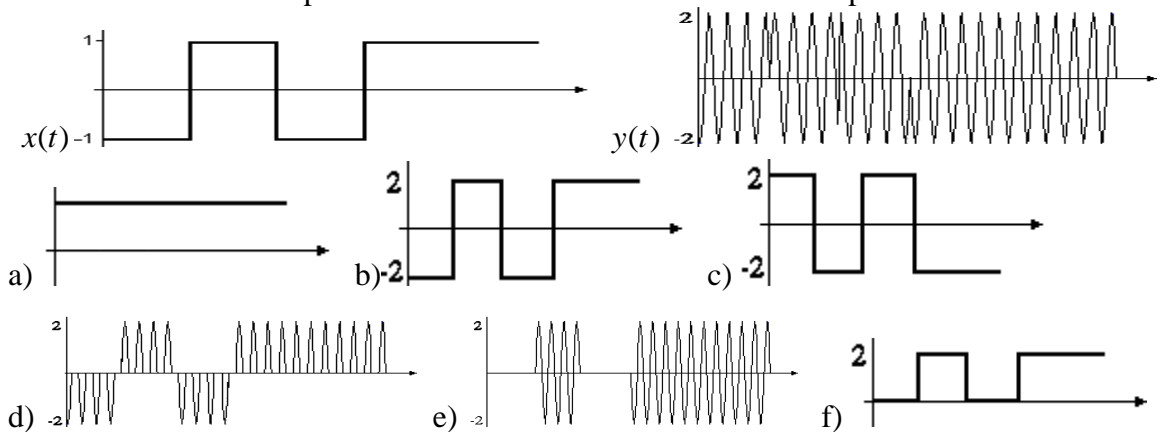

Solution

A diode+RC envelope detector extracts the envelope as the name says. Our modulated signal has a constant envelope. Therefore, the answer is a)

4. What is the energy and power contained in the given signal?

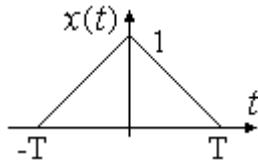

- a) $E = \infty, P = 3T/2$ b) $E = 3T/2, P = 0$ c) $E = 0, P = 3T$
 d) $E = 2T/3, P = 0$ e) $E = \infty, P = 2T$ f) $E = T, P = T^2$

Solution

$$E = \int_{-\infty}^{\infty} |x(t)|^2 dt = 2 \int_{-T}^0 \left| \frac{t}{T} + 1 \right|^2 dt = 2 \left[\frac{t^3}{3T^2} + \frac{t^2}{T} + t \right]_{-T}^0 = \frac{2T}{3}$$

Energy is found to be finite, therefore the power is zero. The answer, then, is d.

5. How many bits are transmitted per phase shift in a QPSK system?

- a) 1 b) 3 c) 1.5 d) 4 e) 0.707 f) 2

Solution

In M-ary PSK communication $M = 2^r$, where r is the number of bits represented by one constellation point. Since M is 4, r is 2.

6. Which of the following is most-likely the ASK signal for a ternary (3-level) message?

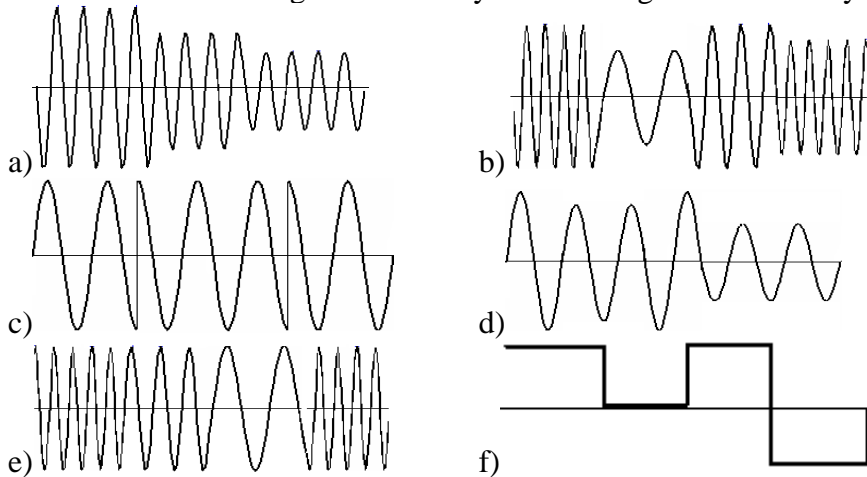

Solution

In ASK, like regular AM, signal frequency is not varied, nor do we expect phase changes/jumps. For our ternary case, we should have 3 distinct amplitudes and no frequency change in the signal. This points to answer a).



7. Which of the following is really a property of PN-sequences?
- a) The number of zeros is even b) Number of zeros and ones differ by at most one. c) The length of sequence is an odd integer d) The autocorrelation is 2 at maximum. e) Half the runs are two chip long f) Generator of the sequence has odd number of taps.

Solution

Among the properties of *run*, *correlation* and *balance*, we see only the balance property here in b, which is the answer

8. Given the Huffman tree below, what is the original uncompressed data string represented by 010011011110?

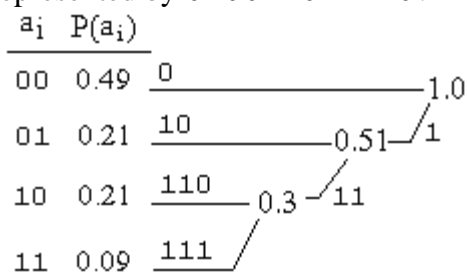

- a) 100111101111110 b) 001010011001
 c) 000100101101 d) 110010101001
 e) 111110100 f) 010110111

Solution

Decoding a unique variable length code starts from the first (leftmost) bit and continues as bits appended until a match is found in the code. Leftmost bit is 0. From the table we find that it is the code for "00". Second bit is 1 which has no match in the codec. But appending the third bit, which is 0, we get 10, and see that it is in the code and represents "01". Our decoded stream becomes "0001..." so far. We do not need to decode entire string, since there is only one answer that starts with "0001" which is c.

9. Name the components pointed at on a portion of color video signal below.

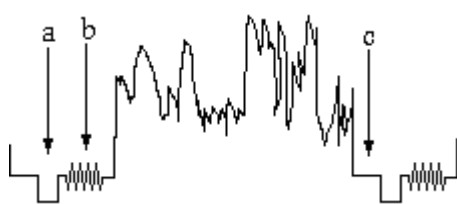

- a) sound, color sync, vsb b) horiz. sync, backporch, video c) vert..sync, front porch, rgb
 d) sync, line scan, audio e) horiz. sync, color burst, front porch f) color burst, chroma, luminance

Solution

The answer is e) horizontal sync. pulse, color burst signal and blanking space before the synch pulse, named as front porch.

10. A binary signal with two equally probable values of $\pm A$ is under additive noise whose pdf is given below. What is the probability of decision error when $A=0.85$ and threshold value is selected to be 0?

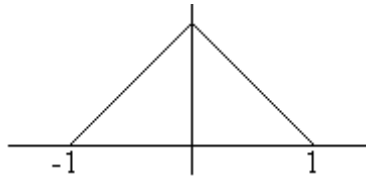

- a) 0.015 b) 0.0225 c) 0.075
d) 0.15 e) 0.01 f) 0.01125

Solution

The probabilities of decision errors are shown by the shaded triangular areas below as the decision threshold is 0.

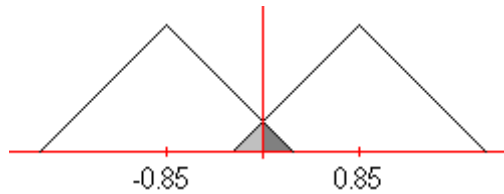

Area of a single triangle is.

$$p_e = 0.15 \times 0.15 / 2 = 0.01125$$

In the cases where the distribution is not symmetric and the probabilities of occurrences binary values are unequal, we would use the total probability theorem.

$$p_e = p(0)p(1|0) + p(1)p(0|1)$$

Since in our case $p(0) = p(1) = 0.5$ and $p(1|0) = p(0|1) = \text{areas_shown}$ we can directly state that total probability is the probability we have already found. The answer is 0.01125.

11. A channel has non-flat noise spectral density. We would like to protect message signal components at frequencies where noise is strong, thus improve SNR, using filters before transmission and after reception. What is the operation that these filters do?
- a) improve-protect b) amplify-attenuate c) emphasize-deemphasize
d) equalize-flatten e) compression-expansion f) companding-expanding

Solution

The answer is c) *emphasize-deemphasize*

12. What is the matched-filter response for the signal given?

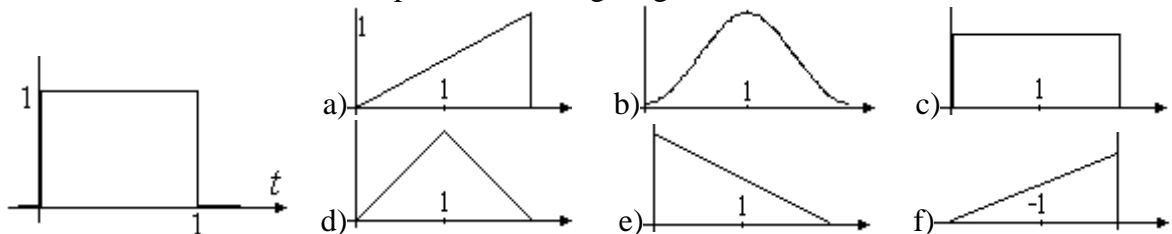

Solution

Matched filter can be found by flipping the signal along t axis and sliding it to the right until all non-zero parts are in positive-time section so that the filter is causal. When we do that, we find a filter shaped as rectangular pulse again. The filter response can be calculated by convolving input pulse with the filter pulse. Convolution of two rectangular pulses is a triangular pulse shown in answer d.

13. Two identical amplifiers with gains of $H^2 = 10$ and noise figures of $F = 4$ are to be cascaded. What would be the noise figure of entire amplifier?
 a) 8 b) 0.8 c) 4 d) 0.3 e) 4.3 f) 4.4

Solution

Applying the Fries' formula for 2 stages,

$$F = F_1 + \frac{F_2 - 1}{H_{1\max}^2} = 4 + \frac{4 - 1}{10} = 4.3$$

14. A band-limited signal with psd shown below is fed into a filter $|H(\omega)| = \begin{cases} 1, & \omega < 5 \\ \sqrt{2} & \omega \geq 5 \end{cases}$.

What is the output power spectral density?

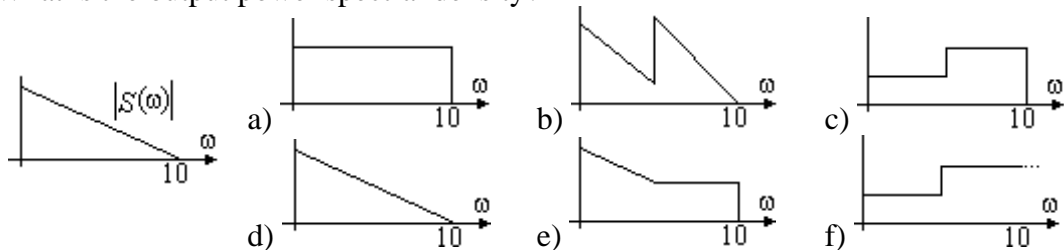

Solution

$$S_o(\omega) = S_i(\omega)|H(\omega)|^2 = \begin{cases} S_i(\omega) & , \omega < 5 \\ 2S_i(\omega) & , \omega \geq 5 \end{cases}$$

This will resolve to the psd shown in b.

15. Magnitude frequency spectrum of a real ergodic signal is given as shown. What is the time-average of the signal?



Solution

Time-average equals to the DC value of the signal. From the given spectrum, DC value is seen to be zero. Therefore, the answer is a) 0.

16. White noise with uniform spectral power density of 1 is at the input of a filter

$$|H(f)| = \begin{cases} 2, & 1 < f < 2 \\ 0, & \text{otherwise} \end{cases}. \text{ What is the output noise power?}$$

- a) 2π b) $\sqrt{2}$ c) 1 d) 4 e) 2 f) 8

Solution

$$S_o(f) = S_i(f)|H(f)|^2 \text{ and } P_o = \int_{-\infty}^{\infty} S_o(f)df = \int_1^2 4df = 4$$



58. 23.03.2010 1st Midterm Exam (following 12 questions)

1. Name the modulation techniques the following waveforms best represent (in the order).

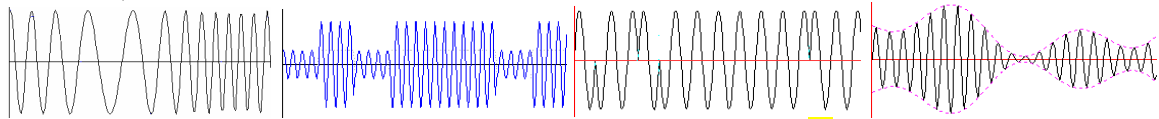

- a) AM, FM, PM, PSK b) PM, PSK, QSK, DSB **c) FM, ASK, PSK, AM**
 d) FM, QPSK, ASK, QAM e) QPM, SSB, PSK, AM

2. What is the noise power at the output of the filter $|H(f)| = \begin{cases} 2, & 1 < |f| < 2 \\ 0, & \text{otherwise} \end{cases}$ when input

is white noise of $|X(f)| = 1$.

- a) 8** b) 6 c) 4 d) 2 e) π

3. What would be the spectrum of the modulated signal if SSB-SC-AM (USB) modulation is performed with the following message and carrier signals?

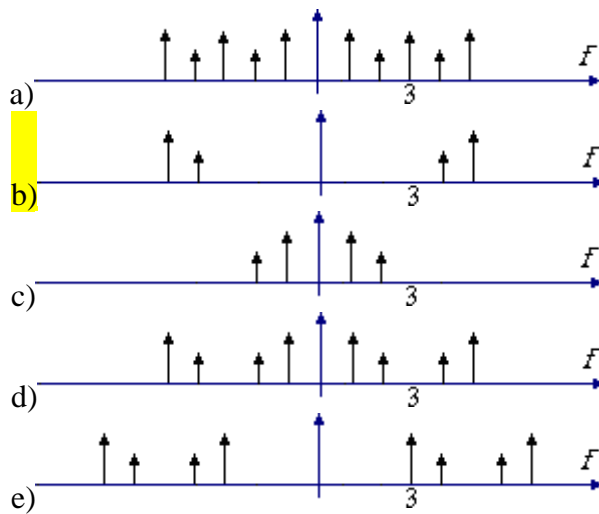
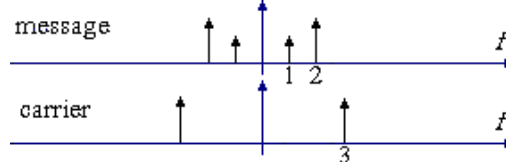

4. Name the modulation techniques used in TV signal to carry luminance, color and sound (in that order).

- a) FM,AM,PSK b) QPSK,FM,VSB c) FM,AM,PM **d) VSB,QAM,FM**
 e) VSB,SSB,ASK

5. Power of the following signal (with period T) is G. What is the value of A?

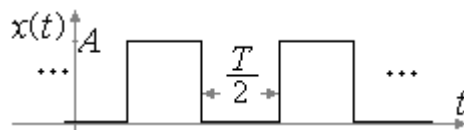

- a) A^2 b) $2G^2$ c) $G/2$
 d) \sqrt{A} **e) $\sqrt{2G}$**

6. What is the scanning method in which odd and even numbered TV-lines are scanned separately, that is, odd lines are scanned first and even lines are scanned afterwards and so on.?

- a) progressive b) odd-even scan c) field scan **d) interlaced** e) separable scan

7. What is the period of the signal whose magnitude spectrum is given?

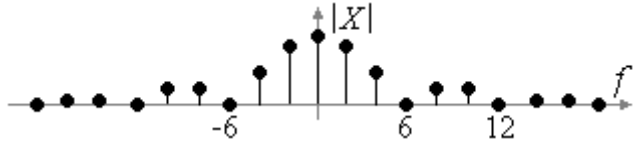

- a) 1/2** b) 1 c) 1/6
d) 1/3 e) $\pi/2$

8. Magnitude frequency spectrum of a signal consisting of two sinusoidal is given. What is the period of the signal?

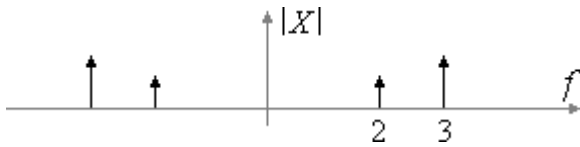

- a) 1/2 **b) 1** c) 1/3
d) 3 e) 2

9. What would output power spectral density of the following LTI circuit be like when input is Gaussian white noise?

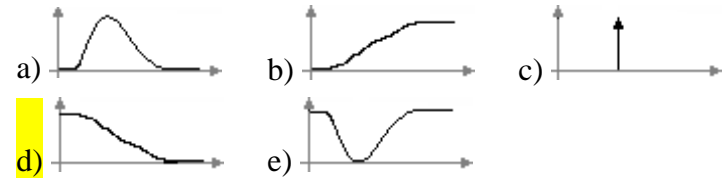
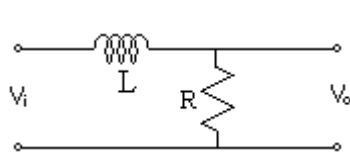

d)

10. Stereo-FM uses an approach illustrated below. What are the outputs $y(t)$ and $z(t)$?

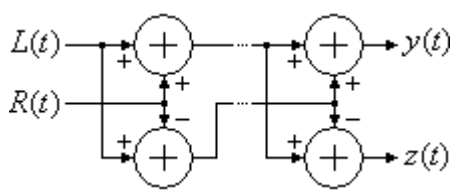

- a) $\cos(\omega_c t)$, $x(t)$ b) PM, FM c) USB, LSB
d) $\hat{R}(t)$, $\hat{L}(t)$ **e) $\hat{L}(t)$, $\hat{R}(t)$**

11. Compared to NTSC, PAL TV system is designed to alleviate the effects of phase-shifts. What do phase-shifts cause?

- a) loss of sync **b) color-shifts** c) voice-artifacts
d) blank lines e) picture shifts

12. Energy spectral density of a signal is given as $S(f) = \begin{cases} 1-|f|, & 0 < |f| < 1 \\ 0, & \text{otherwise} \end{cases}$. What is the

total energy of the signal?

- a) 4 b) 14/3 **c) 1** d) 2 e) 8

59. 27.04.2010 2nd Midterm Exam (following 12 questions)

1. X is a uniform random variable ranging between -1 and +1 and modeling the sample values taken from a periodic waveform. Which of the following is the waveform that gives such a distribution?

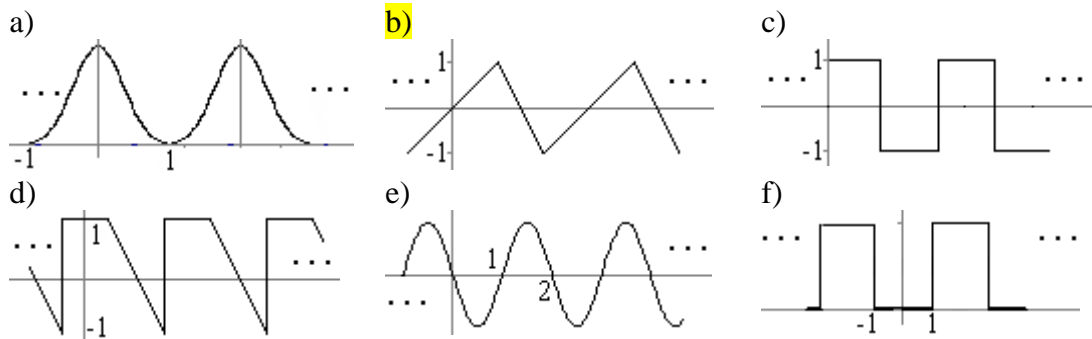

Solution

Uniform pdf means equal probability for all possibilities. That requires, for a periodic waveform to have only linear ramps, which is necessary but not sufficient condition. However, among the choices we have only one all-ramps waveform and it satisfies the conditions; b the triangle waveform.

2. What is the probability of $0 < X < 1$ when the pdf of X is given as below?

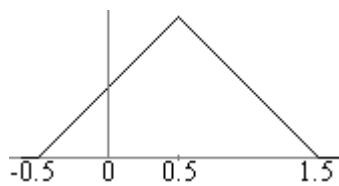

- a) 1.25 b) 0.33 c) 0.66
 d) 0.75 e) 0.25 f) 0.5

Solution

The value of the pdf at $x=0.5$ is 1 since the area underneath the curve must be equal to 1.0. Easiest way to find area underneath the curve within the asked range is to find the area that is outside the range and subtract it from 1. Since the slope of the line on the left is 1 it crosses the horizontal axis at 0.5. Therefore, the area between -0.5 and 0 is $0.5 \times 0.5 / 2$. Since we have a similar triangle between 1 and 1.5 total area outside the range becomes $0.5 \times 0.5 = 0.25$. Subtracting it from 1 we have $1 - 0.25 = 0.75$ and it is the answer d.

3. X is a random variable representing the values of the following periodic waveform ($T=3$) at any instant t . What is the expected value of the random variable X ?

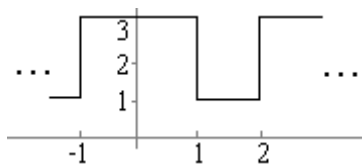

- a) 2.33 b) 1.33 c) 0
 d) 2.0 e) 1.0 f) 2.66

Solution

Average value must be between maximum (which is 3) and minimum (which is 1) and closer to 3 since the value of the waveform is 3 most of the time. So we have only one choice; 2.66. You can also do mathematics to find the same answer. The probability of having X at 3 is 2/3 and having it at 1 is 1/3. Therefore, the weighted average shall be

$$E(X) = \sum_{i=0}^1 p_i v_i = 3 \times \frac{2}{3} + 1 \times \frac{1}{3} = 2.66$$

4. Input to the given filter is white noise with $S(f) = 1$ and output noise power is 2 W. What is the noise-equivalent bandwidth of the filter?

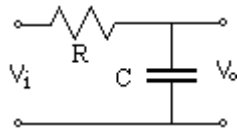

- a) RC b) 3.14 c) $1/\pi$
d) 0.5 e) 1.0 f) $2/\pi$

Solution

We know that $2B_{neq}H_{max} = P$. Our circuit is a low pass filter. At $f = 0$ (DC) our circuit is just a straight connector since capacitor has an impedance of infinity. Therefore, $H_{max} = 1$. Solving equation for B_{neq} we find that it is 1.0.

5. Output SNR of an amplifier is required to be 5 dB minimum. What is the maximum noise figure allowed when input has 10 dB SNR?
a) 2 dB b) 3.01 dB c) 5 dB d) -2 dB e) -3.1 dB f) 11.1 dB

Solution

Since $\left(\frac{S}{N}\right)_{o(dB)} = \left(\frac{S}{N}\right)_{i(dB)} - F_{(dB)}$, F must be 5 dB.

6. Two identical amplifiers with H_{max} of 3 are to be cascaded. Equivalent noise figure is found to be 5. What is the noise figure of a single stage?
a) 6.1 b) 5.44 c) 6.6 d) 4 e) 2.5 f) 4.6

Solution

$$F = F_1 + \frac{F_2 - 1}{H_{1max}^2} \Rightarrow 5 = F_1 + \frac{F_1 - 1}{3^2} \Rightarrow F_1 = 4.6$$

7. Average code length of the code {0, 10, 110, 111} is found to be exactly equal to the entropy of the source. What is the probability of the message with highest probability?
a) 0.5 b) 0.3333 c) 0.25 d) 0.4 e) 0.9 f) 0.04

Solution

Since the average code length is the best possible then the probabilities of symbols allow exact sub-division of the grouped symbols. From the codes we see that the Huffman three is nothing but

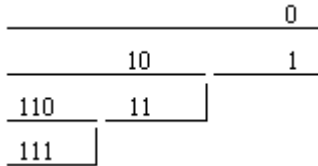

For the exact division, upper branch should have probability of 0.5 and corresponding lower branch would have probability of 0.5 too. Dividing other probabilities similarly we would have $v=\{0.5, 0.25, 0.125, 0.125\}$. We have already seen that the answer is 0.5.

8. Average code length of the code $\{1, 01, 001, 000\}$ is found to be exactly equal to the entropy of the source. What is the average information per source symbol (in bits)?
 a) 0.5 **b) 1.75** c) 1.25 d) 2.25 e) 2 f) 1.5

Solution

This is identical to previous question, but the codes are different which is ok. Calculating the entropy in bits on $v=\{0.5, 0.25, 0.125, 0.125\}$, we would find 1.75 which also is the average information per source symbol (the definition of entropy).

9. Entropy of a source with 4 symbols is maximum possible. What would be the average Huffman code length of this source?
 a) 1.5 b) 1.75 c) 1.25 d) 2.25 **e) 2.0** f) 0.5

Solution

Maximum entropy occurs when all symbols have equal probabilities. For a set with 4 symbols the maximum can only be 2. Average code length would be no different. One may calculate the entropy of the set $\{0.25, 0.25, 0.25, 0.25\}$ just to find the same number.

10. The following FSK signal has three distinct frequencies; f_c , $f_c - \varepsilon$ and $f_c + \varepsilon$. What would be the output of the FSK demodulator?

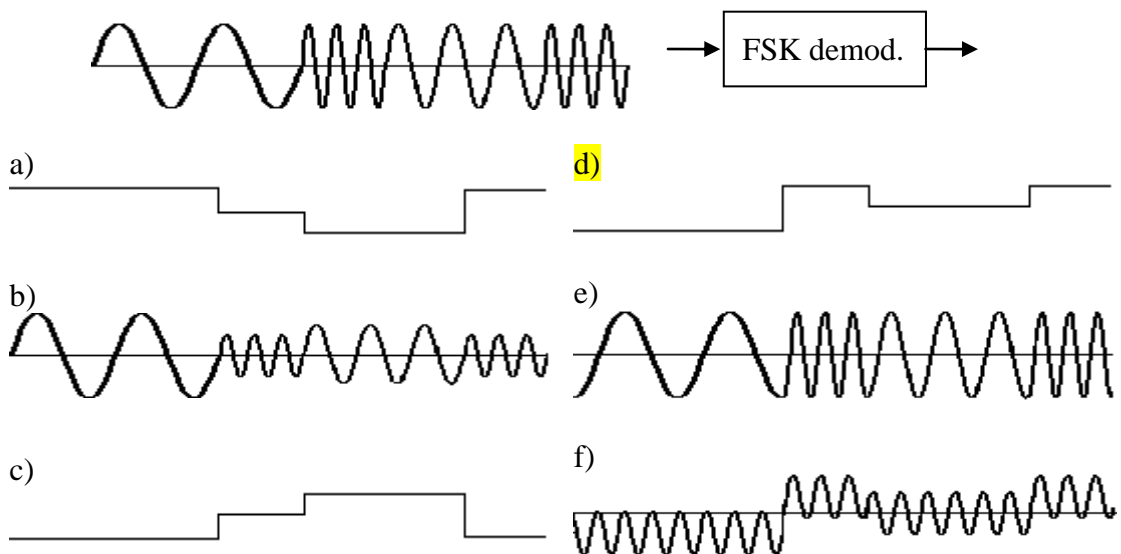

11. SNR of a telephone line is 40dB. What should the minimum bandwidth be in order to carry 256 kbps data?
 a) 9600 Hz b) 30 kHz c) 3000 Hz d) 3400 Hz e) 12512 Hz **f) 19266 Hz**

Solution

$$C = W \log(1 + SNR) \Rightarrow SNR_{dB} = 10 \log(SNR) \Rightarrow SNR = 10000$$

$$256k = W \log_2(10001) \Rightarrow W \cong 19266 \text{ Hz}$$

12. Power spectral density of a signal at the input of the following circuit is given as $S_i(\omega) = 4/(1 + \omega^2)$. What is the output power spectral density?

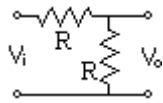

- a) $\frac{R^2}{2}$ b) $1 + \omega^2$ **c) $(1 + \omega^2)^{-1}$**
 d) 1.0 e) $(1 + \omega^2)^{-2}$ f) $\pi \omega^2 R$

Solution

The circuit given is just a voltage divider of $H=0.5$. Therefore,

$$S_o(\omega) = S_i(\omega) |H(\omega)|^2 \Rightarrow S_o(\omega) = \frac{4}{(1 + \omega^2)} |0.5|^2 = \frac{1}{(1 + \omega^2)}$$

Hence, the answer is c.

60. 09.06.2010 Final Exam (following 20 questions)

1. What is the response of the matched-filter when the input is a rectangular pulse as shown?

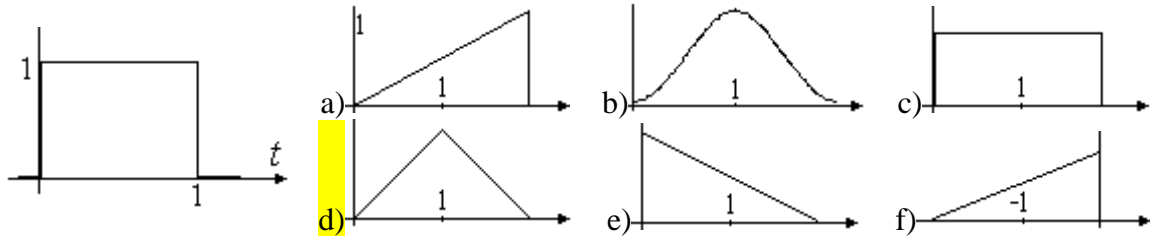

Solution

We obtain impulse response of a matched filter by flipping the signal in time and shifting it so that it is completely in positive side of the t axis (causal). Since our signal is rectangular shaped then the matched filter will look the same. The response of the filter to the input signal is the convolution of the input signal with the filter's impulse response. Convoluting a rectangular pulse with itself, we get a triangle like shown in answer d.

2. Input to the LTI system below is white Gaussian noise with mean $m=1$ and variance $\sigma = 1$. What is the mean value of the output signal?

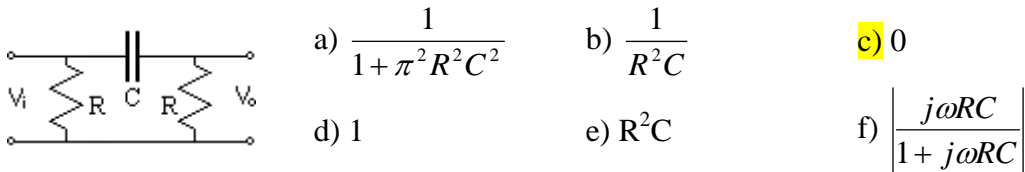

Solution

Because of the serial capacitor we would have no dc component at the output, that is zero mean. Output is also pulled to the ground by a resistor, having net effect of lower output voltage (without considering any possible load at the output).

3. $y(t) = \sin(t) + 2 \cos(2t)$ modulates a carrier with $f_c = 10$ using DSB-SC-AM. What is the magnitude spectrum of the modulated signal?

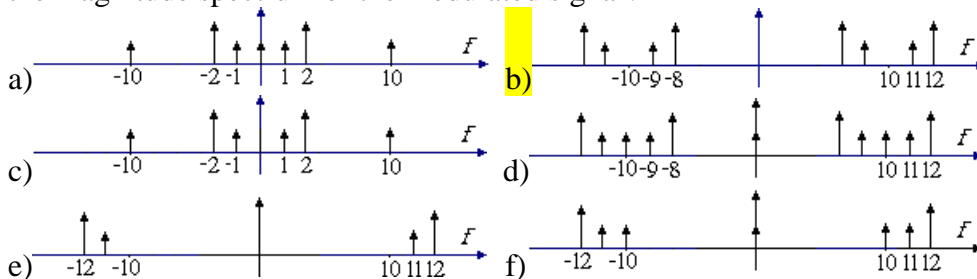

Solution

$$m(t) = y(t)c(t) = \cos(10t)(\sin(t) + 2 \cos(2t))$$

$$m(t) = 0.5 \sin(11t) + 0.5 \sin(9t) + \cos(12t) + \cos(8t)$$

So the answer is b.

4. Name the marked components of color video signal shown below.

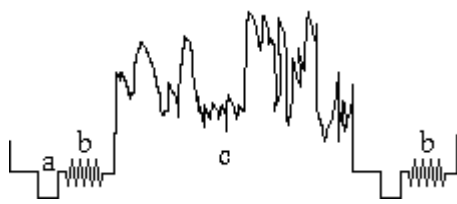

- | | | |
|---------------------------------|--|---|
| a) sound, color sync, vsb | b) vert. sync, backporch, video line | c) vert.sync, back porch, rgb |
| d) sync, line scan, audio | e) horiz. sync, color burst, line of video | f) color burst, chroma, luminance |

5. The pn code of 0000101011101100011111001101001 is used to spread the spectrum of a binary signal. How many times is the bandwidth expanded after spreading?
 a) 4 b) 16.2 c) 128 d) 2 e) 0.707 **f) 31**

Solution

Spreading ratio is directly proportional to the number of chips in the spreading sequence, so the answer is 31 as the spreading sequence has 31 chips.

6. X is a random variable representing the values of the following periodic waveform (T=4) at any instant t . What is the expected value of the random variable X?

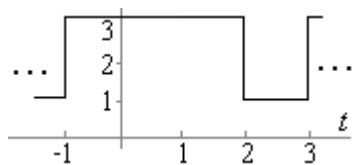

- | | | |
|---------------|--------|---------|
| a) 2.5 | b) 2.0 | c) 0 |
| d) 3.0 | e) 1.0 | f) 2.66 |

Solution

For a discrete values case $E = \sum_i^N p_i v_i$ where v_i s are the discrete values and p_i s are their probabilities. Therefore $E = 3 \times 3/4 + 1 \times 1/4 = 2.5$

7. What would be the probability density function of the following periodic waveform?

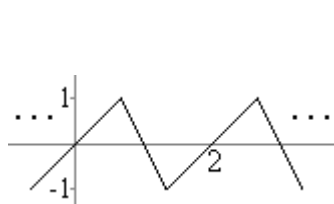

- | | | |
|----|------------|----|
| a) | b) | c) |
| d) | e) | f) |

Solution

Since the probability of having the signal value anywhere between -1 and 1 is same (uniform) we ought to choose an answer with uniform distribution. The only uniform distribution is in b and its range matches that of the signals.

8. Message signal $x(t)$ modulates a carrier with ASK and $y(t)$ is obtained. At the receiver a diode+RC envelope detector is used. What would be the output of the detector?

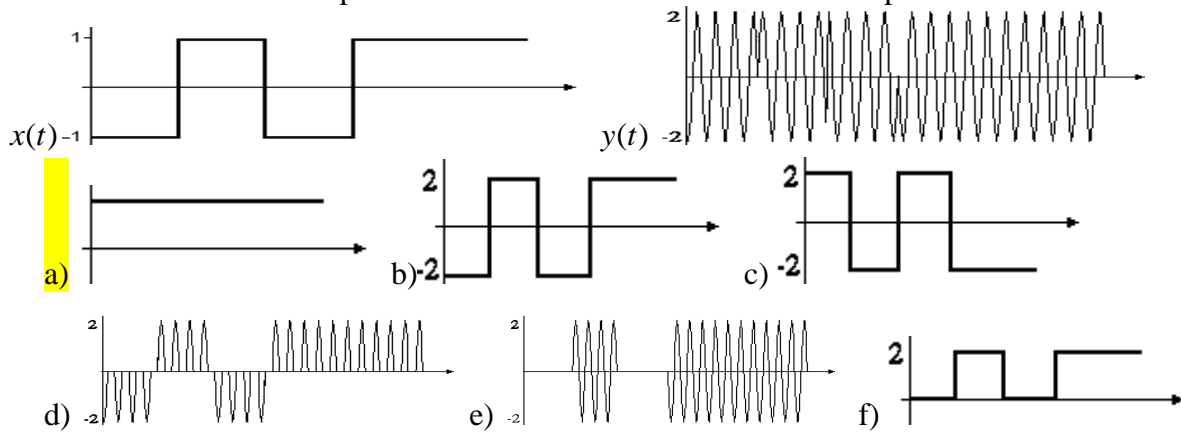

Solution

Independent of how the signal $y(t)$ is obtained, its demodulation(?) with an envelope detector gives out a constant value as the signal $y(t)$ has constant envelope. The only constant valued signal within answers is in a.

9. What is the entropy of the following periodic signal?

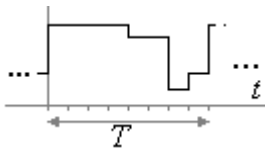

- a) 2.25 bits b) 1.5 bits c) 4.0 bits
 d) 2.0 bits e) 0.5 bits f) 3.75 bits

Solution

For a discrete valued periodic signal the entropy can be calculated using

$$H = -\sum_i^N p_i \log_2 p_i \text{ in bits. Only probabilities are used here, the actual values are not}$$

involved. The probabilities can be obtained by calculating the ratio of individual values to entire period. Using the slots marked on the signal graph for assistance,

$$p_1 = 0.5, p_2 = 0.25, p_3 = p_4 = 0.125$$

$$\text{Hence, } H = 0.5 \times \log_2 0.5 + 0.25 \times \log_2 0.25 + 0.125 \times \log_2 0.125 + 0.125 \times \log_2 0.125 = 1.75$$

Since no choice among answers is close to this number, this question will not be taken into account for grading.

10. What are the names of the operations performed before quantization at the transmitter end and after reception at the receiver end of voice lines in order to exploit the statistical characteristics of the voice signal?

- a) improve-protect b) amplify-attenuate c) emphasize-deemphasize
 d) equalize-de-equalize e) compression-expansion f) compounding-expression

11. Which of the following chip sequences can be an m-sequence in spectrum spreading?

- a) 111011001010000 b) 1010011101000001 c) 1010101111
 d) 1111000110100111 e) 10011100011110101 f) 01001110

Solution



m-sequence stands for maximal-length-sequence, meaning that, for a given number of D-type flip-flops, the maximum possible number of combinations and longest output sequence that can be obtained. This length is $2^N - 1$ for a given N flip-flops. Length can be 3, 7, 15, 31, 63 and so on. The only sequence that obeys this rule among choices is a. This sequence also satisfies other required properties (runs, balance, correlation).

- 12.** A stream consisting of symbols $A=\{00,01,10,11\}$ is coded with $B=\{1,01,001,000\}$ and 10010111010001 is obtained. What is the original binary stream?
 a) 0001101100011011 b) 101001000101001000 c) 0010101000001001101
 d) 00100100100111 **e)** 0010010000011100 f) 10010111010001

Solution

Separating the sequence into unique symbols
 1 001 01 1 1 01 000 1
 and finding the correspondence in set A for each symbol
 00 10 01 00 00 01 11 00
 we can see that this sequence is given in selection e.

- 13.** $x(t)$ is a periodical signal and has the following frequency spectrum. What is the period of $x(t)$?

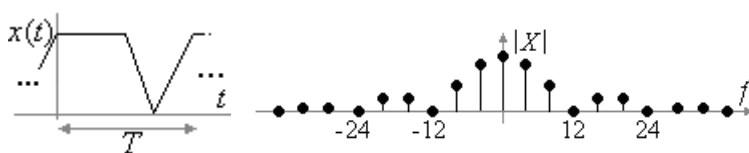

- a) 2 Hz b) 12 Hz **c)** 0.25
 d) 4 e) 12 f) 1 Hz

Solution

Period is the period of the fundamental frequency. f_0 is found to be 4 from the spectrum (frequency of the component closest to the zero other than zero). So the period is $1/4=0.25$.

- 14.** Name the modulation techniques used in analog TV signal to carry luminance, color and sound (in that order).
 a) FM, AM, PSK b) QPSK, FM, VSB c) FM, AM, PM
d) VSB, QAM, FM e) VSB, SSB, ASK f) AM, PM, FM

- 15.** What is the noise power at the output of an ideal band-pass filter with $|H(f)|=1$ between the cutoff frequencies of 1 Hz and 2 Hz, when input is white noise of $|X(f)|=4$?
 a) 2 b) 4π c) $16\pi^2$ d) 8π **e)** 8 f) 4

Solution

$Y(f) = X(f)|H(f)|^2$ where $Y(f)$ is the output power spectral density. The power is

$$P_Y = \int_{BW} 4x1df = 2 \int_1^2 4df = 8$$

16. How many bits are transmitted per phase shift in an M-ary PSK system?

- a) M b) 2^M **c) $\log_2 M$** d) 2 e) 8 f) M^2

17. Which modulation technique can the following waveform be an example of?

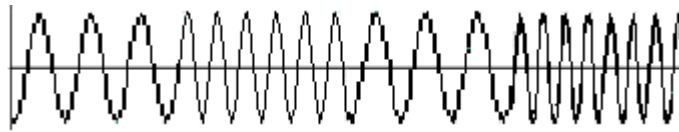

- a) ASK **b) FSK** c) PSK
d) AM e) QAM f) PWM

18. What is the modulation type of the output of the following system?

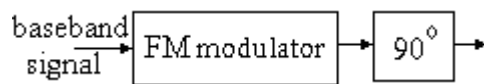

- a) PM b) VSB-AM c) DSB-AM
d) USB-AM **e) FM** f) QAM

Solution

Phase shifter at the end would not change magnitude and frequency properties of the signals, so it is still a FM-modulator.

19. A binary channel with symmetric error probability has probability of error $P_e=0.01$.

What is the probability of receiving zero (0) when probability of sending one (1) is 0.6?

- a) 0.598 b) 0.4 c) 0.396 d) 0.594 e) 0.406 **f) 0.403**

Solution

From total probability theorem, we can write

$$P(y=0) = P(x=0)P(y=0|x=0) + P(x=1)P(y=0|x=1) \text{ for BSC.}$$

In our case $P(y=0|x=1) = P_e = 0.01$, $P(y=0|x=0) = 1 - P_e = 0.99$, $P(x=0) = 0.4$ and $P(x=1) = 0.6$. Using these values, we find

$$P(y=0) = 0.4 \times 0.99 + 0.6 \times 0.01 = 0.402 \text{ as an answer.}$$

Closest choice to this answer is f.

20. Weak components of a signal with non-flat psd can be protected against channel noise and frequency dependent channel response by a pair of spectral operations. These components can be amplified before transmission and attenuated after reception leading to both flat end-to-end channel response and higher SNR. What are the names of these operations?

- a) protect-delete b) compression-expansion **c) emphasize-deemphasize**
d) channel equalization e) amplify-attenuate f) filter-spread

61. 25.03.2011 First Midterm Exam (following 12 questions)

1. Input to the filter described by the figure is $|X(f)| = 1$. What is the output power?

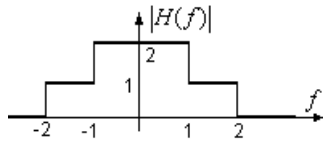

- a) 6 b) 5 c) 20π
d) 10 e) 3 f) 5π

2. Determine the power/energy of the single ramp given.

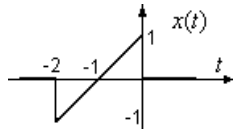

- a) 1 **b) 2/3** c) $4\pi/3$
 d) $4/9$ e) 4 f) 3

3. A 10Hz carrier is USB modulated with a tone signal and $A\sin(22\pi t + \theta)$ obtained (A and θ are arbitrary constants). What would be the modulated signal if DSB modulation were used instead?

- a) $B(\sin(21\pi t + \varphi) + \sin(19\pi t + \varphi))$ b) $\sin(22\pi t + \varphi) + 2\cos(18\pi t)$
c) $B(\sin(22\pi t + \varphi) + \sin(18\pi t + \varphi))$ d) $B\cos(22\pi t + \varphi)$
 e) $B(\sin(22\pi t + \varphi) + \cos(24\pi t + \varphi))$ f)
 $B(\sin(22\pi t + \varphi) + \sin(18\pi t + \varphi)) + A\cos(20\pi t + \theta)$

4. Following modulated signal is demodulated using an envelope detector. What would be the detector output?

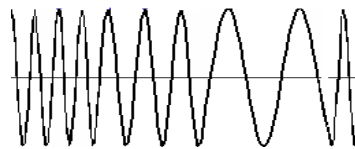

- a)** b) c)
 d) e) f)

5. What would loadless output power spectral density of the following LTI circuit be like when input is Gaussian white noise?

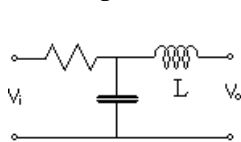

- a) b) c)
 d) **e)** f)

6. Name, in the order, components of composite video signal.

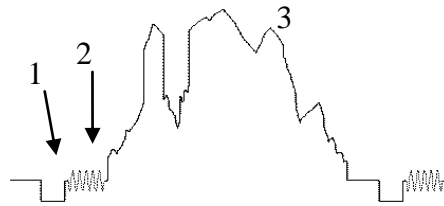

- a) horiz.sync., color burst, video line
- b) horiz.sync., front porch, vert. sync.
- c) vert.sync, blanking, color burst
- d) back porch, front porch, color
- e) chroma1, chroma2, luminance
- f) blanking, horiz.sync, video line

7. Name, in the order, color TV spectral components.

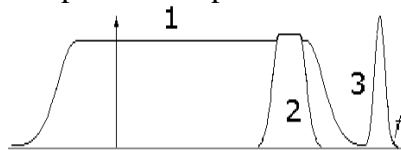

- a) color, intensity, carrier
- b) chrominance, luminance, color
- c) color burst, intensity, voice
- d) VSB-AM, QAM, FM
- e) chroma1, chroma2, luminance
- f) luminance, chrominance, sound

8. A square wave with period T is given. Find T that makes the power of the signal be A?

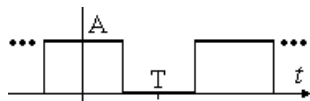

- a) 2A
- b) already is
- c) not possible
- d) $2/A^2$
- e) $A^2/2$
- f) A^2

9. The purpose of compression-expansion with A-law curves on voice lines is to

- a) reduce data to be transmitted
- b) obtain better time-frequency resolution
- c) sample high frequency components better
- d) perform smoother data-flow
- e) expand detailed voice components
- f) realize non-uniform quantization

10. What is the period of the signal whose magnitude spectrum is given?

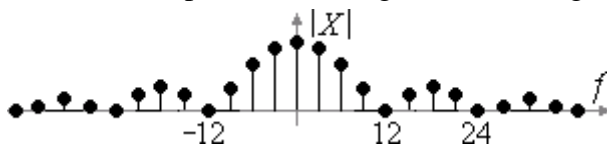

- a) 12
- b) $\pi/6$
- c) 1/6
- d) 1/12
- e) 1/3
- f) 3

11. Stereo FM uses the schema given below. What are the cutoff frequencies (in kHz) of ideal low-pass-filters (LPFs)?

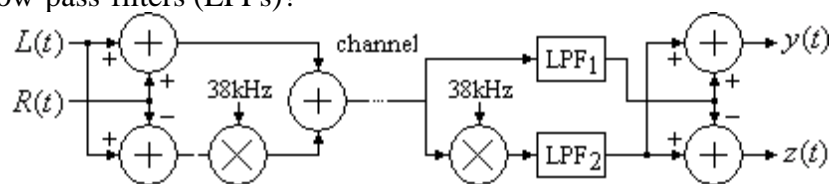

- a) 19, 38
- d) 38, 19

- b) 19, 19**
- e) 53, 53

- c) 53, 26
- f) 19, 53

12. An SSB modulator-channel-demodulator system is given. Assuming that LPF is sharp enough what would be $z(t)$ in order for the schema to be used for both USB and LSB?

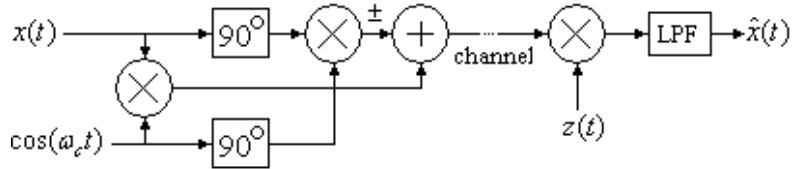

- a) $\sin(\omega_c t)$
- d) $\cos(\omega_c t)$**
- b) $-\sin(\omega_c t)$
- e) $-\cos(\omega_c t)$
- c) $\cos(\omega_c t + \pi/4)$
- f) $\cos(\omega_c t - \pi/4)$

62. 06.05.2011 Second Midterm Exam (following 12 questions)

1. Which of the following can be the probability distribution function of the random variable X representing the samples taken from the periodic signal given?

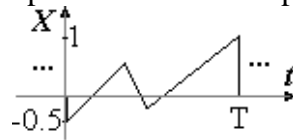

- a)
- b)
- c)**
- d)
- e)
- f)

2. A binary channel with signal values -1 and 1 is under additive noise with pdf given. Since transmission probability of 1 is three times higher than that of -1, what would be the channel output pdf? (this question removed from the exam)



- a)
- b)
- c)
- d)
- e)
- f)**

3. A Huffman code is generated for a set A of 9 symbols with probabilities v and it is found that $L_{avg} = H(v)$. What is the probability of a symbol that is represented by 2 bits?
 a) 0.75 b) 0.125 c) 0.5 **d) 0.25** e) 0.01 f) 0.135

4. Impulse response of a matched filter is given below. Which waveform is it optimized for?

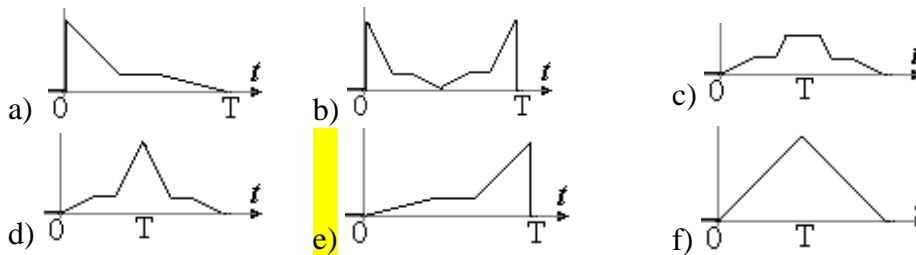
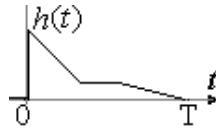

5. Symbols in the set {a, b, c, d} are ordered according to their probabilities from highest to lowest. What is the encoded binary stream for the symbol stream abacad?
 a) 100101010 **b) 01001100111** c) 00011010
 d) 11100110101 e) 0101011100 f) 01011110

6. Input to the filter $H(f) = \begin{cases} 1, & |f| < 2 \\ 0, & \text{otherwise} \end{cases}$ is white noise $\frac{N_0}{2}$. What is the noise-equivalent bandwidth of the filter?

- a) $0.25N_0^2$ b) $2N_0$ c) N_0 d) 3 e) 4 **f) 2**

7. Two identical amplifiers with available power gains of $H_{max}^2 = 10$ and noise figures of $F = 5$ are cascaded. What is the equivalent noise figure?

- a) 5.5 **b) 5.4** c) 10 d) 4 e) 50 f) 6.26

8. For symbols {00,01,10,11} in QPSK, I and Q values are given as $I=[1 \ 0 \ -1 \ 0]$ and $Q=[0 \ 1 \ 0 \ -1]$ respectively. What is the phase difference between the signals representing the symbols 01 and 10?

- a) 180 b) 45 **c) 90** d) 135 e) 0 f) 270

9. Bandwidth of a telephone line is 19266 Hz. What should be the SNR in order for this line to carry 256 kbps data?

- a) 50 dB b) 80 dB c) 30 dB d) 20 dB e) 10 dB **f) 40 dB**

10. The following FSK signal has three distinct frequencies; f_c , $f_c - \epsilon$ and $f_c + \epsilon$. What would be the output of the FSK demodulator?

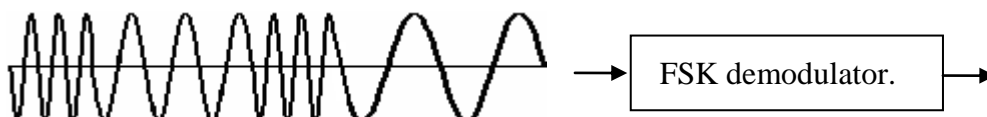

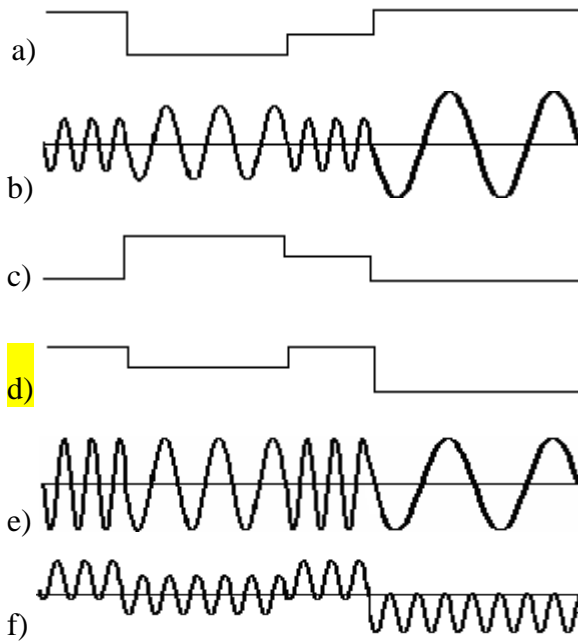

11. For a QPSK channel, probability of error is same for all transmitted symbols and is equal to 0.01. Symbol transmission probabilities are 0.1, 0.2, 0.3 and 0.4. What is the probability of erroneous reception?
 a) 0.01 b) 0.02 c) 0.025 d) 0.03 e) 0.04 f) 0.0125
12. For an asymmetric binary channel input probabilities are $P(0) = 0.4$ and $P(1) = 0.6$. Error probabilities are given as 0.01 when 1 is sent and 0.02 when 0 is sent. What is the probability of receiving 0?
 a) 0.502 b) 0.5 c) 0.4 d) 0.602 e) 0.398 f) 0.392

63. 08.06.2011 Final Exam (following 14 questions)

1. What is the minimum value of autocorrelation function for the PN sequence generator given with [3,1] and initialized with all 1. Assume binary values 0 and 1 are represented by -1 and 1 respectively?

- a) -1/3 b) 1/4 c) -1/4 d) 1/7 **e) -1/7**

2. What is the fundamental frequency of the following periodic waveform?

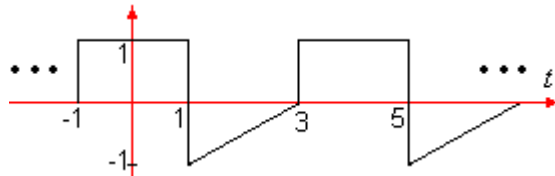

- a) 0.25 Hz** d) 0.5 Hz
b) 4 Hz e) 5 Hz
c) 0.333 Hz

Period of the signal is 4. So the fundamental frequency

3. What is the modulation type of the signal shown with an arrow in the frequency spectrum of the color TV signal?

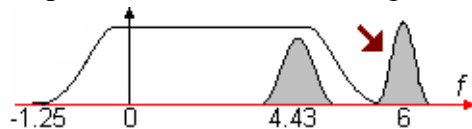

- a) VSB-AM d) QAM
b) FM e) AM
c) PM

4. When a SC-DSB-AM short-wave radio station broadcast a tone test signal a spectrum analyzer measured the following. Determine the frequency of the tone signal.

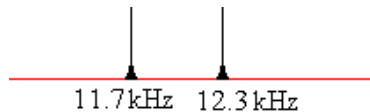

- a) 11.7 KHz **d) 300 Hz**
b) 12 kHz e) 600 Hz
c) 12.3 kHz

5. A FHSS communication system with 16 hopping channels and operating at 2.4 GHz ISM band uses 8-ary FSK. At each hop 3-bit symbols are transferred with 10 khops/sec hop rate. What is the bit rate?

- a) 48 kb/s b) 10 Mb/s **c) 30 kb/s** d) 24 kb/s e) 80 kb/s

6. Which of the following is not a multiple access method?

- a) Space Division Multiple Access **b) Phase Division Multiple Access**
c) Frequency Division Multiple Access d) Code Division Multiple Access
e) Polarization Division Multiple Access

7. What is the Signal to Noise Ratio at the filter output if the input is $x(t) = \sin(4\pi t) + n(t)$ where $n(t)$ is the noise whose power spectral density is constant $\Psi_n(f) = 0.125$?

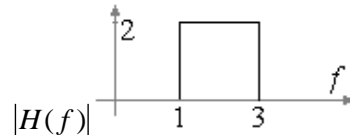

- a) 0.25 d) 4
b) 0.5 **e) 2**
c) $\pi/2$

8. What is the average information per source output for the source with symbol probabilities $[1/2 \ 1/4 \ 1/8 \ 1/8]$ T?

- a) 1.5 bits b) 2.0 bits **c) 1.75 bits** d) 2.25 bits e) 1.25 bits

9. A binary channel is under additive noise whose pdf is given below. Binary values 0 and 1 are represented by -0.8 V and 0.8 V and their probabilities are 0.4 and 0.6 respectively. Decision threshold is selected to be 0 V at the receiver. What is the probability of error?

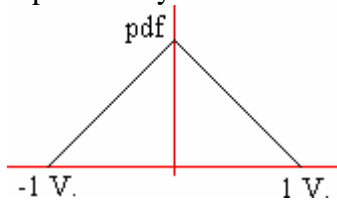

- a) 0.04 **d) 0.02**
 b) 0.01 e) 0.0281
 c) 0.048

10. A binary channel with signal values -0.7 and 0.7 is under additive noise with pdf given. Since transmission probability of 0.7 is three times higher than that of -0.7, what would be the channel output pdf?

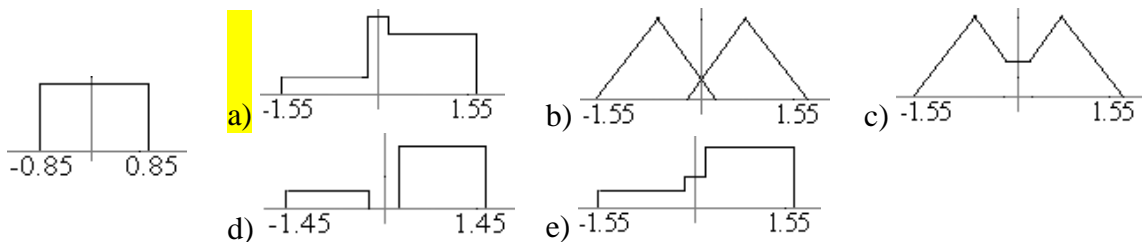

11. Huffman code for the symbol set {a, b, c, d} is given as {1,01,001,000}. What is the decoded stream for the binary stream 01100110001?

- a) abcada b) acabad c) baabaa **d) bacada** e) dacaba

12. Impulse response of a matched filter is given. What is the filter response for the matched signal?

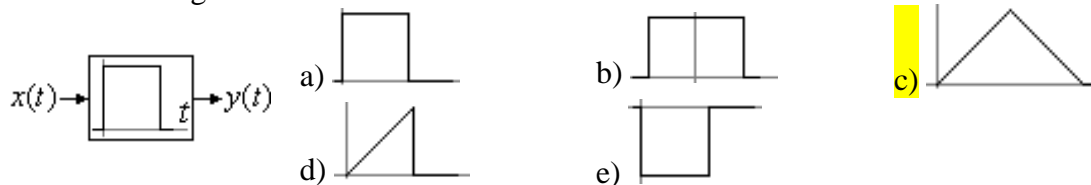

13. Which one of the following can be the constellation diagram of DBPSK?

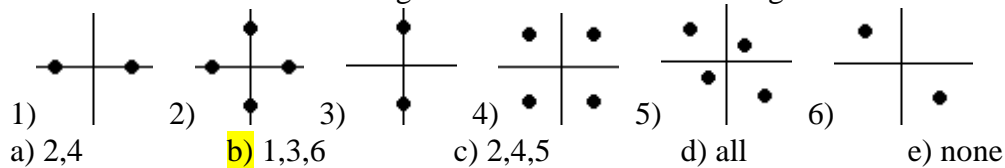

14. In some voice communication systems, weak components of the signal that are vulnerable to channel noise are amplified at the transmitter and attenuated at the receiver so that SNR is improved. What are these operations are called?

- a) Amplification-Attenuation b) Compression-Expansion
 c) Spreading-Despreading d) Comanding-Expanding
e) Preemphasis-Deemphasis

64. 23.03.2012 First Midterm (following 12 questions)

1. A linear filter and input signal frequency characteristics are given. What is the output signal power?

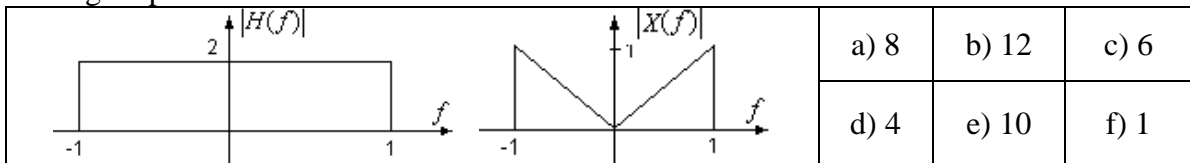

This question is removed from the exam since the frequency characteristics of the signal should have been given for $|X(f)|^2$ instead of $|X(f)|$.

2. A periodic signal is given. What is the lowest frequency in it?

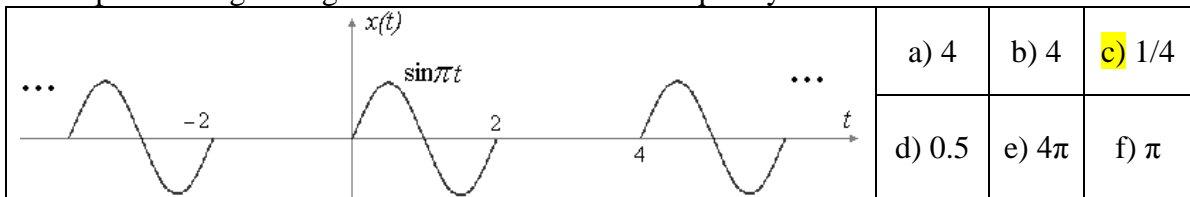

How come?: The period of the given signal is 4. Since the fundamental frequency is the lowest frequency in the periodic signal (other than DC) and it is $1/T$, the lowest frequency is $1/4$.

3. A periodic signal is given. What is the average value of it?

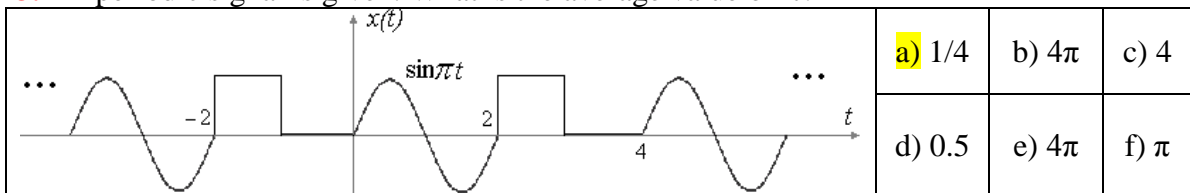

No need to calculate : Since the average of the sections excluding $t=(2,3)$ is zero the value within $t=(2,3)$ determines the average. The value is 1 (same as the highest value of $\sin(\pi t)$). The average is therefore $1/T$ which evaluates to $1/4$.

4. What would be the output power spectral density of the following LTI circuit like when input is AWG noise?

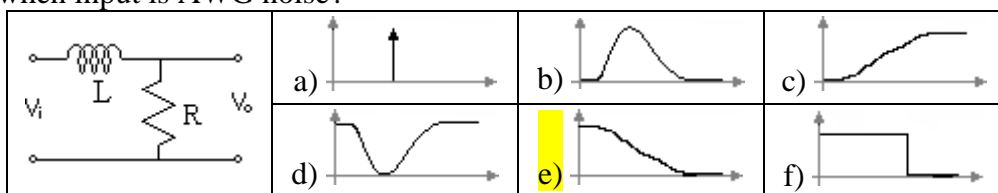

It is a low-pass filter, but not an ideal filter like the one in f.

5. A 12Hz carrier is LSB modulated with a tone signal and $A\sin(22\pi t + \theta)$ obtained (A, B, θ and φ are arbitrary constants). What would be the modulated signal if conventional AM modulation were used instead?

- a) $\sin(22\pi t + \varphi) + 2\cos(26\pi t)$ b) $B(\sin(11\pi t + \varphi) + \sin(13\pi t + \varphi)) + \cos(12\pi t + \varphi)$
 c) $B(\sin(22\pi t + \theta) + \sin(24\pi t + \theta))$ d) $B\cos(22\pi t + \varphi) + A$
 e) $A(\sin(22\pi t + \varphi) + \sin(26\pi t + \varphi))$ **f) $B(\sin(22\pi t + \varphi) + \sin(26\pi t + \varphi)) + A\cos(24\pi t)$**

Conventional AM includes some carrier along with the upper and lower sidebands. Since the frequency of the given signal is 11Hz, the upper side band correspondent must be at

13Hz. Therefore, we should have a combination of sinusoids at 11, 12 and 13 Hz. This signal is in the choice f.

6. What should be the value of C in the given circuit for the value of output power spectral density function to be half of the input psd value at $\omega_c = 1$ when the input is white noise?

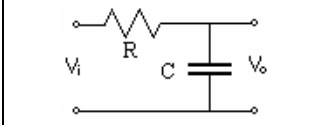
| | | | |
|---|------------|------------------------------|------------------------------|
|  | a) $C=R$ | b) $C=1/R$ | c) $C=1/R$ |
| | d) $C=1-R$ | e) $C = \omega_c R^2$ | f) $C=1$ |

How? : For a solution see the exam dated 24.03.2007.

7. A baseband signal whose spectrum is given is sampled but later seen that upper 4 kHz is aliased because of lower sampling rate than necessary. What would be the optimal cutoff frequency for an ideal antialiasing filter?

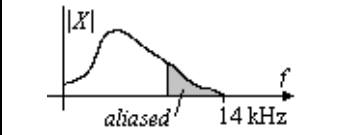
| | | | |
|---|-----------------|----------|----------|
|  | a) 12kHz | b) 10kHz | c) 14kHz |
| | d) 28kHz | e) 20kHz | f) 24kHz |

The situation is illustrated in the figure below.

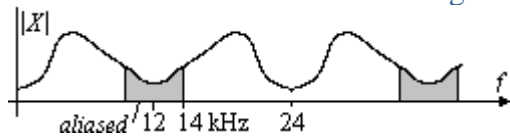

Removing components with frequencies higher than 12kHz would eliminate aliasing

8. Following modulated signal is demodulated using an envelope detector. What would be the detector output?

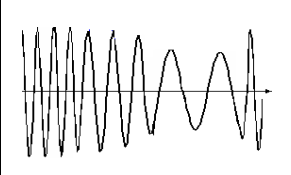
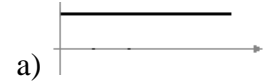
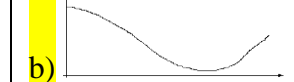
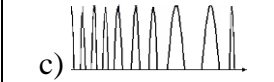
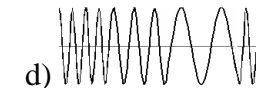
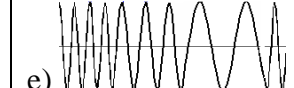
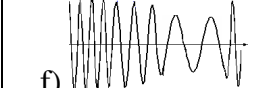
| | | | |
|---|--|--|--|
|  | a)  | b)  | c)  |
| | d)  | e)  | f)  |

9. An illustration of a single scan line signal of color TV is given. What is the modulation types used in the part pointed at by an arrow?

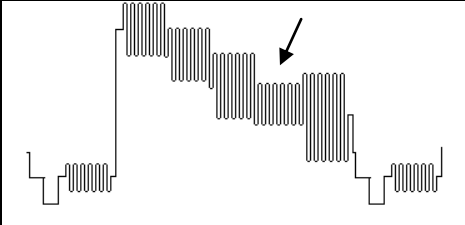
| | | | |
|---|--------------------|-------------|------------|
|  | a) VSB, AM | b) VSB, PM. | c) QAM, PM |
| | d) VSB, QAM | e) AM, FM | f) VSB, FM |

10. What is the main reason that nonuniform quantization levels are preferred over equally distanced levels on phone lines?

- a) Nonuniform quantization levels are cheaper to obtain and easier to maintain.
- b) They represent the freedom to choose from many
- c) Minimize average quantization error statistically**

- d) It is easier to manufacture ADCs with nonuniform quantization levels.
- e) English language has more consonants than vowels.
- f) Optimize energy necessary for analog to digital conversion.

11. What is the main advantage of FM over AM?

- a) FM delivers more power per unit time than AM.
- b) It is more efficient to carry video over FM than any other method.
- c) Unlike AM, FM has no patent issues.
- d) Electronics for generating and detecting FM signals are simpler and cheaper.
- e) FM is more robust against noise.**
- f) FM has lower bandwidth than AM.

12. One of the problems that PAL tries to solve in NTSC is

- a) incorrect color representation because of the use of YUV color space.
- b) incorrect horizontal synchronization due to the length of blanking period.
- c) low signal to noise ratio in high frequency channels.
- d) low refresh rate.
- e) low operating frequency of color burst in back porch.
- f) color distortion caused by phase shifts due to multipath effects.**

65. 11.05.2012 Second Midterm (following 13 questions)

1. Which of the following can be the probability distribution function of the random variable X representing the samples taken from the periodic signal with period T given below?

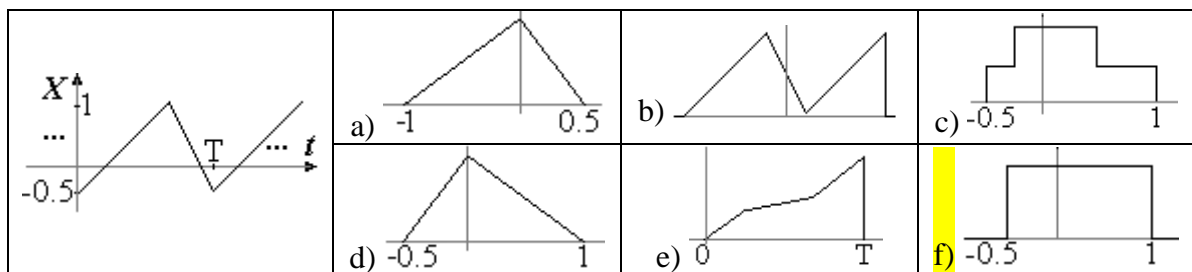

Within the period T the function has two sections; linearly increasing part from -0.5 to 1 and linearly decreasing part from 1 down to -0.5 . In each section, the probability of function to assume a certain value is same with any other value, so the pdf is flat. Combining two flat pdfs with the same range gives a flat pdf again. Therefore the answer is **f**.

2. A binary channel with signal values -0.45 and 0.45 is under additive noise with pdf given. Transmission probability of 0.45 is three times higher than that of -0.45 , what would be the probability of error when 0.0 is selected to be the decision boundary?

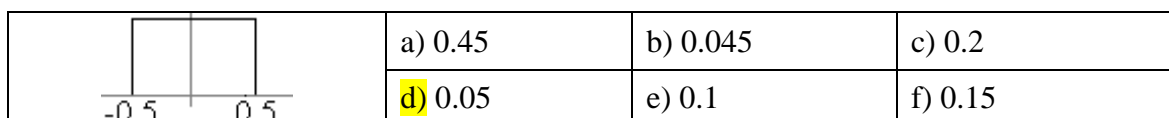

The probability of error when 0.45 is transmitted is the area given in the figure below

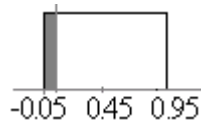

Since the height of the marked area is 1 the area is 0.05. The error is the same when -0.45 is sent. Using the total probability theorem $0.75 \times 0.05 + 0.25 \times 0.05$ we get $P_e = 0.05$.

3. What would be the impulse response of a matched filter for the waveform given?

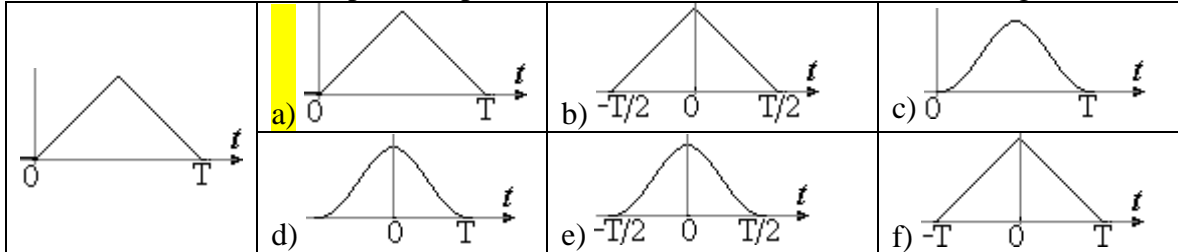

Impulse response of a matched filter is the one of the infinite number of causal versions signal to be matched flipped along the time axis.

4. What is the minimum numbers of bits that should be assigned for a symbol with probability of occurrence of 0.22 in a 11 symbol alphabet (in Huffman code)?

- a) 1 **b) 2** **c) 3** d) 4 e) 2.2 f) 2.18

The number of bits assigned to a symbol in a Huffman code can be at most 1 bit away from its information value $I_E = -\log(P_E) = -\log_2(0.22) = 2.18$. Therefore the number of bits that is assigned to the symbol can be 2 or 3.

5. Huffman code for the symbol set $v = \{a, b, c, d\}$ has the average code length L_{avg} identical to source entropy $H(z)$. What is the self-information of the symbol with the lowest probability?

- a) 1.5 b) 4 c) 2.5 **d) 3** e) 2 f) 1

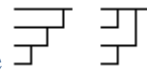

Possible Huffman trees for a 4 symbol alphabet are . We should only consider the first one since the second one requires that all probabilities are the same. In that case, symbol with the lowest probability is assigned 3 bits (Follow Huffman tree).

6. Input to the filter $H(f) = \begin{cases} 1 - |f|, & |f| < 1 \\ 0, & \text{otherwise} \end{cases}$ is white noise $\frac{N_0}{2}$. What is the noise-

equivalent bandwidth of the filter?

- a) N_0^2 b) $2N_0$ c) 2 d) 1 **e) 1/3** f) 0.5

7. What would be the logical choice of order for a cascaded amplifiers with noise figures of $F_1 = 5$, $F_2 = 2$, $F_3 = 1$ and available power gains of $H_{max}^2 = 10$ (all same)?

- a) 3,2,1** b) 1,2,3 c) 1,3,2 d) 3,1,2 e) 2,1,3 f) 2,3,1

It is logical to have a first stage amplifier with the lowest F value when all other conditions are the same. Amp with the lowest F value is the 3rd one. The one with the second lowest F should be the next stage. Therefore the order should be 3,2,1.

8. What is the phase difference between signals representing 011 and 001 for Gray-coded constellation placement of symbols {111,110,010,011,001,000,100,101} in 8-ary PSK?

- a) 30 **b) 45** c) 90 d) 180 e) 0 f) 135

The constellation points for 011 and 001 are neighbors. Since we have 8 points in the constellation diagram the neighboring points have 45 degrees phase difference between them.

9. Which of the following is not a reason to use spectrum spreading?

- a) Perform multiple access in a shared media b) Make the signal harder to detect
 c) Make signal robust against jamming d) Obtain better time-resolution
 e) Jam hostile transmitters' signals **f) Reduce transmission power**





10. What is the purpose of preemphasis-deemphasis process?

- a) Filter out high frequency noise components when low frequency components are weak.
 b) Improve transmission power performance and efficiency.
c) Make signal more robust against channel noise where signal or channel is non-flat.
 d) Perform better performance against quantization noise when levels are nonuniform.
 e) Do problem-free multiple access on wideband digital channels.
 f) Emphasizing the signal improve the quality of the reception.

11. Which of the following is really a property of PN-sequences?

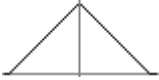
- a) The number of zeros is even
 b) The length of sequence is an odd integer
 c) The autocorrelation is 2 at maximum.
 d) Half the runs are two chips long
e) Number of zeros and ones differ by at most one.
 f) Generator of the sequence has odd number of taps.

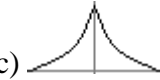
12. Frequency characteristic of a linear time invariant filter is given. The input to the filter is additive white Gaussian noise with $\sigma = 1$ and $m = 0$. What would be the pdf of the output like?

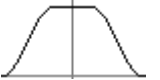
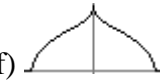
| | | | |
|--|--|--|--|
| $H(f) = \begin{cases} 1 - f , & f < 1 \\ 0, & \text{otherwise} \end{cases}$ | a)  | b)  | c)  |
| | d)  | e)  | f)  |

When input pdf of a linear system is Gaussian, the output pdf is Gaussian too. σ and/or m may be different though.

13. Which one of the following can be the constellation diagram of DBPSK?

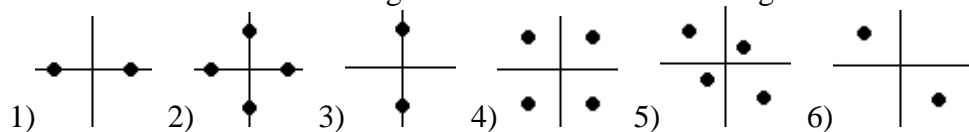

- a) 1,3,6** b) 2,4 c) 2,4,5 d) 1,3 e) 1 f) 2

66. 06.06.2012 Final Exam (following 13 questions)

1. Why is asynchronous serial communication preferred over synchronous serial communication?
 - a) Parallel communication is much faster than serial communication
 - b) Synchronous communication is difficult to maintain
 - c) Synchronization between transmitter and receiver is difficult
 - d) Clocking is expensive
 - e) Signal and clock arrival times might be different.**
 - f) Clock signal has high frequency and is distorted by the cable.

2. What is the fundamental frequency of the following periodic waveform?

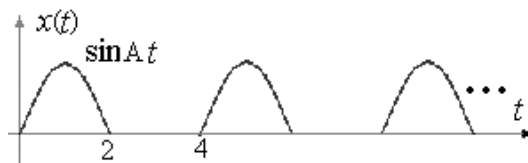

- a) 0.25
- b) $A/2\pi$
- c) 2
- d) A
- e) 0.5
- f) 0.5A

The period of the signal is seen to be 4. $f_i = 1/T = 0.25$.

3. Which of the following is not a method for multiple access to a shared media?
 - a) Space Division Multiple Access
 - b) **Phase Division Multiple Access**
 - c) Frequency Division Multiple Access
 - d) Code Division Multiple Access
 - e) Polarization Division Multiple Access
 - f) Time Division Multiple Access
4. A binary channel is under additive noise whose pdf is given below. Binary values are represented by -0.7 V and 0.7 V and their probabilities are 0.3 and 0.7 respectively. What is the probability of error when decision threshold is 0 V at the receiver?

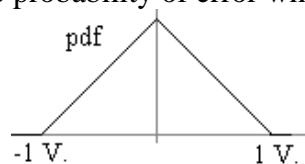

- a) 0.09
- b) 0.07
- c) 0.049
- d) 0.045**
- e) 0.03
- f) 0.042

When 0.7 V is transmitted the probability of incorrect decision is shown as the gray area in the figure



Similar error area would be seen when a -0.7 V is assumed to be transmitted. Calculating the area shown yields $P_e=0.045$.

5. Huffman code for the symbol set {00, 01, 10, 11} is given as {0, 10, 110, 111}. What is the decoded stream for the Huffman coded stream 1001100010111?
 - a) 1101000111
 - b) 1001100010111
 - c) 0100100000111**
 - d) 000110110001
 - e) 0101000111
 - f) 010010011100

Starting from the leftmost bit of 1001100010111, variable length codewords are found from the Huffman code and the decoded stream is constructed from corresponding fixed length codes.

6. 4.43 MHz is the frequency of an oscillator in color TV receivers. This oscillator must be phase locked with the burst signal transmitted in every line. What is this signal used for?

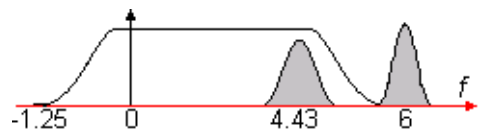

- a) This is the line synchronization signal
- b) Phase difference between this and video signal determines color.**
- c) This signal determines the end of the frame.
- d) Indicates that the TV is receiving the signal.
- e) End of HS is marked with this signal
- f) Determines the brightness

7. How many bits are transmitted per phase shift in 8-ary PSK?

- a) 1
- b) 2
- c) 3**
- d) 4
- e) 1.5
- f) 3.5

8. When a DSB-SC-AM short-wave radio station broadcasts a tone test signal a spectrum analyzer displays the following. Determine the frequency of the carrier.

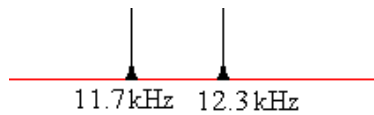

- a) 11.7 KHz
- b) 0.3 kHz
- c) 12.3 kHz
- d) 300 Hz
- e) 11.7 kHz
- f) 12 kHz**

The possible carrier, when not suppressed, would have been in the middle of two bars at frequencies 11.7 and 12.3 kHz, and this would be 12 kHz.

9. Which of the following is most-likely a FSK signal?

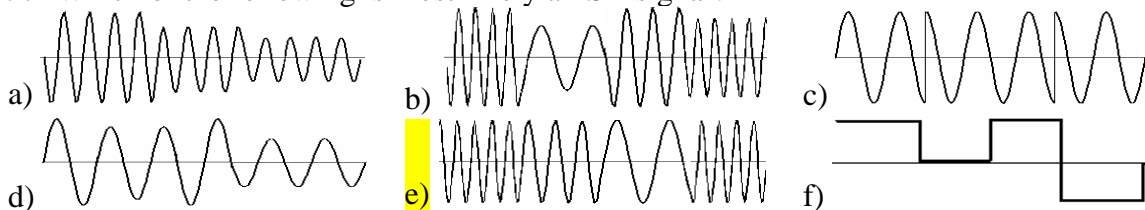

FSK is a modulation type that the frequency of the carrier is shifted between finite number of values and it is expected to have no amplitude changes. This is satisfied with the e. answer

10. What is the response of the matched filter to the matched input signal given?

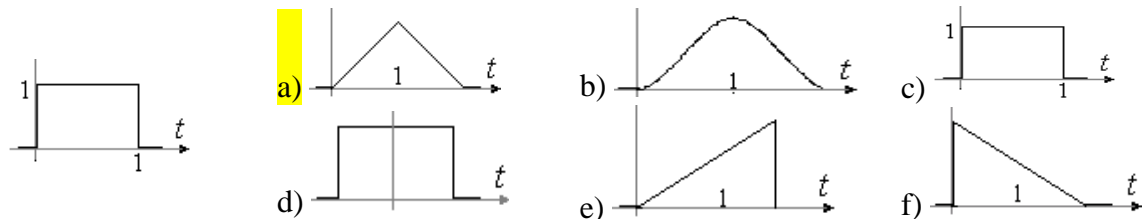

Convolution of two identical rectangular pulse is a triangle waveform.

11. What is the period T for the signal power to be 27 for the following periodic signal?

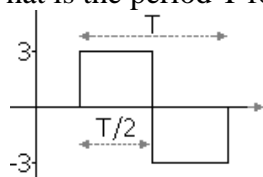

- a) 9
- b) $\sqrt{3\pi}$
- c) 3
- d) 2
- e) 3π
- f) not possible**

It is not possible to change the power of a periodic signal by changing its period. The power of the given signal is $P_x = \frac{1}{T} \int_{\alpha}^{\alpha+T_1} |x(t)|^2 dt = \frac{1}{T} \int_{\alpha}^{\alpha+T_1} |3|^2 dt + \frac{1}{T} \int_{\alpha+T_1}^{\alpha+T_2} |-3|^2 dt = 27$ and is independent from the period T.

12. What would be the spectrum of the modulated signal if SSB-SC-AM modulation is performed with the following message and carrier signals?

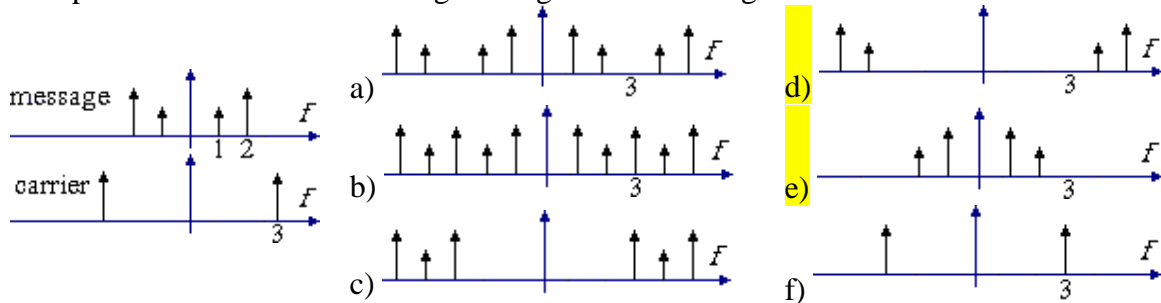

Both USB and LSB answers are correct.

13. What is the average information per source output for the source with symbol probabilities $P(a)=1/2, P(b)=1/4, P(c)=1/8, P(d)=1/8$?

- a) 1.5 bits b) 2.0 bits **c) 1.75 bits** d) 2.25 bits e) 1.25 bits

$$H = -\sum_{i=1}^4 P_i \log_2 P_i = 1.75$$

67. 22.03.2013 1st Midterm (following 12 questions)

1. Which one of the following can be the constellation diagram of QPSK?

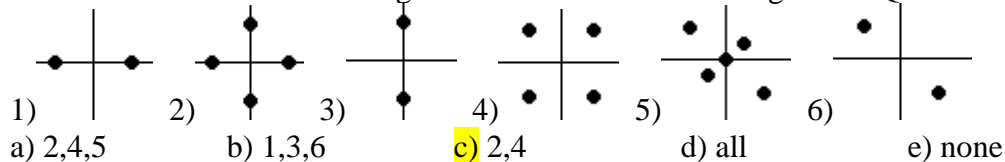

2. Message signal $x(t)$ modulates a carrier with ASK and $y(t)$ is obtained. At the receiver a synchronous demodulator is used. What would be the output of the detector?

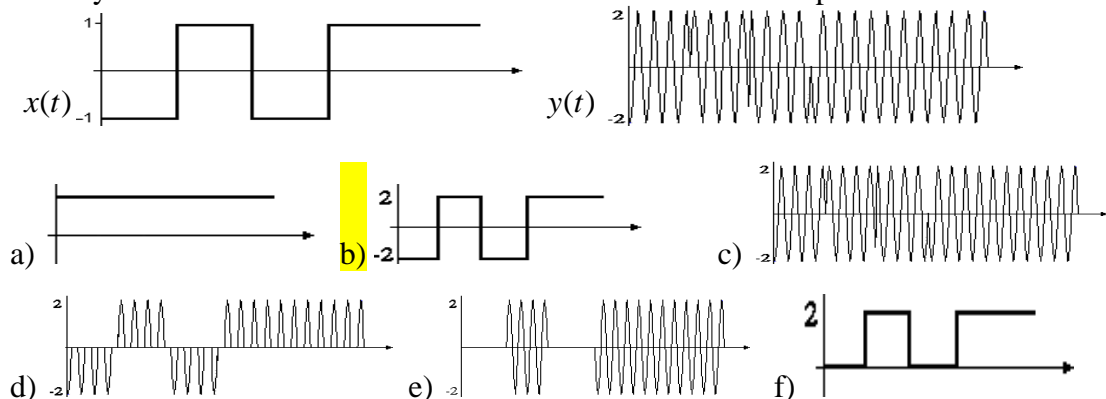

Synchronous demodulator consists of a mixer that multiplies the incoming signal with the in-sync carrier followed by a low-pass filter. It theoretically recovers the original baseband signal back. Therefore the answer is b.

3. What is the period of the signal whose magnitude spectrum is given?

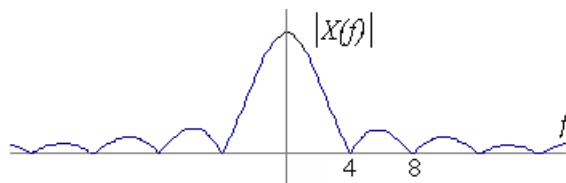

- a) 1/4 b) 1/8 **c) aperiodic**
d) 4 e) 8 f) 1

For the periodic signals the spectrum would have a fundamental frequency component and its harmonics. Between them there would not be any component. Since the spectrum shape given is continuous, it is not periodic.

4. A periodic waveform with period T is given. What is the frequency of the second harmonic?

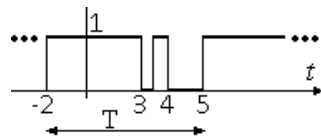

- a) 2/7** b) 5 c) 3/14
d) 1/5 e) 3/10 f) 2/5

The fundamental frequency is $1/T=1/7$. The second harmonic is $2f_0=2/7$.

5. A sinusoidal carrier is DSB-SC-AM modulated with a tone signal and $B(\sin(88\pi t + \varphi) + \sin(96\pi t + \varphi))$. What is the frequency of the tone signal?
a) 46 Hz b) 8 Hz c) 48 Hz
d) 88 Hz e) 4 Hz f) 44 Hz

The answer should have been 2 Hz, but since this answer is not in the choices this question is removed from the exam.

6. What would be the output power when the filter and input signal power spectral densities are given as shown?

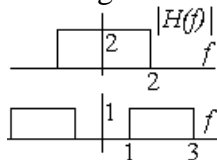

- a) 1 b) 4 c) 2
d) 8 e) 6 f) 12

$$P_o = \int_{-\infty}^{\infty} X(f) |H(f)|^2 df = 2 \int_1^3 1 \cdot 2^2 df = 8.$$

7. Name, in the order, components of composite video signal.

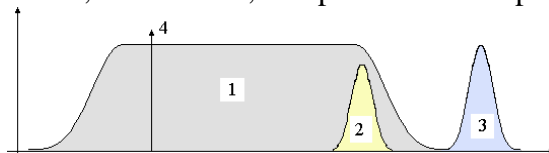

- a) VSB, QAM, FM, AM b) pic. carrier, audio, video, color burst
c) audio, video, color, pic. carrier **d) luminance, chrominance, audio, pic. carrier**
e) intensity, audio, color, color burst f) picture, hor. sync, audio, ver. sync

8. A DSB-SC-AM system and its spectrum are given. What is the filter cut-off frequency?

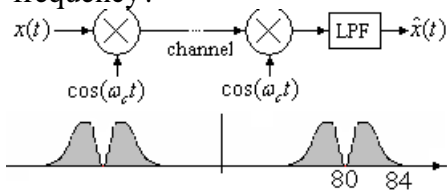

- a) 4
b) 80
c) 84
d) 82
e) 8
f) 41

Filter cutoff frequency is the baseband bandwidth. The mixer output have the message signals centered at 0 and 160Hz, so the filter is needed. One may think that he/she can opt to have a cutoff frequency between 4 and 156Hz, but spectrum is not guaranteed to not have any signal in this range since channel may introduce noise and spurious components that should be filtered out.

9. What is the name of the portion of the composite video signal pointed at with the arrow?

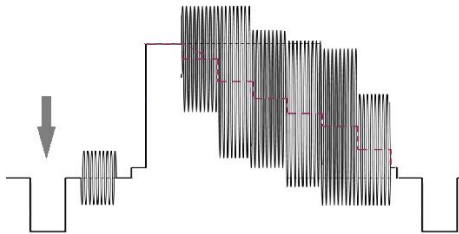

- a) color burst
b) front porch
c) luminance
d) vertical synch
e) chroma signal
f) horizontal synch.

10. What is the type of modulation this waveform exemplifies?

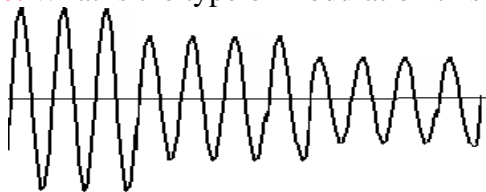

- a) PSK
b) ASK
c) FSK
d) QPSK
e) PM
f) FM

Only the amplitude of the sinusoidal changes and it assumes discrete values.

11. What is the modulation when both amplitude and phase assume finite number of values as shown?

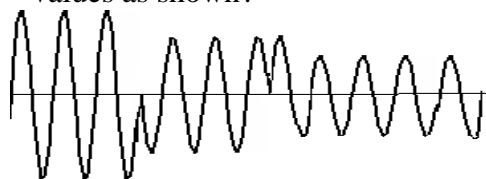

- a) PSK
b) ASK
c) APM
d) QAM
e) QPSK
f) QPM

The phase and amplitude of the sinusoidal assumes discrete values. This is called QAM. Actually, the term QAM is also used for the continuous value changes in both amplitude and phase, that is, it does not have to have finite number of values of amplitude and phase. But the term is the same in the case of finite number of values too.

12. What would the output power spectral density of the following LTI circuit be like when input is white Gaussian noise?

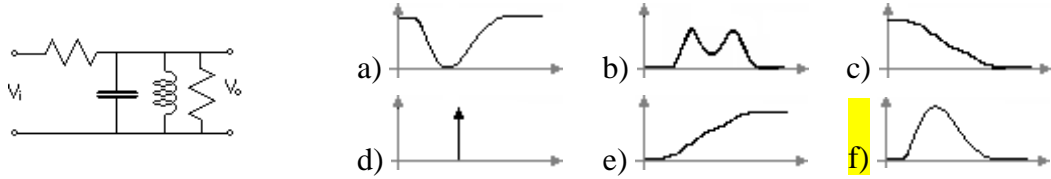

68. 10.05.2013 2nd Midterm (following 13 questions)

1. Which of the following can be the probability distribution function of the random variable X representing the samples taken from the periodic signal given?

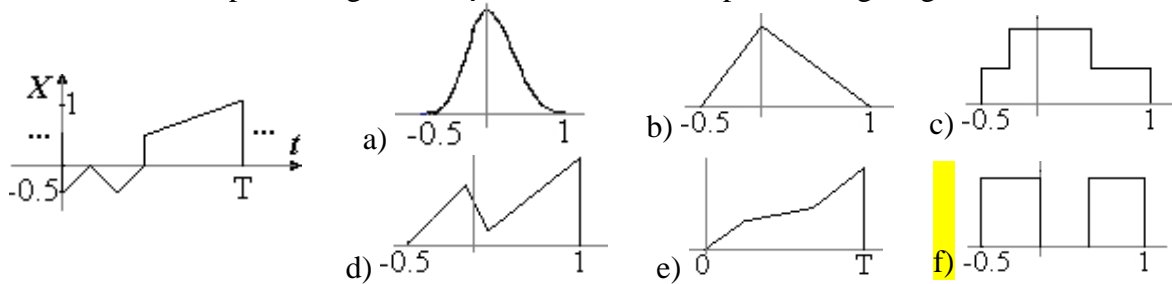

2. A binary channel with signal values -1 and 1 is under additive noise with pdf given. Since transmission probability of 1 is three times higher than that of -1, what would be the channel output pdf?

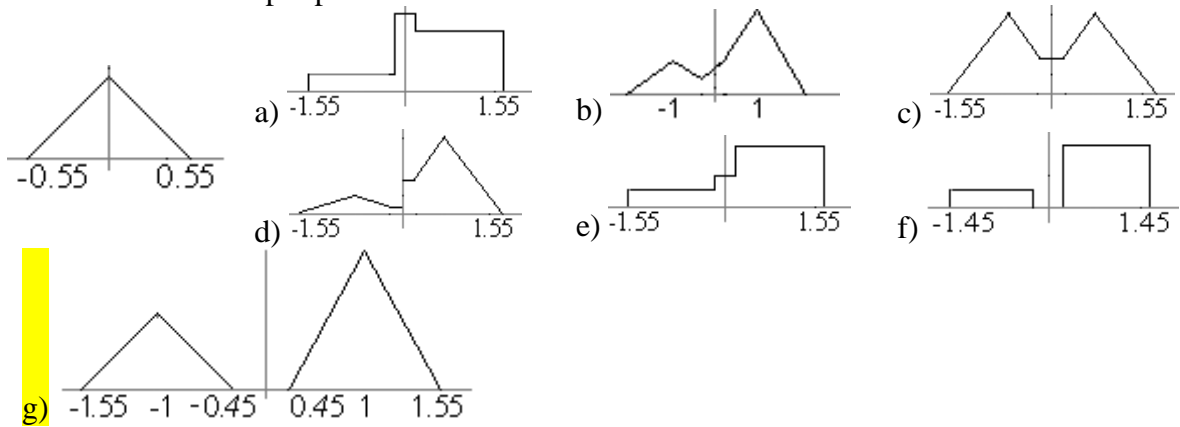

3. An information source generates four symbols with probabilities [0.5, 0.25, 0.125, 0.125]. What is the average information per source symbol?

- a) 1.75 b) 0.125 c) 0.5 d) 0.25 e) 2.0 f) 1.135

4. What is the matched filter response for the waveform given?

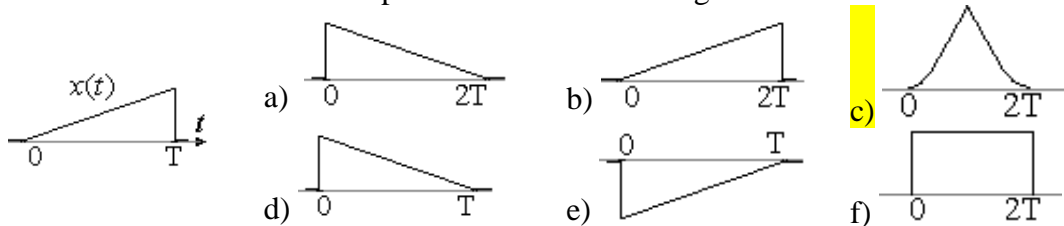

Matched filter response is for a given waveform is basically the autocorrelation function of the waveform provided that the filter is causal.

5. Symbols in the set {a, b, c, d} are assigned the codes {111, 10, 0, 110}. What is the decoded stream for the coded stream 0101110111110 ?
 a) dabaca b) abcd c) cdbbdb d) bbadac **e) cbacad** f) bacada

6. Input to the filter $H(f) = \begin{cases} 1, & |f| < 2 \\ 0, & \text{otherwise} \end{cases}$ is white noise with spectral density $\frac{N_0}{2}$.

What is the output power?

- a) 4 b) N_0 c) 3 **d) $2N_0$** e) $0.25N_0^2$ f) 2

$$P_0 = \int_{-\infty}^{\infty} S_o(f) df = \int_{-\infty}^{\infty} S_i(f) |H(f)|^2 df = 2 \int_0^2 \frac{N_0}{2} \times 1 df = 2N_0$$

7. The bandwidth of a transmission channel is given as 1 MHz. What should be the minimum SNR at the output of the channel for the channel capacity to exceed 4 Mbps?

- a) 15** b) 4×10^6 c) $\log_2(4)$ d) e^4 e) e^{10} f) 400

$$C = W \log(1 + SNR)$$

$$SNR = 2^{C/W} - 1 = 2^{4/1} - 1 = 15$$

8. Two uncorrelated signals with 0V DC values and flat (upto 100 Hz) power spectral densities of 1 and 2 W/Hz respectively, are added. What is the total power of the resulting signal below 10 Hz ?

- a) 500 W b) 50 W c) 1 W d) 300 W **e) 60 W** f) 40 W

When the signals are uncorrelated and have 0 mean, the resulting power spectral density equals to the sum of their power spectral densities.

$$P_T = \int_{-10}^{10} (S_1 + S_2) df = \int_{-10}^{10} 3 df = 60$$

9. For an asymmetric binary channel input probabilities are $P(0) = 0.6$ and $P(1) = 0.4$. Error probabilities are given as 0.01 when 1 is sent and 0.02 when 0 is sent. What is the total probability of error?

- a) 0.14 b) 0.001 c) 0.02 d) 0.01 e) 0.03 **f) 0.016**

Apply the total probability theorem to the given BSC

$$P_e = P(0) \times P(1|0) + P(1) \times P(0|1) = 0.6 \times 0.02 + 0.4 \times 0.01 = 0.016$$

10. Input to the given LTI filter ($L=1$, $R=1$) is $x(t) = 2\cos(4\pi t + \pi/2)$. What would the output power spectral density be like?

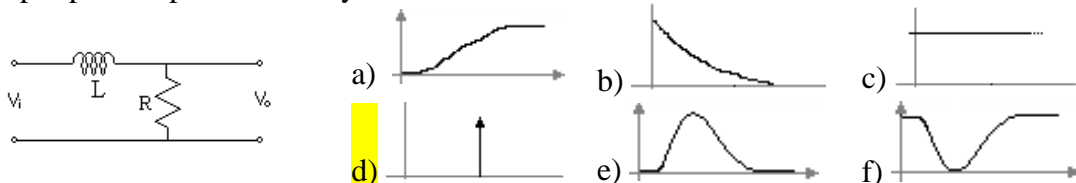

Linear systems' response is the sum of the responses for individual frequency components. Since the input has only one frequency component, output would obviously have a single frequency component.

11. X is a uniform random variable ranging between -1 and +1 and modeling the sample values taken from a periodic waveform. Which of the following can be the waveform that gives such a distribution?

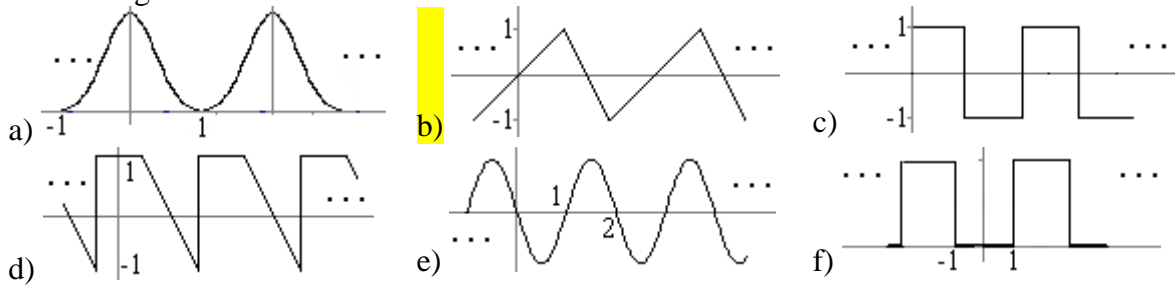

12. Input to the given LPF is white noise with $S(f) = 1$ and output noise power is 4 W. What is the noise-equivalent bandwidth of the filter?

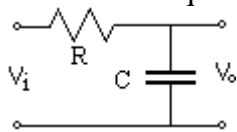

- a) RC
- b) 0.5
- c) $1/\pi$
- d) 2
- e) 1.0
- f) $2/\pi$

$$P_N = 4 = P_{neq}$$

$$H_{max} = 1 \text{ (from the filter)}$$

$$P_{neq} = 2 \int_0^{B_{neq}} H_{max}^2 df = 2H_{max}^2 B_{neq} = 2B_{neq} = 4 \text{ (given),}$$

$$\text{so the } B_{neq} = 2$$

13. The power of the following periodic signal is 0.25. What is the coefficient c ?

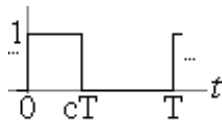

- a) 0.25
- b) 0.5
- c) 1.25
- d) $1/T$
- e) 0.125
- f) 2.0

$$P_s = 0.25 = \frac{1}{T} \int_0^T |x(t)|^2 dt = \frac{1}{T} \int_0^{cT} 1 df = \frac{cT}{T} = c$$

69. 05.06.2013 Final Exam (following 15 questions)

1. A BPSK signal modulates a carrier and the following spectrum is obtained. Determine the frequency of the carrier.



- a) 0.4 GHz
- b) 11.1 GHz
- c) 0.1 GHz
- d) 10.9 GHz
- e) 11.3 GHz
- f) 400 MHz

The frequency of the PSK carrier is seen to be $(11.3-10.9)/2=0.2$ GHz and the mixer (upconverter) frequency is $(11.3+10.9)/2=11.1$ GHz.

2. Which of the following is most-likely a PSK signal?

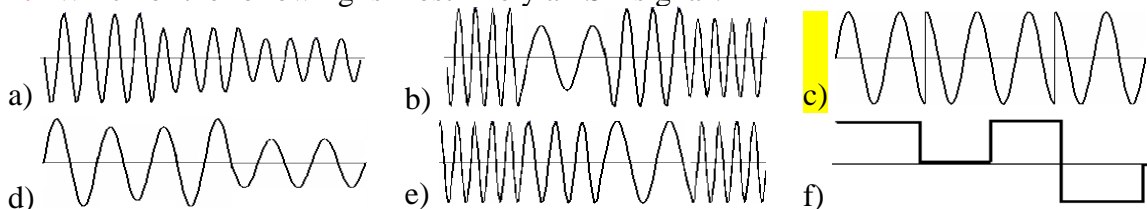

3. What is the entropy of the source that constantly generates the symbol stream "capulculuk" where the symbols are the characters? ($\log_2 0.2 = -2.32$, $\log_2 0.03 = -5.06$)
 a) 4.1 b) 4.2 c) 4.72 d) 1.71 e) -0.5 **f) 2.45**

The statistics of the source output needs to be calculated from the stream. We can easily find that $P(c) = 2/10$, $P(a) = 1/10$, $P(p) = 1/10$, $P(u) = 3/10$, $P(l) = 2/10$ and

$P(k) = 1/10$. Using $H = -\sum_{i=1}^4 P_i \log_2 P_i$ we find that

$$H = -0.2 \log_2 0.2 - 0.1 \log_2 0.1 - 0.1 \log_2 0.1 - 0.3 \log_2 0.3 - 0.2 \log_2 0.2 - 0.1 \log_2 0.1$$

$$H = -0.2 \log_2 0.2 - 0.3 \log_2 0.1 - 0.3 \log_2 0.3 = -0.2 \log_2 0.2 - 0.3 \log_2 0.03$$

$$H = 0.2 \times 2.32 + 0.3 \times 5.06 = 2.45 \text{ bits/symbol}$$

4. Which of the following is not a used synchronization name in communications?
a) frequency sync. b) bit sync. c) frame sync.
 d) carrier sync. e) phase sync. f) pn-code sync.

5. Which of the following is not a used multiple access method name in communications?
 a) time DMA b) frequency DMA c) space DMA
 d) polarization DMA **e) phase DMA** f) code DMA

6. Output of a symbol source is Huffman coded where the code {0,10,1100,1101,1110,1111} is assigned to symbols {e,n,p,g,u,i}. Decoder receives the stream 110001011011110010 and decodes into
 a) gunpen b) iguen c) unipig **d) penguin** e) guinei f) unipen

Inspecting the stream 110001011011110010 from left to right for substreams that exists in Huffman table, we find 1100.0.10.1101.1110.0.10 which decodes into "penguin".

7. Which of the following is not a method for multiple access to a shared media?
 a) Space Division Multiple Access **b) Phase Division Multiple Access**
 c) Frequency Division Multiple Access d) Code Division Multiple Access
 d) Polarization Division Multiple Access f) Time Division Multiple Access

8. What is the phenomenon called when the timing of a binary stream fluctuates in time?
 a) flotation b) inconsistency **c) timing jitter**
 d) timing leak e) off clocking f) synch lag

9. What is the fundamental frequency of the periodic waveform whose single period is

defined with
$$x(t) = \begin{cases} \sin(20\pi t), & 0 \leq t < 0.1 \\ 0, & 0.1 \leq t < 2 \end{cases} ?$$

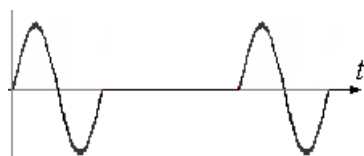

- a) 0.5** d) 0.1
 b) 20 e) 10π
 c) 10 f) 2

Since the period is 2, the fundamental frequency is $1/2=0.5$.

10. The decision threshold at the receiver of the following binary transmitter-channel-receiver system is 0. Assuming that the probability of sending 1 is 0.5, what should be the minimum value of A if the probability of error is needed to be less than 0.01?

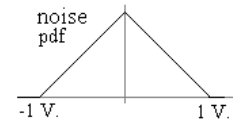
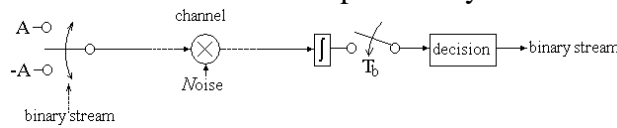

- a) 1.01 b) 0.1 c) 1.98 d) 1.5 **e) 0.99** f) 0.51

The probabilities of symbols are equal and noise pdf is symmetric, so the probability of error equals to the probability of error for one symbol according to the total probability theorem. P_e is the area shown in

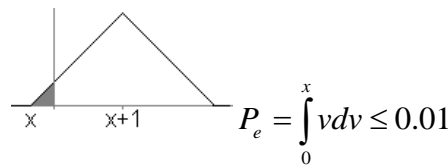

$$\int_0^x v dv = x^2 \leq 0.01 \Rightarrow x \leq 0.1 \Rightarrow A \geq 0.99$$

11. What is the output of the following system?

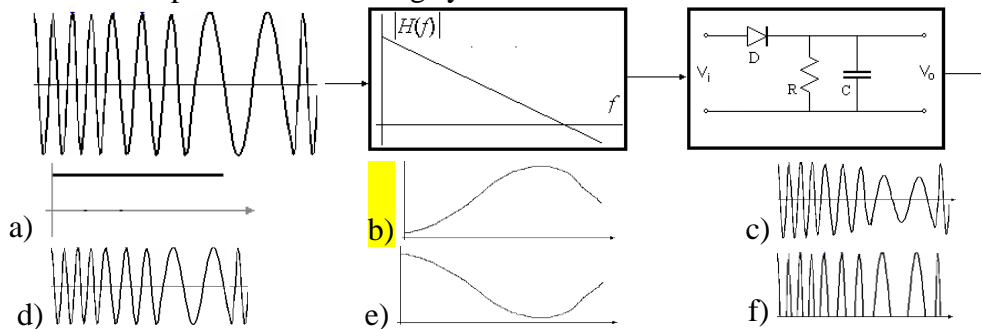

- a) **b)** c) d) e) f)

12. What is the main and common purpose of using Manchester and 8B10B coding?

- a) Transmission of data at higher rates b) Easier coding and decoding
c) Data protection and encryption d) Long range transmission
e) Compression and smaller bandwidth **f) DC balance and synchronization**

13. What is the noise equivalent bandwidth (B_{neq}) of the filter given?

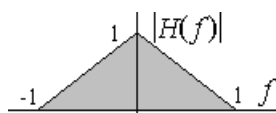

- a) 1 b) 2/3 c) $\pi/3$
d) 1/3 e) $2\pi/3$ f) 2

See 03.05.2008 2nd midterm solutions.

14. A periodic triangular waveform is uniformly quantized with the quantization levels (0.1, 0.3, 0.5, 0.7, 0.9). What is the pdf of quantization noise?

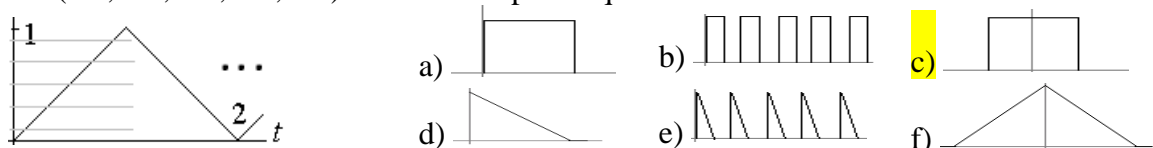

- a) b) **c)**
d) e) f)

Subdividing uniform pdf range into equal subregions, we get all equal and uniform pdfs in all subregions. Combining them up subsequently gives another uniform pdf.

15. What is the signal with 4.43 MHz used for, in a TV transmitter/receiver system?

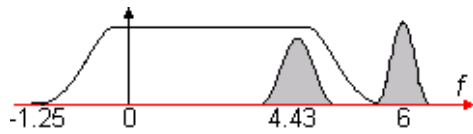

- a) synchronization
- b) horiz. sync.
- c) end of the frame
- d) left channel sound.
- e) color signal
- f) brightness

70. 20.06.2013 Final Makeup Exam (following 3 questions)

1. The binary stream “11011011100111010100101001110101111010011110101001” is statistically representative of a binary information source X. A binary antipodal signaling of -1 V and +1 V is used to transmit the output of the source through a binary symmetrical channel under AWGN with $\sigma=1$. What would be the probability of error when a decision threshold of 0 V is used at the receiver?

Use the approximation of

$$\text{erf}(x) \approx 1 - \frac{1}{(1 + a_1x + a_2x^2 + a_3x^3 + a_4x^4)^4}$$

where $a_1 = 0.278393$, $a_2 = 0.230389$, $a_3 = 0.000972$, $a_4 = 0.078108$ for

$$\text{erf}(x) = \frac{2}{\sqrt{\pi}} \int_0^x e^{-t^2} dt.$$

The probability of error when 0 is sent $P(1|0) = \int_{-\infty}^0 \frac{1}{\sqrt{2\pi}\sigma} e^{-\frac{(x-m)^2}{2\sigma^2}} dx = \int_1^{\infty} \frac{1}{\sqrt{2\pi}} e^{-\frac{x^2}{2}} dx$.

Letting $t = \frac{x}{\sqrt{2}} \Rightarrow dt = \frac{dx}{\sqrt{2}} \Rightarrow dx = \sqrt{2}dt$ and $t^2 = \frac{x^2}{2}$, for $x=1$ $t = \frac{1}{\sqrt{2}}$

So the integral becomes $P(1|0) = \frac{1}{\sqrt{\pi}} \int_0^{\frac{1}{\sqrt{2}}} e^{-t^2} dt$ and $\text{erf}(\frac{1}{\sqrt{2}}) = 1 - 2P(1|0)$

Using the approximation,

$$\text{erf}(\frac{1}{\sqrt{2}}) \cong 1 - \frac{1}{(1 + 0.278 \times 0.707 + 0.23 \times 0.5 + 0.001 \times 0.35 + 0.078 \times 0.25)^4} = 0.681.$$

We have

$$P(1|0) = (1 - \text{erf}(\frac{1}{\sqrt{2}}))/2 = 0.16.$$

Since the channel is symmetric, the probabilities of individual symbols does not matter and $P_e = 0.16$

2. Draw the frequency spectrum of BPSK signal where a 10 MHz carrier is modulated by a 10 Mbps binary stream. Assume that the carrier is a perfectly sinusoidal and the binary stream is perfectly random.

Given the magnitude frequency spectrum of two inputs of the modulator as shown below, we find the following spectrum using the modulation property of the Fourier Transform.



3. Given the normalized TV signal spectrum what is the center frequency (f_c) and bandwidth (BW) of the BPF (band-pass filter) for the following commercial TV transmitter.

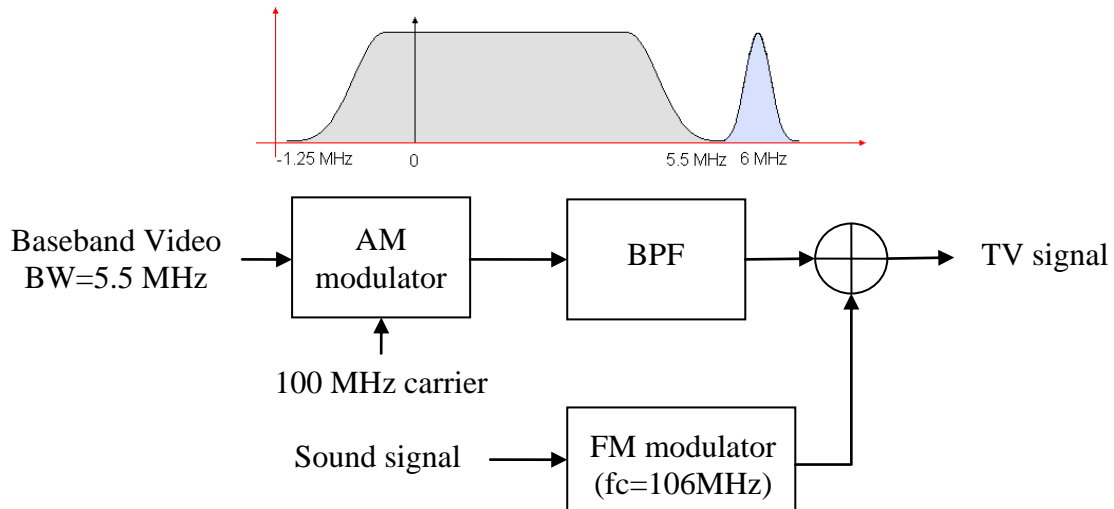

$BW = 5.5 + 1.25 = 6.75 \text{ MHz}$
 $f_c = 100 + BW/2 = 103.375 \text{ MHz}$

71. 20.03.2014 1st Midterm Exam (following 11 questions)

1. A baseband signal modulates a carrier and a conventional AM signal is obtained. The spectrum of the modulated signal is given below. What is the bandwidth of the baseband signal?

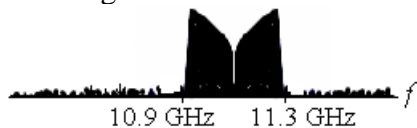

- a) 400 MHz
b) 200 MHz
 c) 0.21 GHz
 d) 0.4 GHz
 e) 11.1 GHz
 f) 11.3 GHz

2. Which of the following is most-likely an ASK signal?

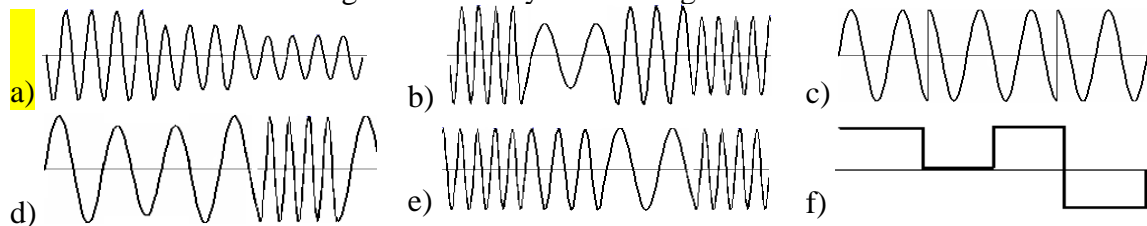

3. What is the second harmonic frequency of the following periodic waveform?

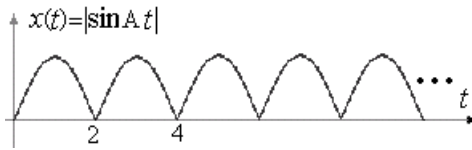

- a) 0.25 d) 2A
 b) $A/2\pi$ e) 1
 c) 2 f) 0.5

4. The section shown as Line Information in the picture below determines the color and intensity of the current location on the currently scanned line of a TV signal. The running average of this signal determines the intensity of the current scan location and is called ...

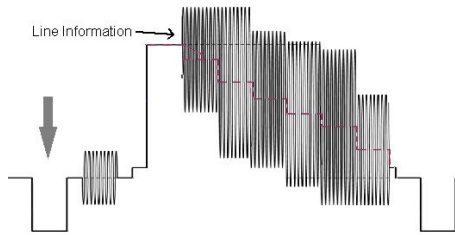

- a) Horizontal synchronization
 b) Chrominance
 c) Color burst
 d) Luminance
 e) Amplitude Modulation
 f) Color mode

5. Input to the given LTI filter ($L=1$, $R=1$) is additive white Gaussian noise. What would the output power spectral density be like?

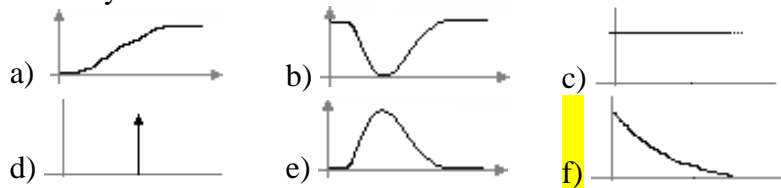
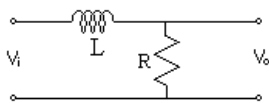

6. What should be the period T for the signal power to be 1 for the following periodic signal?

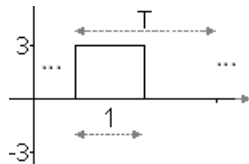

- a) 3 d) 2
 b) 27 e) 3π
 c) 9 f) not possible

7. What would be the spectrum of the modulated signal if the message signal whose spectrum is given DSB-SC-AM modulates a carrier with $f=3$?

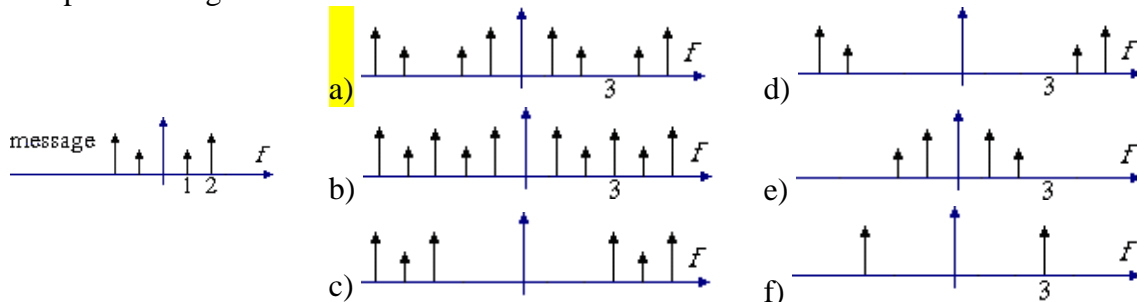

8. A baseband message signal spectrum is fed through the system given. What is the output signal spectrum when $\omega_c = 3\pi$?

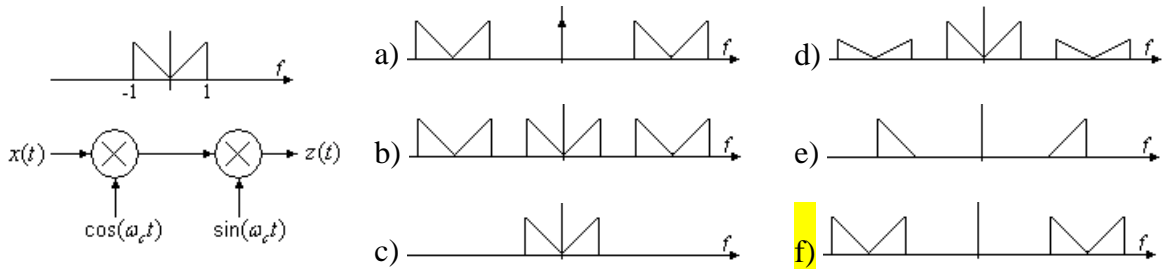

9. A linear filter and input signal frequency characteristics are given. What is the output signal power?

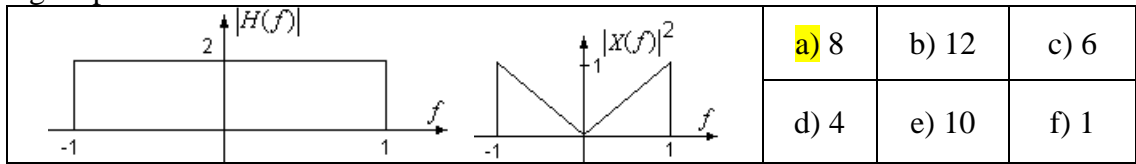

10. A 12Hz carrier is LSB modulated with a tone signal and $A\sin(22\pi t + \theta)$ obtained (A, B, θ and φ are arbitrary constants). What would be the modulated signal if USB AM modulation were used instead?

- a) $\sin(22\pi t + \varphi) + 2\cos(26\pi t)$ b) $B(\sin(11\pi t + \varphi) + \sin(13\pi t + \varphi)) + \cos(12\pi t + \varphi)$
 c) $B(\sin(22\pi t + \theta) + \sin(24\pi t + \theta))$ d) $B\cos(22\pi t + \varphi) + A$
 e) $B\sin(26\pi t + \varphi)$ f) $B(\sin(22\pi t + \varphi) + \sin(26\pi t + \varphi)) + A\cos(24\pi t)$

11. Which modulation technique is illustrated in the following figure?

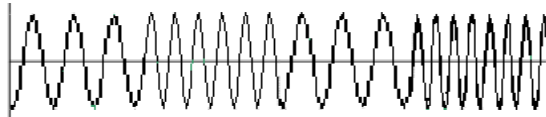

- a) AM d) QPSK
 b) PSK e) ASK
 c) FSK f) VSB

72. 08.05.2014 2nd Midterm Exam (following 11 questions)

1. A noisy transmission line is driven by a TTL driver where logic-L=0V and logic-H=5V. The line receiver has a threshold of 1.5V, that is, when the input is below 1.5V the signal is assumed to be logic-L, otherwise it is logic-H. The pdf of noise is given below. What is the probability of decision error when the probability of sending logic-L is 0.6.

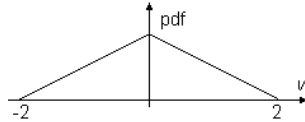

- a) 0.075 d) 0.15
 b) 0.125 e) 0.25
 c) 0.4 f) 0.5

The situation is illustrated below where the probability of receiving logic-H when logic-L is sent is marked as gray triangle area between 1.5 and 2V.

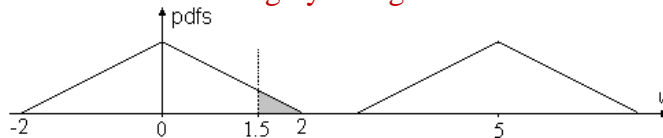

The marked area is $A = 0.5 \times 0.25 / 2 = 0.0625$. Since the probability of sending logic-L is 0.6, the error contribution by sending logic-L will be $P_L = 0.6 \times 0.0625 = 0.0375$. No error will be made by sending logic-H, therefore the prob. of error per symbol (total prob.theo) is $P_e = 0.0375$ (since this answer is not in the choices, this question is excluded from evaluation)

2. A signal with uniform pdf between 0 and 10V is uniformly quantized with quantization levels of 0.5, 1.5, 2.5, ..., 9.5V. What would the pdf of quantization noise be like?

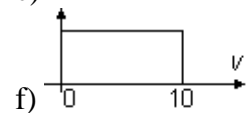
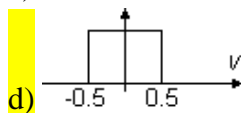
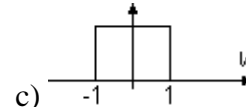
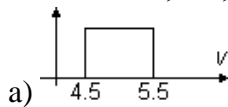

3. Output of a source that generates {u,k,t,c,i} symbols is Huffman coded. The symbols {u,k,t,c,i} are assigned the code {0,10,110,1110,1111} respectively. What is the decoder output when it receives the stream 10011001110010 ?

- a) kicikucu b) kuku c) uctuk d) cikcickik e) tiktuctuu **f) kutucuk**

Rewriting the stream as 10.0.110.0.1110.0.10 by separating it into unique substreams from left to right, we get k.u.t.u.c.u.k.

4. What is the average information per source symbol for the source described with the ensemble (A, z) where $A = \{00, 01, 10, 11\}$ and $z = \{0.5, 0.25, 0.125, 0.125\}$?

- a) 2.0 **b) 1.75** c) 2.25 d) 1.0 e) 0.5 f) 4.0

5. A baseband signal is under the effect of some white noise. Both signal and noise spectrums are given below. What would be the optimum ideal filter characteristic in order to minimize the effects of noise (i.e. improve SNR)?

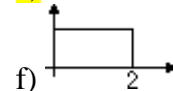
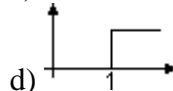
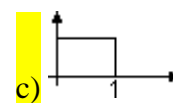
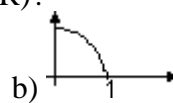
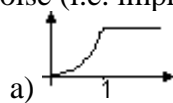
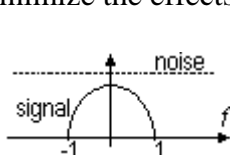

For optimal noise rejection we need to pass all signal components and no further. Since it is stated that it should be an ideal filter, the answer is c. Better filters might exist for better SNR, however. Unless the detection properties of the actual signal are given we cannot improve further.

6. Spectrum of a signal is given below. Assuming that $C(f) = c_1$ and $N(f) = c_2$ where c_1 and c_2 are constants, which of the following pairs would be a working preemphasis-deemphasis filter pair $(P(f), D(f))$?

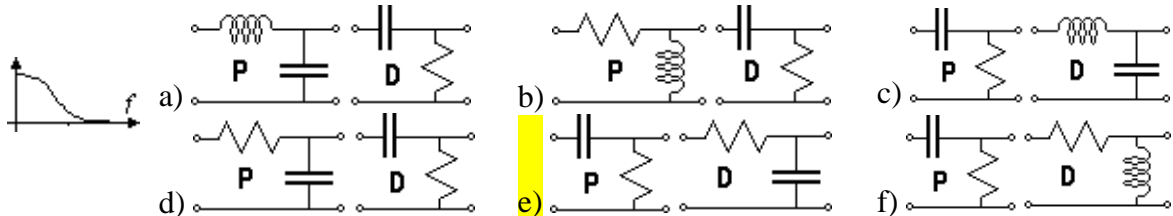

Since the signal is a low-pass and the channel is flat and the noise is white, we should amplify high frequencies at the transmitter and attenuate them at the receiver. Therefore, we need to have HP-LP pair. The choice e will do it.

7. In a Gray-coded 8-ary PSK communication system, the symbol error rate is 0.01. What would be the bit error rate (BER)?
 a) 3.3×10^{-3} b) 0.01 c) 0.03 d) 0.08 e) 1.25×10^{-3} f) 1.0×10^{-8}

Each symbol carries 3 bits in 8-ary PSK. A symbol error means an incorrect decision of reception of the neighboring symbols. Since the constellation is Gray-coded the neighboring symbols have 1 bit difference. Hence, 1 symbol error means 1 bit error. Therefore, the bit error is symbol error divided by 3; $0.01/3 = 3.3 \times 10^{-3}$.

8. What would be the frequency spectrum like for the binary FSK signal an example waveform of which is given for frequencies f_1 and f_2 ?

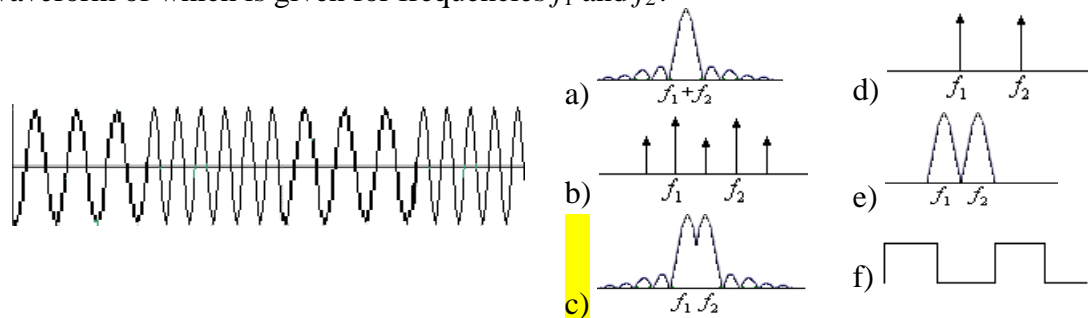

Considering that the FSK can be thought of a linear sum of 2 ASK signals with different carrier frequencies, the spectrum of FSK will be the sum of the spectrums of those. Except the special cases of carrier frequency selections, the spectrum will be the sum of two *sincs*.

9. A ternary (3 levels) communication channel with additive noise is given. The 3 values representing 3 symbols transmitted are $-A$, 0 and $+A$ where A is a constant value. What should be the value of A for minimum channel error when the pdf of noise is as given below?

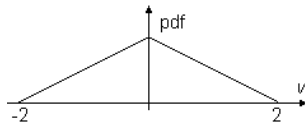

- a) 2
b) 3
c) 1.5
d) 4
e) 0.5
f) 8

Three cases of selection of A are illustrated in the following figure.

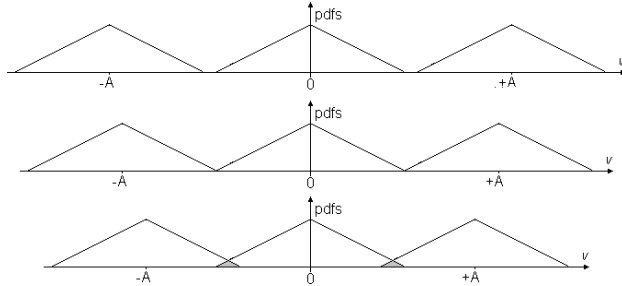

The case in the middle is when A is the smallest and has zero probability of error at the same time. Therefore A should be 4.

10. $z(t)$ is a QPSK modulated signal and $N(t)$ is white noise with spectral density N_0 . The

filter's transfer function is $H(f) = \begin{cases} 0.1, & |f| \leq 1 \\ 0, & \text{otherwise} \end{cases}$. What is the output noise power?

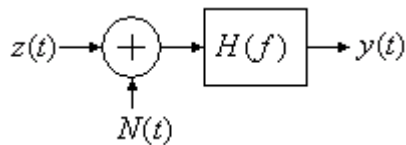

- a) $0.1 N_0$
b) 0.2
c) $0.04 N_0^2$
d) 1
e) $0.02 N_0$
f) 2

The system is linear; therefore the output noise power can be calculated separately.

$$P_o = \int_{-\infty}^{\infty} S_o(f) df = 2 \int_0^{\infty} S_i |H(f)|^2 df = 2 \int_0^1 N_0 |0.1|^2 df = 0.02 N_0$$

11. A periodic signal is given below. Which one of the following functions best represent the probability density function of the given periodic signal?

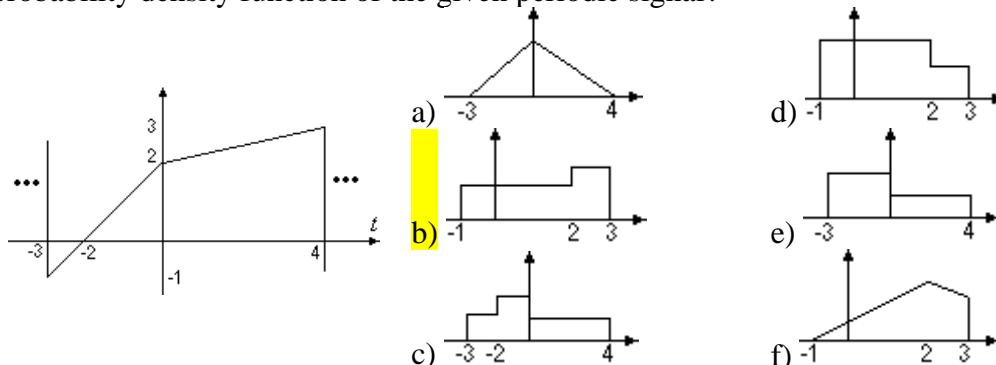

Linear portions add uniform partial distributions to the whole. We have two linear regions, meaning two uniform parts in pdf; -1 to 2 and 2 to 3 . Since the range $(-3,0)$ is shorter than the range $(0,4)$, the pdf should look like the one in c. Actual pdf values can be calculated but none of the answers have actual prob. values; not necessary here.



73. 21.05.2014 MakeUp Exam (following 4 questions)

A binary communication system that uses antipodal signaling (+A, -A) is given. Assume that perfect synchronization is always achieved, i.e. decision samples are taken with perfect timing (which is *the root problem* in real systems).

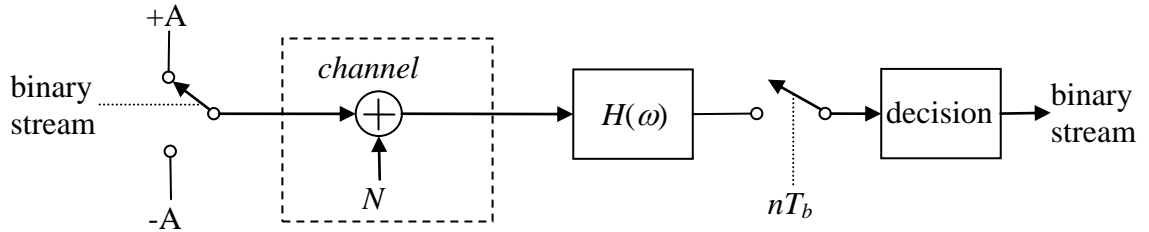

1. The noise pdf is given below. Assume that $H(\omega)=1$. Determine the smallest A for the probability of detection error to be $P_e < 0.01$. (hint: when there is no matched filter, the detection only relies on the noisy sample value at the decision instant)

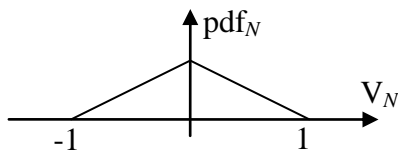

Solution

Since the noise pdf is symmetric $P(0|1)=P(1|0)=P_e$. The area marked in the figure below equals to the probability of incorrect decision when A is sent (eg. $P(0|1)$).

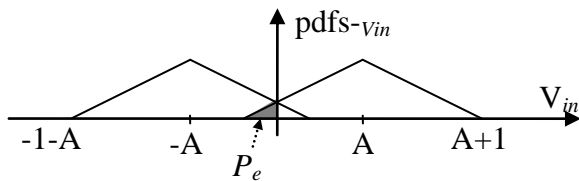

$\frac{x^2}{2} = P_e$ (area of the triangle) and $P_e < 0.01$. Thus, for the = case, $x = \sqrt{0.02} \cong 0.14$.

From here, $A_{\min} = 1 - 0.14 = 0.86$.

2. In order to improve detection performance we either need to have a matched filter or waveform correlator before decision samples. Determine the response of the matched filter to the symbol waveform(s) when a matched filter $H(\omega)$ is used.

A causal matched filter impulse response for a given waveform can be obtained by flipping the waveform horizontally and shifting it until it becomes causal (whole thing is on the positive time axis). Doing this we get $h(t)$ given in the figure below. $h(t) * \psi(t)$ convolution results in something like V_o shown in the figure.

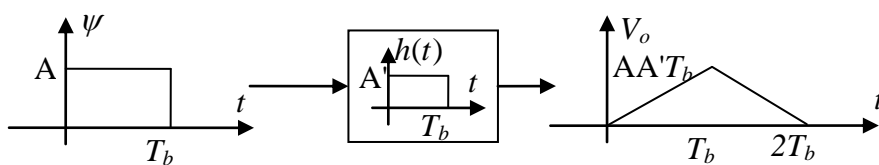

3. Calculate the probability of decision error P_e when the matched filter is used.

It is assumed that V_o is measured at the nT_b instants. At that time the signal value at the filter output is $AA'T_b$. Since noise is uncorrelated its value at that instant is only amplified by A' ($A'=1$). The new condition is illustrated in the following figure.

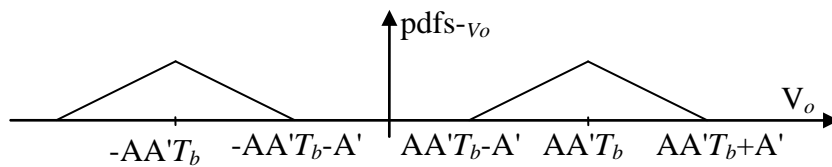

Unless $AA'T_b-A' < 0$ the probability of detection error will be $P_e=0$. This means $AT_b > 1$ is required. In real life, when the noise is Gaussian, $P_e=0$ is not possible since our example noise here is hypothetical and magnitude-limited. But the example clearly shows how matched filters help improve detection capability. In Gaussian noise case, the error rate will be reduced but will not be zero.

4. What should be the energy of the waveform(s) in order to make $P_e=0$ when all receiver parameters are optimal (i.e. $H(\omega)$ is optimally determined and sampling times are perfect)

$$E = \int_0^{T_b} |A|^2 dt = |A|^2 T_b$$

If $AT_b > 1$ condition is satisfied at the limit ($AT_b=1$) then $A=1/T_b$. Using this,

$$E \geq \left| \frac{1}{T_b} \right|^2 T_b = \frac{1}{T_b} .$$

It is nice & natural to note here that in order to increase bit-rate of the transmission one has to increase energy for the same BER (bit error rate) performance. Just increasing the pulse levels (voltage) may not always be possible because of the media limitations. We may have to design pulse shapes for better utilization of available frequency band. We should also employ error correcting codes (ECC). When all such resources are used up for the best performance we will be approaching the channel capacity.

74. 28.05.2014 Final Exam (following 14 questions)

For the following 4 questions: A binary communication system that uses antipodal signaling (+A, -A) is given. Assume that perfect synchronization is always achieved, i.e. decision samples are taken with perfect timing (which actually is the main task in real systems).

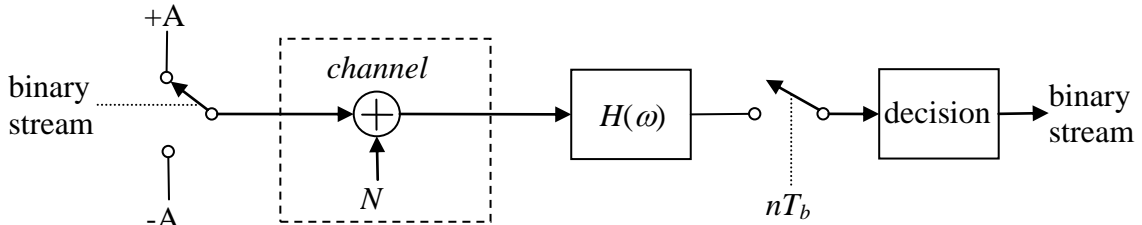

(for the solutions of these 4 questions see [MakeUp Exam-21.05.2014](#))

1. The noise pdf is given below. Assume that $H(\omega)=1$. Determine the smallest A for the probability of detection error to be $P_e \leq 0.01$. (hint: when there is no matched filter, the detection only relies on the noisy sample value at the decision instant)

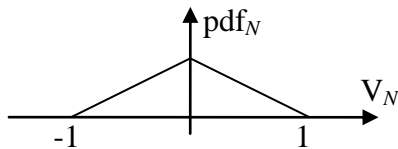

- a) 0.86
- b) 1.0
- c) 2.0
- d) 0.52
- e) 0.27
- f) 1.14

2. In order to improve detection performance we either need to have a matched filter or waveform correlator before decision samples. Determine the response of the matched filter to the symbol waveform(s) when a matched filter $H(\omega)$ is used.

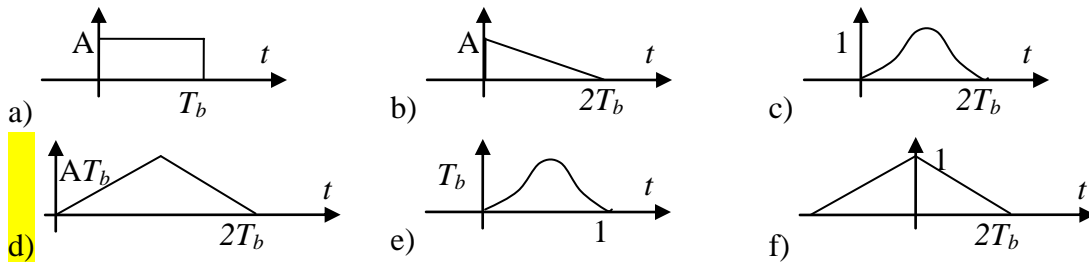

3. What is the probability of decision error P_e when the matched filter is used and $AT_b = 1$?

- a) 0.01
- b) 0.0
- c) 0.02
- d) 0.1×10^{-3}
- e) 0.001
- f) 0.052

4. What should be the minimum energy of the pulse(s) in order to make $P_e=0$ when $H(\omega)=1$?

- a) A/T_b
- b) A^2
- c) 1
- d) AT_b
- e) $1/T_b$
- f) $A^2 T_b^2$

(the following are independent of the first 4 questions)

5. The periodic waveform given is uniformly quantized with the quantization levels (-2,-1,0,1,2,3). What is the pdf of the quantization noise?

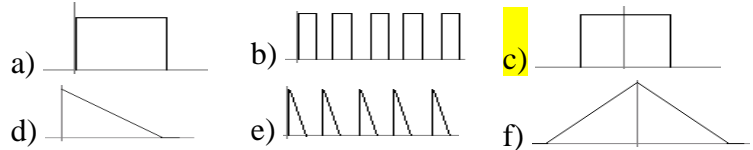
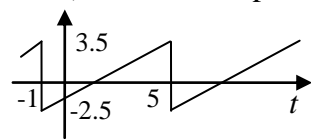

6. Which of the following is the most important reason for rf-modulation?

- a) Message signal won't go anywhere otherwise
- b) We save energy by modulating carrier
- c) Because it is a linear process and easy
- d) It is easier to demodulate rf signal
- e) rf-modulation protects signal from noise
- f) Sharing the transmission media

7. An information source whose ensemble is (A, z) where $A = \{a, b, c, d\}$ and $z = \{0.6, 0.2, 0.1, 0.1\}$ is given. What would be the average code length when the source output is Huffman coded?

- a) 1.57
- b) 1.5
- c) 2.0
- d) 1.6
- e) 1.81
- f) 2.25

Solution

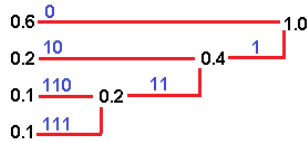

$$L_{avg} = \sum_{i=1}^4 l_i p_i = 1 \times 0.6 + 2 \times 0.2 + 3 \times 0.1 + 3 \times 0.1 = 1.6$$

8. What is the length of the m-sequence generated by the shift-register generator described by $[8, 4, 3, 2]$?

- a) 4
- b) 256
- c) 255
- d) 16
- e) 15
- f) 31

Solution

Since this is a shift register with 8 delay elements $L = 2^8 - 1 = 255$

9. A baseband signal whose spectrum is given is multiplied twice by a carrier whose frequency is higher than the bandwidth of the baseband signal. What would be the spectrum of the output signal?

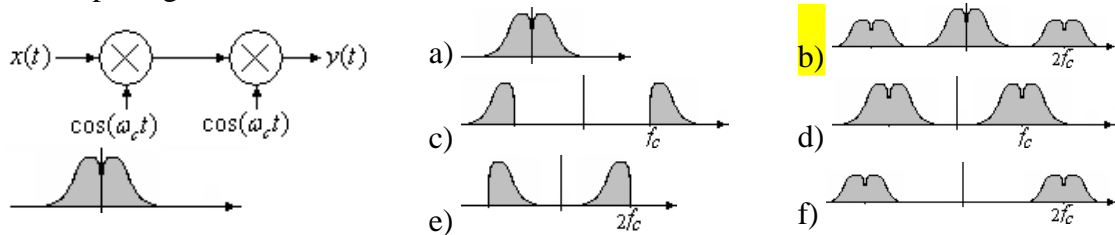

Solution

$$y(t) = x(t) \cos^2(\omega_c t) = x(t) (1 - \cos(2\omega_c t)) / 2 = x(t) / 2 - x(t) \cos(2\omega_c t) / 2$$

using the modulation property of FT (i.e. $f(t)g(t) \Leftrightarrow \frac{1}{2\pi} (F(\omega) * G(\omega))$) for the second term

we get $x(t) \cos(2\omega_c t) \Leftrightarrow \frac{1}{2} X(\omega - 2\omega_c) + \frac{1}{2} X(\omega + 2\omega_c)$. Summing the mag-FT's of two terms we get a spectrum like shown in b).

10. What would the output power spectral density of the following LTI circuit be like when input is white Gaussian noise?

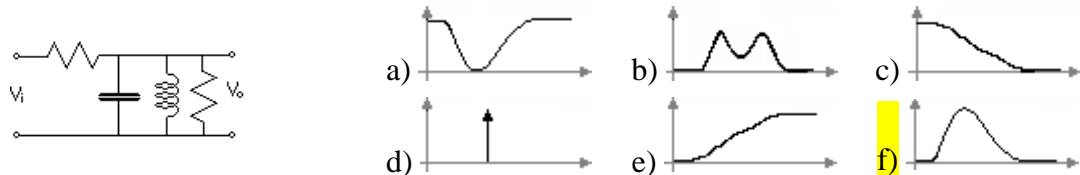

Solution

LC forms a parallel resonator, showing high impedance at the resonance frequency and neighborhood. Therefore we get a band-pass filter out of this voltage divider.

11. What is the modulation type when both amplitude and phase assume finite number of values as exemplified in the figure?

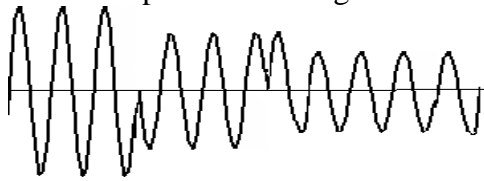

- a) PSK
- b) ASK
- c) APM
- d) QAM
- e) QPSK
- f) QPM

12. Which of the following is not a method for multiple access to a shared media?

- a) Phase Division Multiple Access
- b) Space Division Multiple Access
- c) Frequency Division Multiple Access
- d) Code Division Multiple Access
- e) Polarization Division Multiple Access
- f) Time Division Multiple Access

13. (Lab question) Given the message signal and the carrier below, draw an illustration of just a little bit over-modulated AM wave.

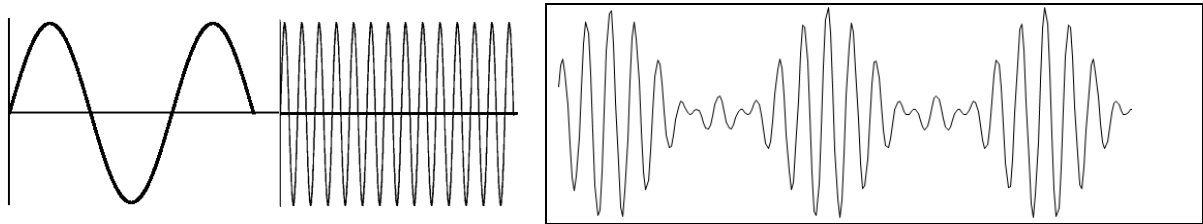

75. 19.06.2014 Final Exam Make-Up

A binary communication system that uses antipodal signaling (+A, -A and $P(0) = P(1)$) is given. Assume that perfect synchronization is always achieved, i.e. decision samples are taken with perfect timing (which is the root problem in real systems).

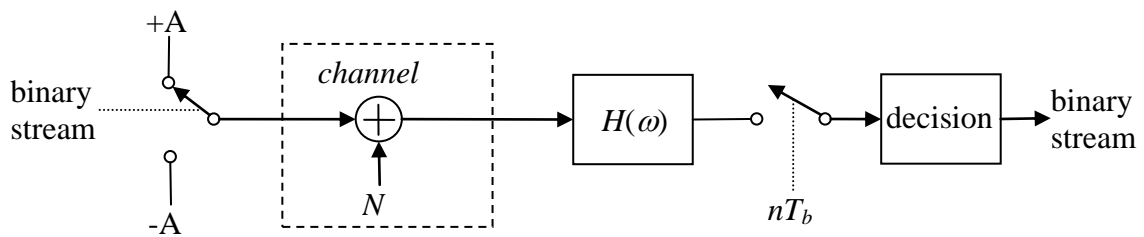

1. The uncorrelated noise has flat spectrum and its pdf is $\frac{1}{2}e^{-|x|}$ as drawn below. Assume that $H(\omega)=1$. Determine the smallest A for the probability of detection error to be $p_e \leq 0.01$. (hint: when there is no matched filter, the detection only relies on the noisy sample value at the decision instant)

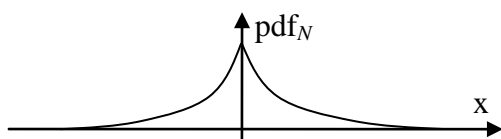

Solution

Since the noise pdf is symmetric $P(0|1)=P(1|0)=P_e$. The gray area marked in the figure below equals to the probability of incorrect decision when A is sent (eg. $P(0|1)$).

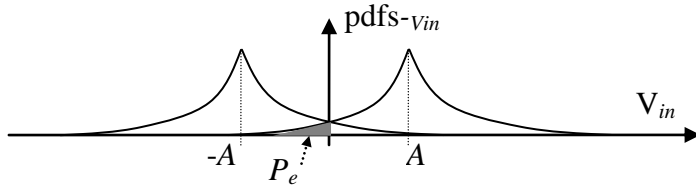

$$P_e = \int_{-\infty}^0 \frac{1}{2} e^{-|v-A|} dv = \frac{1}{2} \int_A^{\infty} e^{-v} dv \quad (\text{area under the curve}) \quad \text{and} \quad P_e < 0.01. \quad \text{Thus, for the equality case,}$$

$$0.01 = \frac{1}{2} \int_A^{\infty} e^{-v} dv = -\frac{1}{2} e^{-v} \Big|_A^{\infty} = \frac{1}{2} e^{-A}. \quad \text{From here} \quad A = \ln 50 \approx 3.9 \leq A_{\min}$$

2. In order to improve detection performance we use either a matched filter or waveform correlator before sampling for decision. Determine the response of the matched filter to the symbol waveform(s) when the matched filter is used.

Solution

A causal matched filter impulse response for a given waveform can be obtained by flipping the waveform horizontally and shifting it until it becomes causal (whole thing is on the positive time axis). Doing this we get $h(t)$ given in the figure below. $h(t) * \psi(t)$ convolution results in something like V_o shown in the figure.

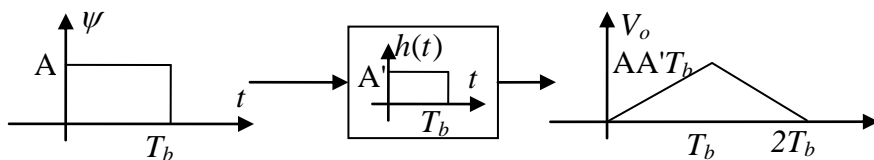

3. Calculate the probability of decision error P_e in terms of other parameters (not a specific number) when the matched filter is used.

Solution

It is assumed that V_o is measured at the nT_b instants. At that time the signal value at the filter output is $AA'T_b$. Since noise is uncorrelated, its value at that instant is only amplified by A' and A' will cancel out in the performance calculations. Since A' will have no effect on detection performance we can assume $A'=1$ and simplify calculations. The new situation is illustrated in the following figure.

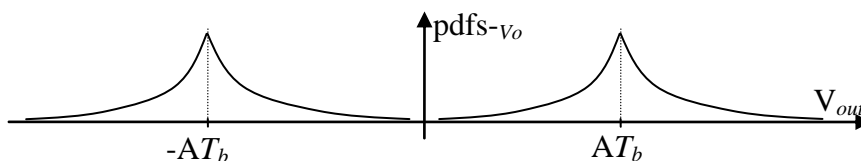

This time the area under the curve that represents the decision error is expected to be much smaller depending on the amplification constants. Using the same integral formula

$$P_e = \int_{AT_b}^{\infty} \frac{1}{2} e^{-v} dv = \frac{1}{2} e^{-AT_b}$$

This result clearly shows that, in order to improve the detection performance, we either increase the signal energy (voltage A) or increase the bit duration (slow down) or both, apart from the synchronization requirements.

4. Draw the P_e vs bitrate graph for the given noise and perfect synchronization.

Solution

Since the rate $r = 1/T_b$ we have $P_e(r) = \frac{1}{2} e^{-A/r}$. Drawing this for $r > 0$, we get

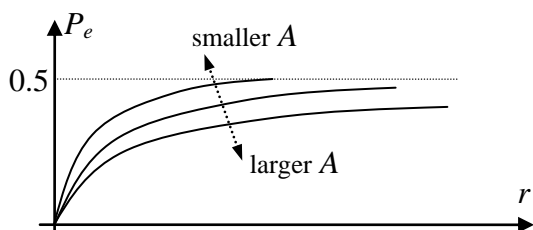

It is obvious from the graph that for the same BER (bit error rate) performance we need to increase A when the bit rate is increased.

5. A baseband signal whose bandwidth is B and peak value is m will be transmitted with conventional AM at $2f_c$ center frequency. The following items are available. Design the circuit. (for filters f_o : center frequency, BW : bandwidth)

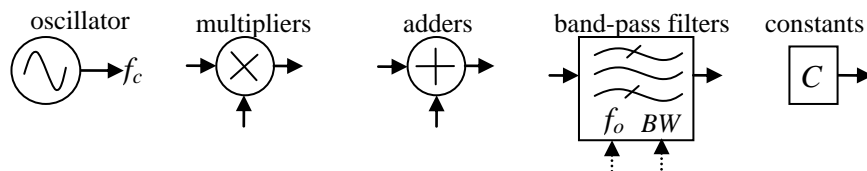

Solution

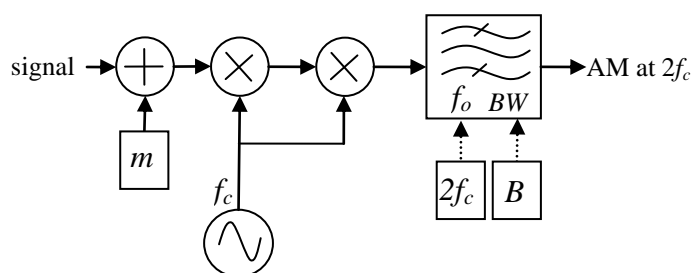

$$y_o(t) = (x(t) + m) \cos^2(2\pi f_c t) = (x(t) + m) \left(\frac{1}{2} + \frac{1}{2} \cos(4\pi f_c t) \right)$$

$$y_o(t) = \frac{1}{2} x(t) \cos(4\pi f_c t) + \frac{1}{2} m \cos(4\pi f_c t) + \frac{1}{2} x(t) + \frac{1}{2} m$$

First 2 terms make up the AM signal we want, so a bandpass filter is needed with center frequency of $2f_c$ and bandwidth of B .

76. 08.04.2015 Midterm

1. Which of the following can be the magnitude spectrum of a periodic signal with period $T=0.25$ and time average $Avg=0$?

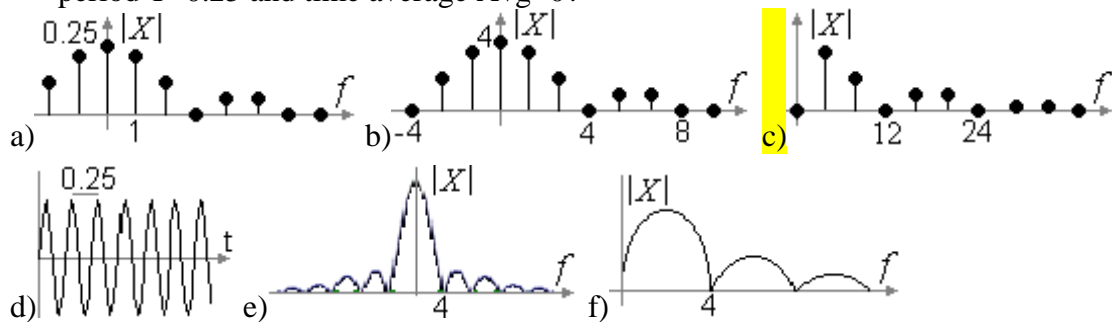

(note: above is the original question, but T is incorrectly given as $T=0.4$, therefore the question will be excluded from exam ☹)

Solution

Since the signal is periodic the fundamental frequency is $f=1/T=4$. The answer is c in which the DC value is 0 (as hinted with $Avg=0$ in the question.)

2. When a DSB-SC-AM short-wave radio station broadcast a tone test signal a spectrum analyzer measured the following. What are the frequencies of the carrier & tone signals?

| | | | |
|--|---------------|-------------------|----------------|
| | a) 9840, 800 | b) 9839.2, 1600 | c) 9839.2, 800 |
| | d) 9840, 1600 | e) 9839.2, 9840,8 | f) 1600, 800 |

3. Given the partial waveform, what do you think the constellation diagram would be?

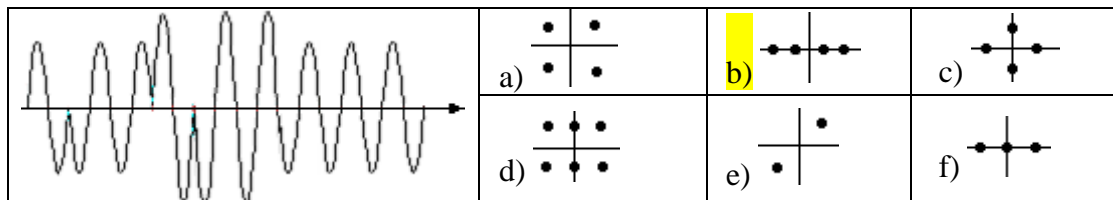

4. Stereo-FM uses an approach illustrated below. What are the outputs $y(t)$ and $z(t)$?

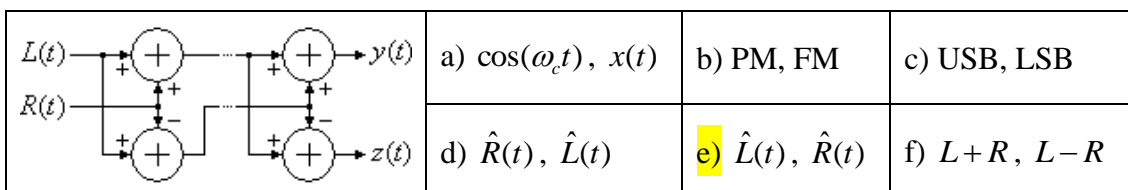

5. Given the pdf of noise added to a binary antipodal signal with rectangular pulse amplitude of 0.8, what is the probability of decision error when the decision threshold is selected according to ML, but $p(1) = 0.4$?

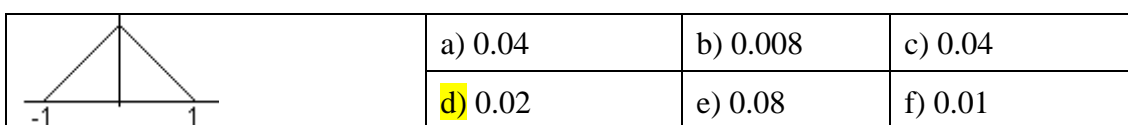

Solution

ML threshold assumes equal symbol probabilities and is at the halfway between symbols.

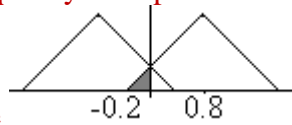

Marked area in the figure gives the error when 0.8 is sent which is the same when -0.8 is sent. Using area of a triangle formulation we find that the answer is 0.02. (One may attempt to calculate the average error using total probability theorem, but since the areas are the same he/she would find the same answer).

6. A voice signal has prob. dist. of $f_x(x) = 0.5e^{-|x|}$. What is $p(|x| > 1)$?
 a) $1/e$ b) $2/e$ c) $1/2$ d) $\ln(2)$ e) 0.05 f) $\log(e)$

Solution

The marked area in the following figure is the probability asked.

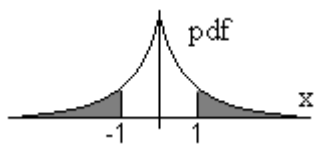

$$p(|x| > 1) = 2 \int_1^{\infty} 0.5e^{-|x|} dx = -e^{-x} \Big|_1^{\infty} = 0 + e^{-1} = 1/e$$

7. The following FSK signal has three distinct frequencies. It is applied to frequency-amplitude converter. What would be the output of the AM demodulator?

| | |
|----|----|
| a) | d) |
| b) | e) |
| c) | f) |

Solution

Frequency-amplitude converter given generates higher amplitudes for higher frequencies. AM demodulator input should be

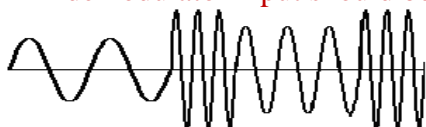

Therefore the output after the AM demodulator should be as shown in answer d.

8. A baseband signal is USB-AM (with some carrier) modulated a carrier and the following spectrum is obtained. What is the most probable baseband signal?

| | | |
|--|---------------------------|------------------------------------|
| | a) $\sin(2t) + 2\cos(2t)$ | b) $\sin(t) + \cos(2t) + \cos(3t)$ |
| | c) $\sin(2t) + 2\cos(3t)$ | d) $\cos^2(t) + \cos(t)$ |
| | e) $\sin(9t) + \cos(11t)$ | f) $\sin(t) + \cos(3t)$ |

9. Name the numbered components of color video signal shown below, in the correct order.

| | | |
|--|--|---|
| | a) horiz. pulse, video, intensity | b) frame-start, rgb-info, frequency |
| | c) carrier sync, color carrier, voice data | d) horiz. sync, vert. sync, color-intensity |
| | e) vert. sync, sound, teletext | f) horiz. sync, color burst, line of video |

10. What is the minimum sampling frequency for the signal whose spectrum is given, for the complete reconstruction of the signal, according to the Nyquist criterion?

| | | |
|--|-------|-------|
| | a) 30 | b) 20 |
| | c) 12 | d) 60 |
| | e) 22 | f) 40 |

Solution

Nyquist criterion requires that the sampling frequency must be higher than the twice of the bandwidth of the sampled signal for perfect reconstruction. The bandwidth of the signal is $15-4=11$. Therefore, the sampling frequency must be at least 22 (plus epsilon).

11. How many bits are transmitted per phase shift in an M-ary PSK system?

- a) M b) 2^M c) M^2 d) 2 e) 8 **f) $\log_2 M$**

12. In the following system, $x = \sin(t)$, $y = \cos(2t)$ and $z = \cos(4t)$ are given. What would be the most probable filter $H(f)$ characteristics if the output magnitude spectrum is as given in the figure?

| | | | |
|--|----|------------|----|
| | a) | b) | c) |
| | d) | e) | f) |

77. 15.04.2015 Quiz

A uniform random variable is applied to a linear function as shown in the figure. What is the output probability distribution function? Let $a=2$, $b=1$.

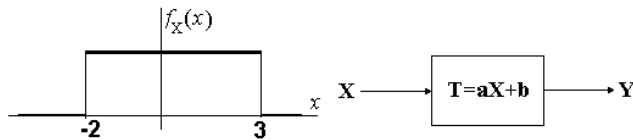

Solution

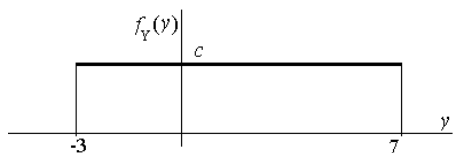

$$y_{\min} = 2x_{\min} + 1 = -3, \quad y_{\max} = 2x_{\max} + 1 = 7$$

$$c = 1/(b' - a') = 0.1$$

78. 03.06.2015 Final Exam

For the following 4 questions: A binary communication system that uses antipodal signaling (+A, -A) is given. Assume that the decision samples are taken with perfect timing and channel has a flat frequency response ($C(\omega)=1$).

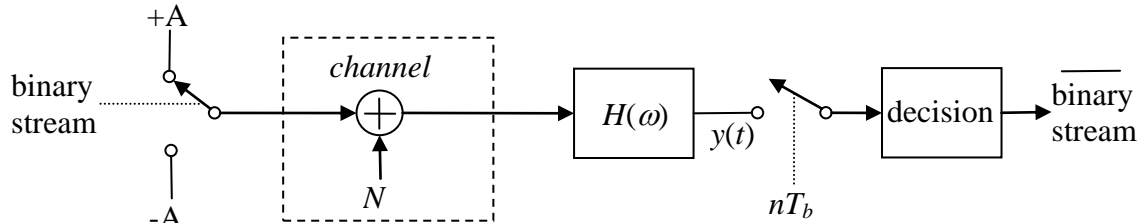

1. The noise pdf is given below as $\frac{1}{2}e^{-|V_N|}$. Determine the smallest A for the probability of detection error to be $P_e \leq 0.01$ when the matched filter $H(\omega)=1$ (hint: when there is no matched filter, the detection relies only on the noisy sample value at the decision instant).

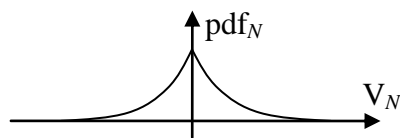

- a) 0.86 d) 3.11
 b) 4.61 e) 0.27
 c) 1.0 f) 6.21

Solution

$$P_e = \int_A^{\infty} \frac{1}{2} e^{-|V_N|} dV_N = -\frac{1}{2} e^{-V_N} \Big|_A^{\infty} = \frac{1}{2} e^{-A}$$

For $P_e = 0.01 = \frac{1}{2} e^{-A}$, $A = -\ln(0.02) = 3.9$

(since this answer is not in the choices, this question is removed from the exam. It is my mistake/typo that the question was supposed to be for $P_e \leq 0.001$ not $P_e \leq 0.01$).

(see 19.6.2014 makeup exam above)

2. Determine the response $y(t)$ of the matched filter to the symbol waveform (A $0 < t < T_b$, 0 otherwise) when a matched filter $H(\omega)$ is used.

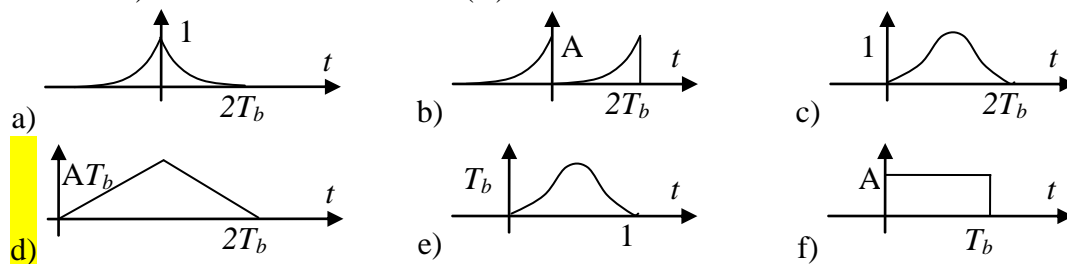

3. What is the probability of decision error P_e when the matched filter is used and $AT_b = 1$?

- a) $1/2e$ b) 0.1×10^{-3} c) $\ln(1/2)$ d) 0.052 e) 0.001 f) 0.0

4. Let A_2 and A_1 be the pulse amplitudes in cases with and without $H(\omega)$ respectively. What should be the ratio A_2/A_1 of the pulse amplitudes to have the same P_e in both cases?

- a) $A_2^2 T_b^2$ b) A_2^2 c) 1 d) $A_2 T_b$ e) $1/T_b$ f) A_2/T_b

Solution

$$P_e = \frac{1}{2} e^{-A_1} = \frac{1}{2} e^{-A_2 T_b} \text{ (see prev. question for the signal amplitude of the matched filter case).}$$

From here, $A_1 = A_2 T_b \Rightarrow A_2 / A_1 = 1/T_b$

5. What is the fundamental frequency of the following periodic signal?

| | | | |
|--|--------|---------------|--------|
| | a) 1/2 | b) 1/3 | c) 1/4 |
| | d) 4 | e) 1 | f) 3 |

6. What would be the logical choice of order for a cascaded amplifiers with noise figures of $F_1 = 5$, $F_2 = 2$, $F_3 = 1$ and available power gains of $H_{\max}^2 = 10$ (all same)?

- a) 2,3,1 b) 2,1,3 **c) 3,2,1** d) 1,3,2 e) 3,1,2 f) 1,2,3

7. What is the length of the m-sequence generated by the shift-register generator described by [9,6,4,3]?

- a) 22 **b) 511** c) 512 d) 31 e) 256 f) 255

8. What would the output noise power be when input noise is white with spectral density of $S_n=1$ W/Hz, $L=1$ H and $R=1\Omega$ in the following LTI filter?

| | | | |
|--|------------|---------|----------------|
| | a) $\pi/4$ | b) 1 | c) $\pi/2$ |
| | d) $N_0/2$ | e) 3.14 | f) 0.25 |

Solution

$$H(\omega) = \frac{R}{R + j\omega L}, \quad |H(\omega)|^2 = \frac{R^2}{R^2 + \omega^2 L^2} = \frac{1}{1 + \omega^2 \frac{L^2}{R^2}}$$

$$P_{no} = 2 \int_0^{\infty} S_n |H(\omega)|^2 df = 2 \int_0^{\infty} \frac{1}{1 + \omega^2 \frac{L^2}{R^2}} df \quad \text{and } \omega = 2\pi f$$

$$P_e = 2 \int_0^{\infty} \frac{1}{1 + 4\pi^2 f^2 \frac{L^2}{R^2}} df, \quad \text{and let } u = 2\pi \frac{L}{R} f, \quad du = 2\pi \frac{L}{R} df, \quad \Rightarrow \frac{R}{2\pi L} du = df$$

$$P_e = \frac{R}{\pi L} \int_{f=0}^{f=\infty} \frac{1}{1 + u^2} du = \frac{R}{\pi L} \text{atan}(u) \Big|_{f=0}^{f=\infty} = \frac{R}{2L}, \quad \text{and for } L=R=1, \quad P_e = \frac{1}{2}.$$

(This question is removed from the exam. It is my mistake to omit 2x while calculating the integral from 0 to $+\infty$ instead of $-\infty$ to $+\infty$)

9. Which of the following is not a reason for employing spread spectrum?

- a) Better spectral efficiency b) Better time resolution
 c) Security against unintended listeners d) Multiple access
 e) protection against interference f) Better noise immunity

10. What is the probability density function of the samples taken from the periodic saw-tooth waveform given?

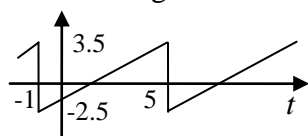

- a) b) c) d) e) f) **b)**



11. What is the modulation type of $y(t) = A_k \cos(\omega t + \phi_k)$ where $k \in 0, 1, \dots, M-1$?
- a) QPSK b) PSK c) ASK **d) QAM** e) APM f) QPM

12. A baseband signal is multiplied twice by a carrier and passed from a band-pass filter. One sided spectrum of the baseband signal, carrier and the filter passband are shown below. Assume that $\omega_1 = 2\omega_c - \omega_m$ and $\omega_2 = 2\omega_c + \omega_m$?

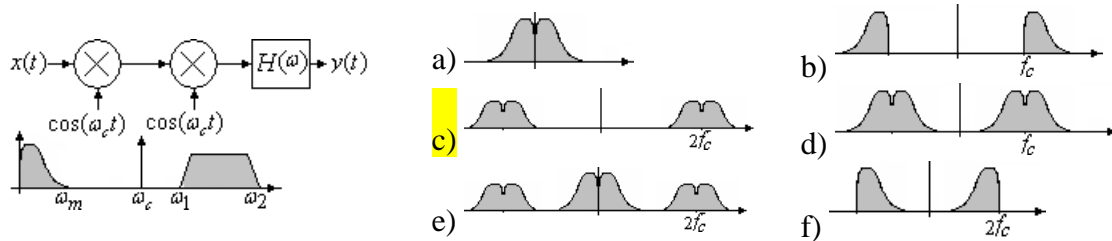

13. An information source whose ensemble is (A, z) where $A = \{a, b, c, d\}$ and $z = \{0.6, 0.3, 0.05, 0.05\}$ is given. What would be the average code length when the source output were Shannon-Fano coded?
- a) 1.81 b) 1.6 c) 1.8 d) 2.0 **e) 1.5** f) 1.57

14. The following one-sided spectrum is given for a signal centered at 20 MHz. What is the minimum sampling frequency within the following selections in order to reconstruct the signal?

| | | | |
|--|-----------|-----------------|-----------|
| | a) 20 kHz | b) 8 MHz | c) 4 MHz |
| | d) 5 MHz | e) 20 GHz | f) 44 MHz |

79. 5.04.2017 Midterm

1. The baseband signal $x(t) = \cos(20\pi t) + 2\sin(22\pi t)$ is applied to the following system. Draw the single sided magnitude spectrum of the output $y(t)$.

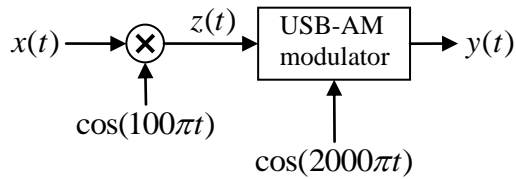

Solution:

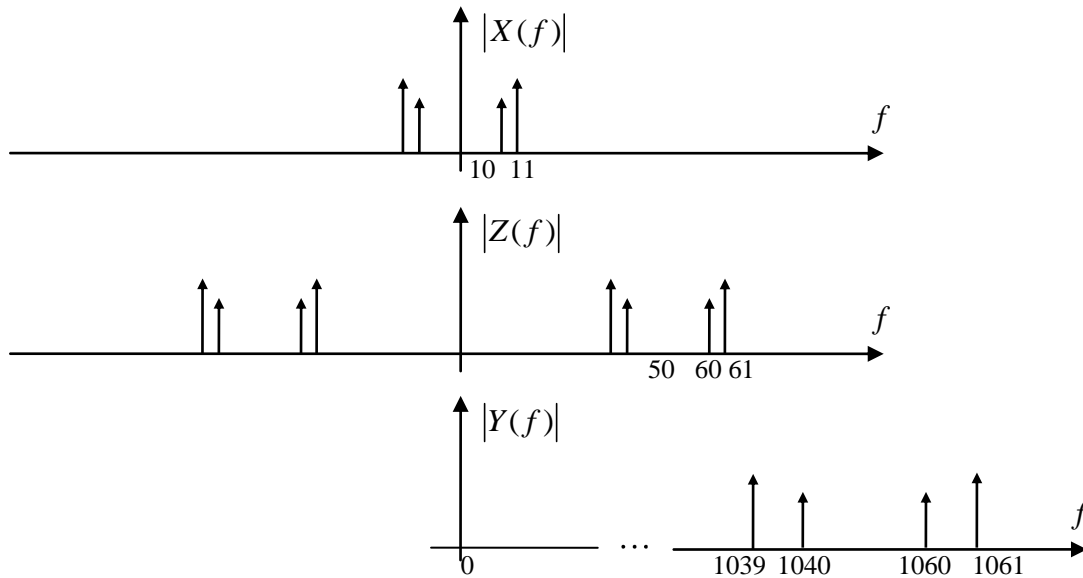

$Z(f)$ or its graph : 10p

Graph of $Y(f)$: 15p (or 25p if $Z(f)$ is not given)

Incorrect axes titles/units : -2p each. Unrelated freq. components : -5p each

2. For the constellation diagram given, what would be the I-Q modulator table entries to have unit amplitude (maximum) at the output?

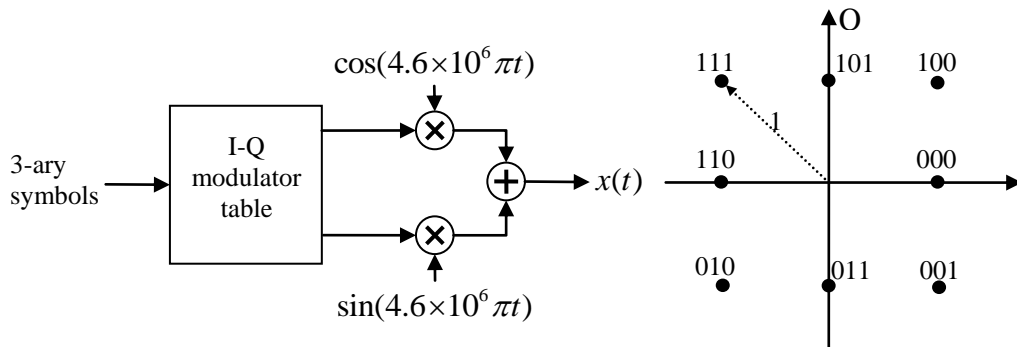

Solution:

Table of 8 rows : 10p

Correct values in table : +15p



| | I | Q |
|-----|--------|--------|
| 000 | 1.0 | 0.0 |
| 001 | 0.707 | -0.707 |
| 010 | -0.707 | -0.707 |
| 011 | 0.0 | -1.0 |
| 100 | 0.707 | 0.707 |
| 101 | 0.0 | 1.0 |
| 110 | -1.0 | 0.0 |
| 111 | -0.707 | 0.707 |

3. A binary transmission system uses the following waveform and its antipodal counterpart to represent binary 1 and 0 symbols respectively. On the receiver, a correlator receiver is used as shown. The correlator output signal at the fully synchronous measurement times is $y[nT_b] = R[nT_b] + \eta$. η is the noise component whose pdf is also given below.

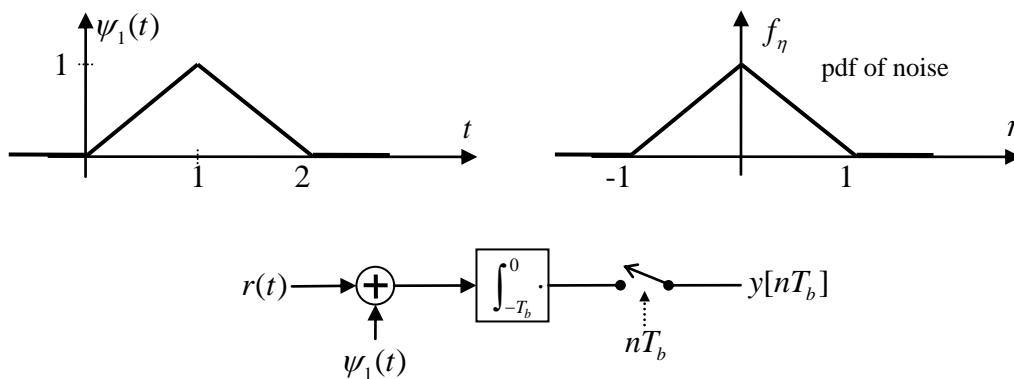

Calculate the probability of decision error p_e , assuming that the system is in full synchronization, symbol transmission probabilities are equal and the channel has no ISI (intersymbol interference).

Solution:

In full synchronization $R[nT_b] = \pm \int_0^{T_b} \psi_1^2(t) dt = \pm 2 \int_0^1 t^2 dt = \pm \frac{2t^3}{3} \Big|_0^1 = \pm \frac{2}{3}$. (15p)

At the decision instant, pdf's of the two output possibilities will be as shown

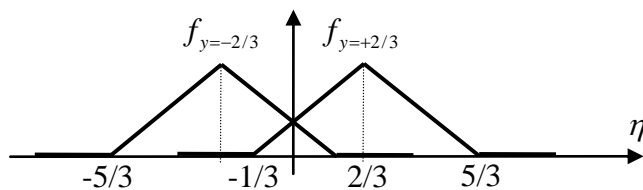

Assuming that the decision threshold is at 0, $p_e = \int_{-1/3}^0 u du = \frac{1}{2} u^2 \Big|_{-1/3}^0 = \frac{1}{18}$ (+10p)

4. Show that $\psi_n(t) = \cos(2\pi nt), n = 1, 2, \dots$ is an orthonormal waveform set ($\psi_i(t) \perp \psi_j(t), i \neq j$ and $E_{\psi_i} = 1$) for $0 < t < 1$.

Solution:

Two waveforms are orthogonal if $\langle \psi_i, \psi_j \rangle = \int_T \psi_i \psi_j^* dt = 0$. Applying this,

$$\begin{aligned} \langle \psi_i, \psi_j \rangle &= \int_0^1 \cos(2\pi nt) \cos(2\pi mt) dt = \frac{1}{2} \int_0^1 [\cos(2\pi(n-m)t) + \cos(2\pi(m+n)t)] dt \\ &= \frac{1}{2} \int_0^1 \cos(2\pi(n-m)t) dt + \frac{1}{2} \int_0^1 \cos(2\pi(m+n)t) dt \\ &= \frac{\sin(2\pi(n-m)t)}{4\pi(n-m)} \Big|_0^1 + \frac{\sin(2\pi(m+n)t)}{4\pi(m+n)} \Big|_0^1 = 0 + 0 \text{ for } n \neq m \text{ and both are integers. (15p)} \end{aligned}$$

Checking the energies of individual waveforms,

$$\begin{aligned} E_{\psi_i} &= \int_T |\psi_i|^2 dt = \int_0^1 \cos^2(2\pi nt) dt = \int_0^1 (\frac{1}{2} + \frac{1}{2} \cos(4\pi nt)) dt = \frac{1}{2} t + \frac{1}{8\pi n} \sin(4\pi nt) \Big|_0^1 \\ E_{\psi_i} &= \frac{1}{2}. \text{ (10p)} \end{aligned}$$

Therefore waveforms are orthogonal but have not unit energy. For that, waveforms should have been $\psi_n(t) = \sqrt{2} \cos(2\pi nt), n = 1, 2, \dots, 0 < t < 1$.

80. 12.03.2018 Quiz-1

A ternary source is given with $z = \{0.6, 0.3, 0.1\}$

- Determine the average information I_{avg} per source output
- Determine I_{avg} for the second extension of the source.

Solution

a) (50p) $I_{avg} = H(z) = -\sum_{i=0}^2 p_i \log_2(p_i) \approx 0.6 \times 0.737 + 0.3 \times 1.737 + 0.1 \times 3.322 = 1.2955$

b) (50p) $I_{avg_nth} = H(u) = nH(z)$

$$I_{avg_2nd} = H(u) = 2H(z) \approx 2 \times 1.2955 = 2.591 \text{ bits/symbol}$$

another solution for b) (50p)

$$u = \{0.6 \times 0.6, 0.6 \times 0.3, 0.6 \times 0.1, 0.3 \times 0.6, 0.3 \times 0.3, 0.3 \times 0.1, 0.1 \times 0.6, 0.1 \times 0.3, 0.1 \times 0.1\}$$

$$u = \{0.36, 0.18, 0.06, 0.18, 0.09, 0.03, 0.06, 0.03, 0.01\}$$

$$I_{avg_2nd} = H(u) = -\sum_{i=0}^8 p_i \log_2(p_i) \approx 2.591 \text{ bits/symbol}$$

81. 19.03.2018 Quiz-2

The signal $r(t) = \sin(2\pi f_1 t) + \cos(2\pi f_2 t + \frac{\pi}{2})$ is applied to the input of the following system



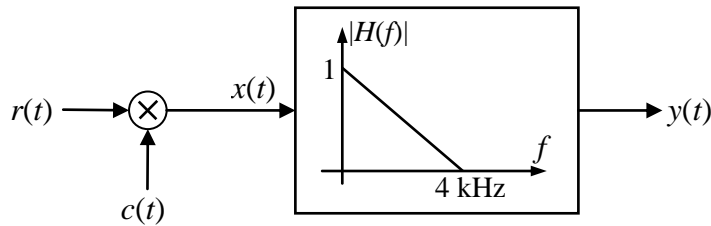

where $c(t) = 2\sin(2\pi f_1 t)$. Given that $f_1 = 100$ kHz and $f_2 = 102$ kHz, draw output magnitude spectrum $|Y(f)|$.

Solution

Applying modulation property of Fourier transform on the input signal, we get the following magnitude spectrum for $x(t)$ (filter input). (50p)

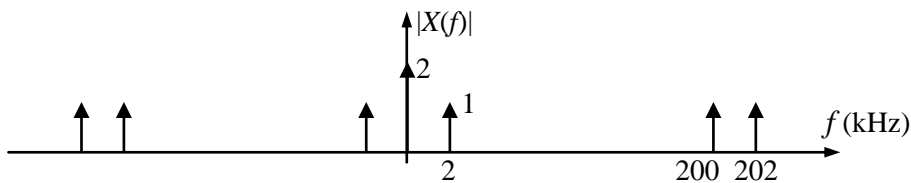

Applying filter gains of 1 and 0.5 at frequencies 0 and 2 kHz respectively, $|Y(f)|$ will be as shown below (50p).

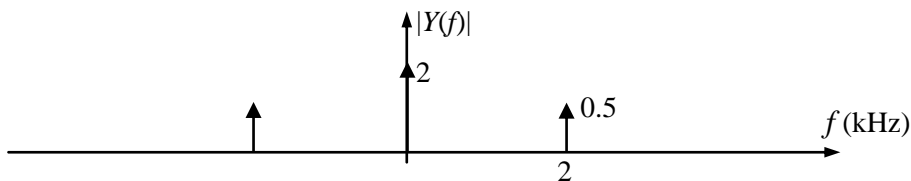

note : Calculation of $x(t)$ using trigonometric identities, and $|X(f)|$ afterwards, will get the same 50p in the first step.

82. 07.05.2018 Quiz-3

A 1 Mbps binary stream will be transmitted using M-PSK with 10 MHz carrier. The maximum allowed null-to-null bandwidth is 1 MHz. The maximum allowed transmitter output peak-to-peak voltage is 10 Vpp.

- Draw power spectrum of the resulting signal (at transmitter) with all symbols/markings/units on it.
- Draw the constellation diagram with minimum number of possible symbols (stars) and minimum error rate. Put all clarifying symbols/markings/units on it.

Solution

- Since it is M-PSK, the spectrum will be a *squared sinc* centered at 10 MHz and nulls of main lobe at 9.5 MHz and 10.5 MHz, having max allowed null-to-null bw of 1 MHz. (50p)

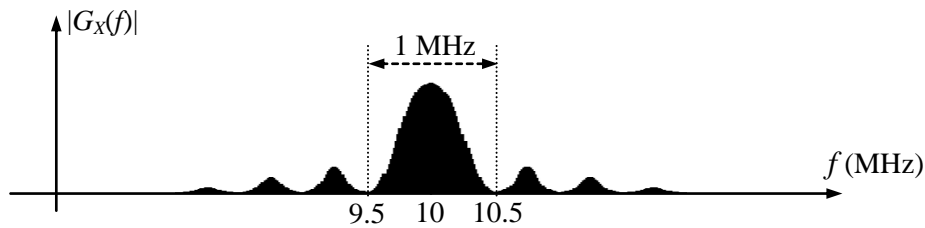

- b) Spectrum hints a 500 kbps symbol rate. Since we are required to transmit 1 Mbps, each symbol will carry 2 bits, resulting in $2^2=4$ symbols. This will be a 4-PSK. Any phase angles would do, but since min error rate is required it should be a QPSK where distances between waveforms are maximized. The max peak-to-peak transmitter output voltage requirement leads us to place waveform marks on 5 V distances from the center. Two example constellations are shown below. (50p)

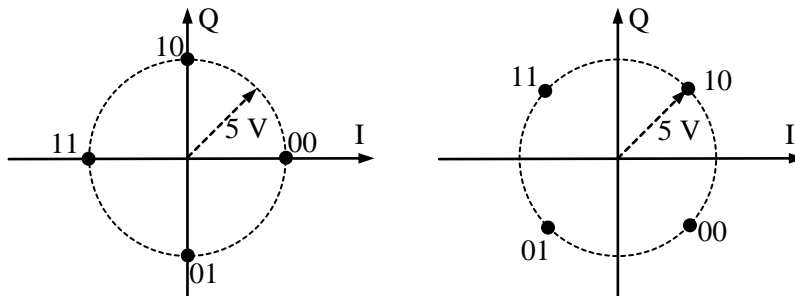

83. 03.04.2018 Midterm

1. A signal with 20 MHz null-to-null bandwidth and total power of 1 W covers the spectrum as shown in the one-sided power spectral density graph below. Find G_m .

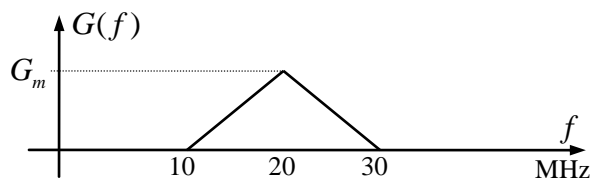

Solution:

$$P = \int_{10 \times 10^6}^{30 \times 10^6} G(f) df = 2 \int_0^{10 \times 10^6} \frac{G_m}{10 \times 10^6} f df = \frac{G_m}{10 \times 10^6} f^2 \Big|_0^{10 \times 10^6} = \frac{G_m}{10 \times 10^6} 100 \times 10^{12}$$

$$P = 10 \times 10^6 G_m = 1 [W]. \quad G_m = 1.0 \times 10^{-7} [W / Hz] = 0.1 [\mu W / Hz]$$

2. The following single-sided magnitude spectrum is given for a DSB signal (shown as input to a system). Draw the block diagram of the system that moves the center of signal spectrum to $f = 200 \text{ kHz}$ (with some carrier) as shown at the output. You may use adders, multipliers and filters with critical frequencies shown.

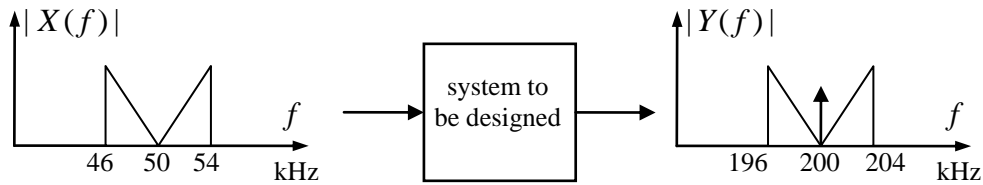

Solution:

Among the several solutions, two are easily recalled;

1. Move it to baseband first, add DC and use it to modulate 200 kHz carrier.
2. Directly move it to 200 kHz using a 200-50=150 kHz carrier, adding desired amount of 50 kHz carrier before or adding 200 kHz carrier after this operation.

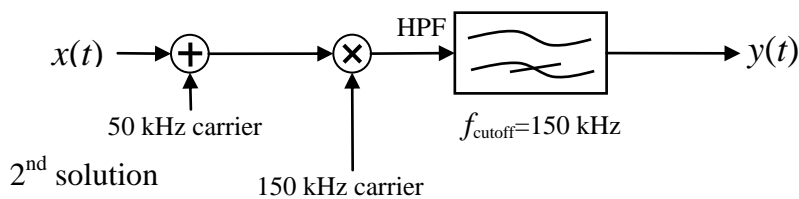

note that 150kHz added carrier does not make the signal demodulated by an envelope detector since it may not be in phase with the actual DSB-SC-AM signal carrier.

3. A lossless entropy encoder calculates the input statistics and generates the symbol table $S=\{0,10,110,111\}$. Create an example finite length symbol stream composed of $A=\{a,b,c,d\}$ that makes L_{avg} as close to H as possible.

Solution:

We have no way of calculating actual statistics from the code-table, but we know that for $L_{avg} = H$ code lengths must be equal to self-information of symbols. For that,

$I_i = L_i = \{1,2,3,3\}$. That is, $I_a = -\log_2 P_a = 1$, $I_b = -\log_2 P_b = 2$, $I_c = -\log_2 P_c = 3$ and $I_d = -\log_2 P_d = 3$. From these, we find that $P_a = 0.5$, $P_b = 0.25$ and $P_c = P_d = 0.125$. That is 50% of the symbols in the stream are a s, 25% are b s and c and d s cover 12.5% each. Consequently, for each d in the stream, we should have 1 c , 2 b s and 4 a s. Shortest stream that satisfies this would be stream = "dcbbaaaa". The order of symbols does not matter, so "abcdabaa" would also satisfy statistics criteria as several others also do.

4. The following $\psi_i(t)$ orthonormal waveform set and $y(t) = \sum_i c_i \psi_i(t)$ are given.

Determine the coefficients c_i using correlation/inner-product.

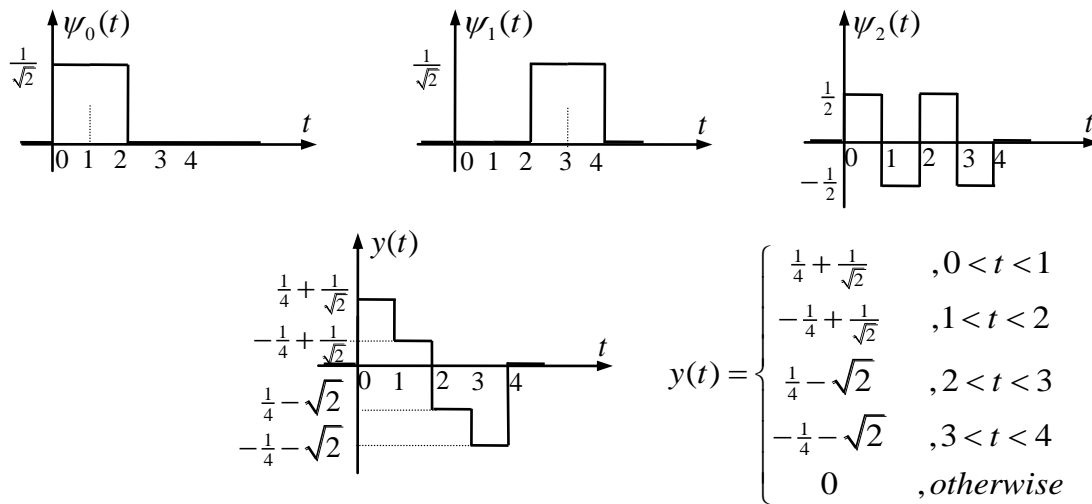

Solution:

c_i s are contributions of $\psi_i(t)$ s to $y(t)$ and can be found by $c_i = \int_{-\infty}^{\infty} y(t)\psi_i(t)dt$ correlation/inner-product answering the question "how much of $\psi_i(t)$ is in $y(t)$?".

$$c_0 = \int_0^4 y(t)\psi_0(t)dt = \int_0^1 (\frac{1}{4} + \frac{1}{\sqrt{2}}) \frac{1}{\sqrt{2}} dt + \int_1^2 (-\frac{1}{4} + \frac{1}{\sqrt{2}}) \frac{1}{\sqrt{2}} dt = 1$$

$$c_1 = \int_0^4 y(t)\psi_1(t)dt = \int_2^3 (\frac{1}{4} - \sqrt{2}) \frac{1}{\sqrt{2}} dt + \int_3^4 (-\frac{1}{4} - \sqrt{2}) \frac{1}{\sqrt{2}} dt = -2$$

$$c_2 = \int_0^4 y(t)\psi_2(t)dt = \int_0^1 (\frac{1}{4} + \frac{1}{\sqrt{2}}) \frac{1}{2} dt + \int_1^2 (\frac{1}{4} - \frac{1}{\sqrt{2}}) \frac{1}{2} dt + \int_2^3 (\frac{1}{4} - \sqrt{2}) \frac{1}{2} dt - \int_3^4 (-\frac{1}{4} - \sqrt{2}) \frac{1}{2} dt$$

$$c_2 = 0.5$$

So that, $y(t) = \sum_{i=0}^2 c_i \psi_i(t) = \psi_0(t) - 2\psi_1(t) + 0.5\psi_2(t)$

84. 29.05.2018 Final Exam

1. A 4-ary source is given with $z=\{0.5, 0.25, 0.125, 0.125\}$
- c) Determine the average information I_{avg} per source output
- d) Determine I_{avg} for the second extension of the source.

Solution

c) (10p) $I_{avg} = H(z) = -\sum_{i=0}^3 p_i \log_2(p_i) = 0.5 \times 1 + 0.25 \times 2 + 0.125 \times 3 \times 2 = 1.75$

d) (10p) $I_{avg_nth} = H(u) = nH(z)$

$$I_{avg_2nd} = H(u) = 2H(z) \approx 2 \times 1.75 = 3.5 \text{ bits/symbol}$$

2. The signal $r(t) = \sin(2\pi f_1 t) + \cos(2\pi f_2 t + \frac{\pi}{2})$ is applied to the input of the following system where $c(t) = 2 \sin(2\pi f_1 t)$.



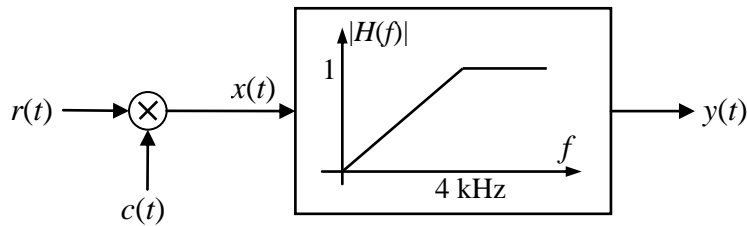

Given that $f_1=100$ kHz and $f_2=102$ kHz, draw output magnitude spectrum $|Y(f)|$.

Solution

Applying modulation property of Fourier transform on the input signal, we get the following magnitude spectrum for $x(t)$ (filter input).

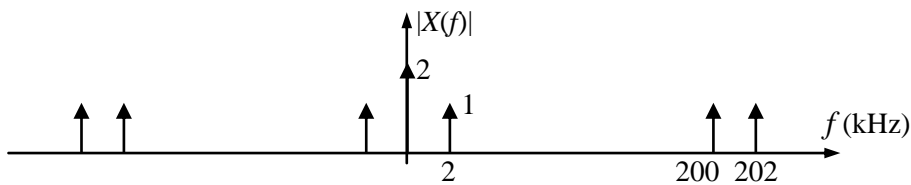

Applying filter gains of 0, 0.5 and 1.0 at frequencies 0, 2 and $f>4$ kHz respectively, $|Y(f)|$ will be as shown below.

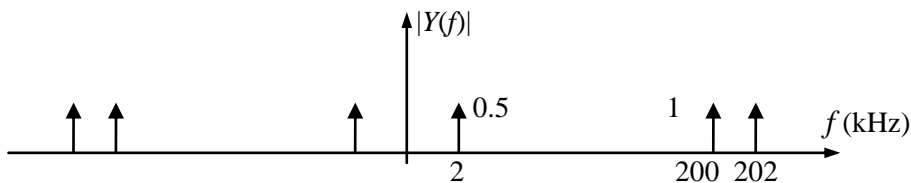

(each component pair at correct frequencies:5p, correct amplitudes:5p)

3. A random stream of 4-bit words (nibbles) is to be transmitted using QPSK and BPSK modulators with carriers 0.1 MHz apart as shown in the figure.

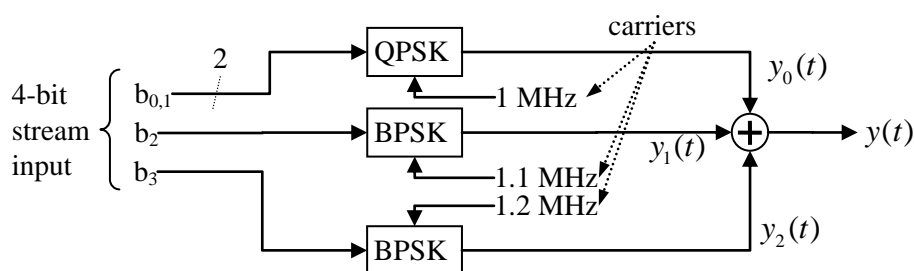

What should be the bit rate for $y_i(t)$ to be orthogonal? What is the null-to-null bandwidth of the total signal $y(t)$ in that case?

Solution

Since the carriers are 0.1 MHz apart, the symbol rate should be 0.1 Msps, hence the bit rate is 400 kbps.

The null-to-null bw of $y(t)$ will then be 400 kHz as illustrated in the figure below.

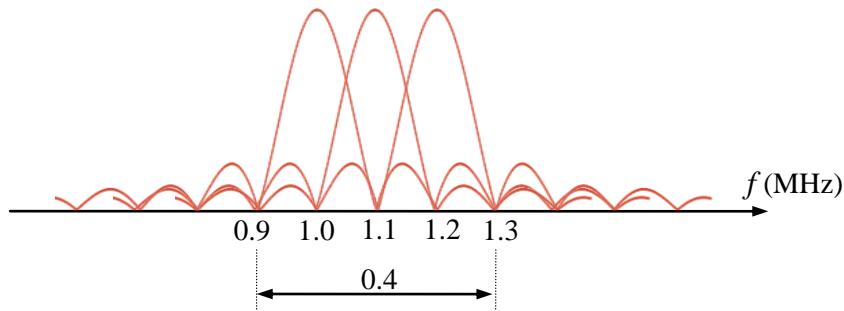

Note that the orthogonality can also be obtained by having sinc nulls at $0.1/n$ around the center frequencies, where n is an integer. This obviously reduces the bitrate. Halving the symbol rates for each channel is an example.

(bit rate:10p, bw:10p)

4. Find out the m-sequence generated by SSRG[4,1] by drawing the generator first.

Solution

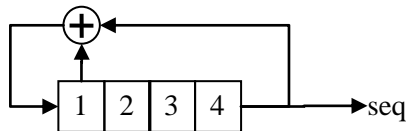

1000 initial value
 1100
 1110
 1111
 0111
 1011
 0101
 1010
 1101
 0110
 0011
 1001
 0100
 0010
 0001

The sequence is 000111101011001.

(circuit:10p, sequence:10p, rotated versions are ok too)

5. A communication system with the following constellation diagram has $BER=10^{-3}$ under AWGN. We wish to use an output amplifier at the transmitter in order to improve performance to $BER=10^{-5}$. What should be the amplifier power gain?

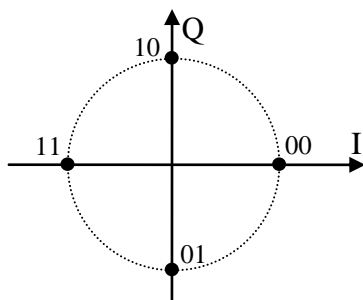

Solution

$$p_e = Q(\sqrt{2SNR})$$

$$10^{-3} = Q(\sqrt{2SNR_1}) \text{ and } 10^{-5} = Q(\sqrt{2SNR_2}).$$

$$\sqrt{2SNR_1} \cong 3.1, \sqrt{2SNR_2} \cong 4.25 \text{ (found approximately from tables)}$$

$$SNR_1 = 4.805, SNR_2 = 9.03$$

$$\frac{SNR_2}{SNR_1} = 1.88. \text{ (20p)}$$

Assuming that the noise stays the same, this number is the power gain necessary to achieve $BER=10^{-5}$.